

Contents

Model DLFU	100DLFU61.5	100DLFU637	250DLFU611
	100DLFU62.2	100DLFU645	250DLBFU615
50DLFU61.5	100DLMFU62.2	150DLFU67.5	250DLCFU615
80DLFU61.5	100DLFU63.7	150DLFU611	250DLFU618
80DLMFU61.5	100DLMFU63.7	150DLFU615	250DLFU622
80DLFU62.2	100DLFU65.5	150DLFU618	250DLFU630
80DLMFU62.2	100DLMFU65.5	150DLFU622	250DLFU637
80DLFU63.7	100DLFU67.5	150DLFU630	250DLFU645
80DLMFU63.7	100DLMFU67.5	150DLFU637	300DLFU618
80DLFU65.5	100DLFU611	150DLFU645	300DLFU622
80DLMFU65.5	100DLMFU611	200DLFU67.5	300DLFU630
80DLFU67.5	100DLFU615	200DLFU611	300DLFU637
80DLCMFU67.5	100DLMFU615	200DLFU615	300DLFU645
80DLFU611	100DLFU618	200DLFU618	
80DLCMFU611	100DLMFU618	200DLFU622	
80DLFU615	100DLFU622	200DLFU630	
80DLFU618	100DLMFU622	200DLFU637	
80DLFU622	100DLFU630	200DLFU645	

Section	Page
Specifications	2-158
Selection Chart	2-165
Performance Curves	2-166
Outline Drawings	2-191
Sectional View	2-210
QDC Information	2-278
Technical Information	2-289.1
material specification	
impeller description	
motor protection	
cable entry	
paint specifications	
mechanical seal	
general	
Motor Data	2-315.1
motor electrical specifications	
cable data	
wiring diagrams	
motor electrical data	



Model Designation

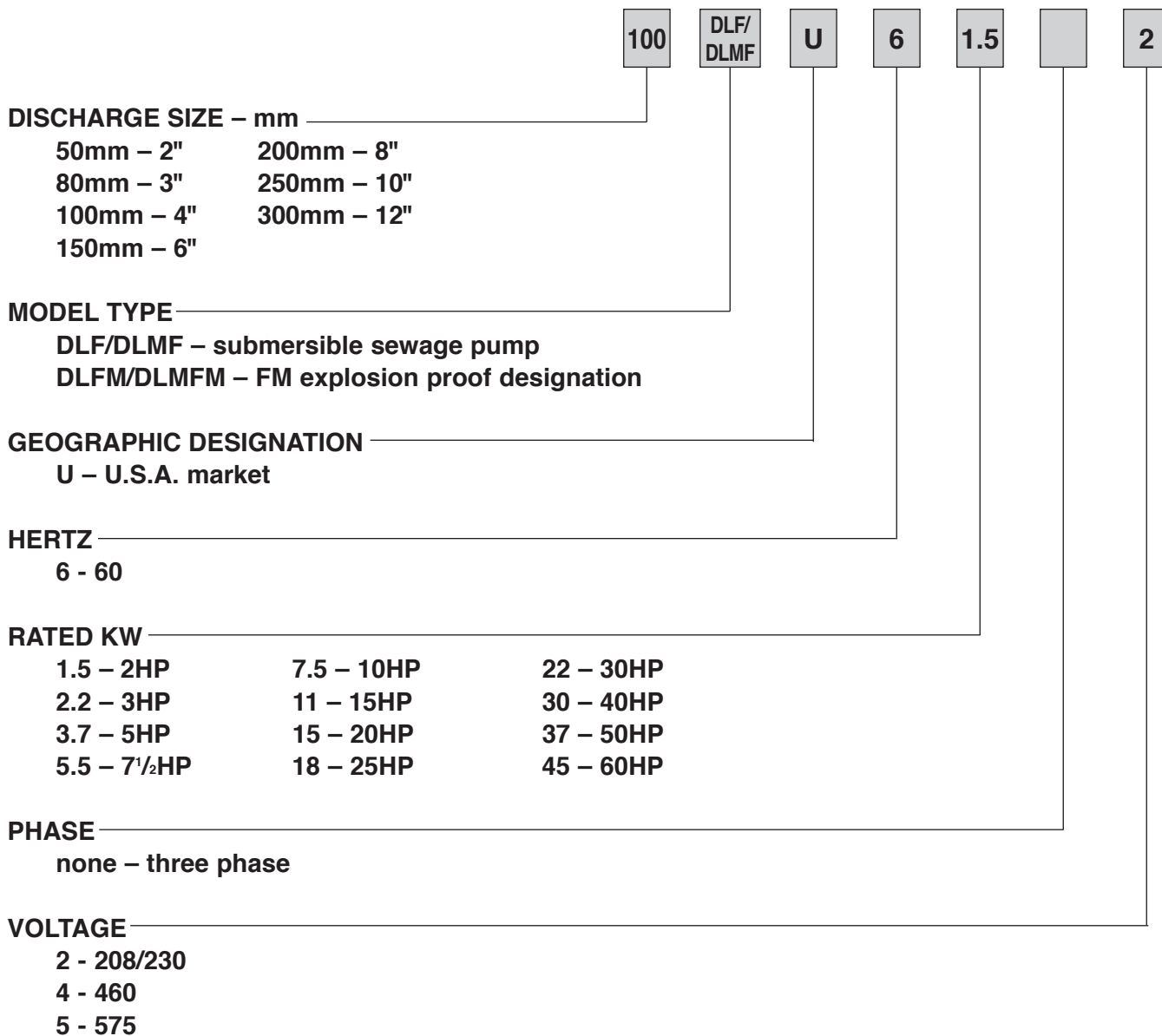

Specifications

Model DLFU
Specifications

	Standard	Optional
Size	2, 3, 4, 6, 8, 10, 12 inch	
Range of HP	2 to 60 HP	
Range of Performance	Capacity 13 to 4000 GPM Head 7 to 243 feet	
Limitation Maximum Water Temperature	104°F (40°C)	
Synchronous Speed	1800 RPM	
Materials Casing Impeller Shaft Motor Frame Fastener	Cast Iron Cast Iron (2 to 60HP) Ductile Iron (150-300 DLFU 40 to 60 HP) 403 Stainless Steel (2 to 5HP) 420 Stainless Steel (7½ to 60HP) Cast Iron 304 Stainless Steel	
Mechanical Seal Material – Upper Side Material – Lower Side Impeller Type Bearing Motor Three Phase Service Factor Motor Protection Submersible cable	Double Mechanical Seal Carbon/Ceramic (2 to 60HP) Silicon Carbide/Silicon Carbide (2 to 60HP) Tungsten Carbide/Tungsten Carbide (150-300 DLFU 50 and 60HP only) Semi-open (2 to 30HP) Enclosed (40 to 60HP) Prelubricated Ball Bearing Insulation Class H 208/230/460V 1.15 Thermal Detector – Klixons Mechanical Seal Leakage Detector – Float Switch 33 ft. (2 to 5HP) 40 ft. (7½ to 60HP)	Tungsten Carbide/Tungsten Carbide Tungsten Carbide/Tungsten Carbide FM Explosion Proof, Class 1, Division 1, Group C, D ____ ft. (customer specified)
Accessories		QDC System

Specifications

A. General:

Provide submersible sewage pumps suitable for continuous duty operation underwater without loss of watertight integrity to a depth of 65 feet. Pump system design shall include a guide rail system be such that the pump will be automatically connected to the discharge piping when lowered into place on the discharge connection. The pump shall be easily removable for inspection or service, requiring no bolts, nuts, or other fasteners to be disconnected, or the need for personnel to enter the wet well. The motor and pump shall be designed, manufactured, and assembled by the same manufacturer.

B. Manufacturer:

EBARA International Corporation

C. Pump Characteristics:

Pumps shall conform to the following requirements:

Number of units	
Design flow (gpm)	
Design TDH (ft)	
Minimum shut off head (ft)	
RPM	1800
Maximum HP	
Minimum efficiency at design (%)	
Minimum power factor at design (%)	
Voltage/HZ	208/230V, 460V / 60
Phase	3

D. Pump Construction:

All major parts of the pumping unit(s) including casing, impeller, suction cover, wear rings, motor frame and discharge elbow shall be manufactured from gray cast iron, ASTM A-48 Class 30. Castings shall have smooth surfaces devoid of blow holes or other casting irregularities. Casing design shall be centerline discharge with a large radius on the cut water to prevent clogging. Units shall be furnished with a discharge elbow and 125 lb. flat face ANSI flange. All exposed bolts and nuts shall be 304 stainless steel. All mating surfaces of major components shall be machined and fitted with NBR O-rings where watertight sealing is required. Machining and fitting shall be such that sealing is accomplished by automatic compression of O-rings in two planes and O-ring contact is made on four surfaces without the requirement of specific torque limits. Internal and external surfaces are prepared to SPPC-VISI-SP-3-63 then coated with a zinc-chromate primer. The external surfaces are then coated with a H.B. Teneme-Tar 46H-413 Polyamide Epoxy - Coal Tar paint

1. Impellers:

- a. For units 2 to 5 HP, the impeller shall be radial single or multi-vane, semi-open design. It shall be dynamically balanced and shall be designed for solids handling with a long thrulet without acute turns. The inlet edge of the impeller vanes shall be angled toward the impeller periphery so as to facilitate the release of objects that might otherwise clog the pump. The 2 to 5 HP impeller design shall also include back pump out vanes to reduce the pressure and entry of foreign materials into the mechanical seal area. In addition, a lip seal shall be located behind the impeller hub to further reduce the entry of foreign materials into the seal area. Impellers shall be direct connected to the motor shaft with a slip fit, key driven, and secured with an impeller bolt. The design shall include a replaceable cast iron suction cover. The suction cover shall be designed such that it may be adjusted to maintain working clearances and hydraulic efficiencies.
- b. For units 7½ to 30 HP, the impeller shall be a mixed flow multi-vane semi-open design. It shall be dynamically balanced and shall be designed for solids handling with a long thrulet without acute turns. The inlet edge of the impeller vanes shall be angled toward the impeller periphery so as to facilitate the release of objects that might otherwise clog the pump. The 7½ to 30 HP impeller design shall also include back pump out vanes to reduce the pressure and entry of foreign materials into the mechanical seal area. In addition, a lip seal shall be located behind the impeller hub to further reduce the entry of foreign materials into the seal area. Impellers shall be direct



Specifications

connected to the motor shaft with a slip fit, key driven, and secured with an impeller bolt. The design shall include a replaceable cast iron suction cover. The suction cover shall be designed such that it may be adjusted to maintain working clearances and hydraulic efficiencies.

- c. For high head units with 4" discharge, 40 to 60 HP shall have a radial multi-vane, enclosed impeller design. It shall be dynamically balanced and shall be designed for solids handling with a long thrulet without acute turns. The inlet edge of the impeller vanes shall be angled toward the impeller periphery so as to facilitate the release of objects that might otherwise clog the pump. A lip seal shall be located behind the impeller hub to reduce the entry of foreign materials into the mechanical seal area. Impellers shall be direct connected to the motor shaft with a slip fit, key driven, and secured with an impeller bolt. The design shall include a replaceable casing wear ring at the pump suction to maintain working clearances and hydraulic efficiencies.
- d. For units 6" to 12" discharge sizes, 40 to 60 HP, the impeller shall be a mixed flow multi-vane enclosed design. It shall be dynamically balanced and shall be designed for solids handling with a long thrulet without acute turns. The inlet edge of the impeller vanes shall be angled toward the impeller periphery so as to facilitate the release of objects that might otherwise clog the pump. A lip seal shall be located behind the impeller hub to reduce the entry of foreign materials into the seal area. Impellers shall be direct connected to the motor shaft with a slip fit, key driven, and secured with an impeller bolt. The design shall include a replaceable casing wear ring at the pump suction to maintain working clearances and hydraulic efficiencies.

Optional K-series design:

- e. For units 2 to 5 HP, the impeller shall be radial single or multi-vane, semi-open design. It shall be dynamically balanced and shall be designed for solids handling with a long thrulet without acute turns. The inlet edge of the impeller vanes shall be angled toward the impeller periphery so as to facilitate the release of objects that might otherwise clog the pump. The 2 to 5 HP impeller design shall also include back pump out vanes to reduce the pressure and entry of foreign materials into the mechanical seal area. In addition, a lip seal shall be located behind the impeller hub to further reduce the entry of foreign materials into the seal area. Impellers shall be direct connected to the motor shaft with a slip fit, key driven, and secured with an impeller bolt. The design shall include a replaceable cast iron suction cover. The suction cover shall contain a groove(s) perpendicular to the suction opening to disrupt fibrous solids that may otherwise become lodged between the impeller and suction cover. The suction cover shall be designed such that it may be adjusted to maintain working clearances and hydraulic efficiencies.
- f. For units 7½ to 30 HP, the impeller shall be a mixed flow multi-vane semi-open design. It shall be dynamically balanced and shall be designed for solids handling with a long thrulet without acute turns. The inlet edge of the impeller vanes shall be angled toward the impeller periphery so as to facilitate the release of objects that might otherwise clog the pump. The 7½ to 30 HP impeller design shall also include back pump out vanes to reduce the pressure and entry of foreign materials into the mechanical seal area. In addition, a lip seal shall be located behind the impeller hub to further reduce the entry of foreign materials into the seal area. Impellers shall be direct connected to the motor shaft with a slip fit, key driven, and secured with an impeller bolt. The design shall include a replaceable cast iron suction cover. The suction cover shall contain a groove(s) perpendicular to the suction opening to disrupt fibrous solids that may otherwise become lodged between the impeller and suction cover. The suction cover shall be designed such that it may be adjusted to maintain working clearances and hydraulic efficiencies.

2. Mechanical Seals

- a. For units 2 to 5 HP, double mechanical seals operating in an oil bath shall be provided on all units. The oil filled seal chamber shall be designed to prevent over-filling and include an anti-vortexing vane to insure proper lubrication of both seal faces. Lower face materials shall be silicon carbide, upper faces carbon vs. ceramic, NBR elastomers, and 304SS hardware. Seal system shall not rely on pumping medium for lubrication.
- b. Units 7½ to 60 HP shall be designed to include a double mechanical seal in a tandem arrangement. Each seal shall be positively driven and act independently with its own spring system. The upper seal operates in an oil bath, while the lower seal is lubricated by the oil from between the shaft and the seal faces, and in contact with



Specifications

the pumpage. The oil filled seal chamber shall be designed to prevent over-filling and include an anti-vortexing vane to insure proper lubrication of both seal faces. Lower face materials shall be silicon carbide (tungsten carbide for 150-300 DLF 50 & 60 HP only), upper faces carbon vs. ceramic, NBR elastomers, and 304SS hardware. Seal system shall not rely on pumping medium for lubrication.

E. Motor Construction:

The pump motor shall be an air filled induction type with a squirrel cage rotor, shell type design, built to NEMA MG-1, Design B specifications. Stator windings shall be copper, insulated with moisture resistant Class H insulation, rated for 356°F. The stator shall be dipped and baked three times in Class H varnish and heat shrunk fitted into the stator housing. Rotor bars and short circuit rings shall be manufactured of cast aluminum. Motor shaft shall be one piece AISI403 for 2 to 5 HP, AISI420 for 7½ to 60 HP, rotating on two permanently lubricated ball bearings designed for a minimum B-10 life of 60,000 hours. Motor service factor shall be 1.15 and capable of up to 20 starts per hour. The motor shall be designed for continuous duty pumping at a maximum sump temperature of 104°F. Voltage and frequency tolerances shall be a maximum 10 / 5% respectively. Motor over temperature protection shall be provided by miniature thermal protectors embedded in the windings. Mechanical seal failure protection shall be provided by a mechanical float switch located in a chamber above the seal. This switch shall be comprised of a magnetic float that actuates a dry reed switch encapsulated within the stem. Should the mechanical seal fail, liquid shall be directed into the float chamber, in which the rising liquid activates the switch opening the normally closed circuit. For units 2 to 30 HP the float body and float shall be a polypropylene material with a 316SS stopper. Units 40 HP and greater, the float switch components shall be 304SS. The motor shall be non-overloading over the entire specified range of operation and be able to operate at full load intermittently while unsubmerged without damage to the unit.

Power cable jacket shall be manufactured of an oil resistant chloroprene rubber material, designed for submerged applications. Cable shall be watertight to a depth of a least 65'. The cable entry system shall comprise of primary, secondary, and tertiary sealing methods. The primary seal shall be achieved by a cylindrical elastomeric grommet compressed between the motor cover and a 304SS washer. Secondary sealing is accomplished with a compressed O-ring made of NBR material. Compression and subsequent sealing shall preclude specific torque requirements. The system shall also include tertiary sealing to prevent leakage into the motor housing due to capillary action through the insulation if the cable is damaged or cut. The cable wires shall be cut, stripped, re-connected with a copper butt end connector, and embedded in epoxy within the cable gland. This provides a dead end for leakage through the cable insulation into the motor junction area. The cable entry system shall be the same for both the power and control cables.

F. Guide Rail system:

Design shall include two (2) 304SS schedule 40 guide rails sized to mount directly to the quick discharge connector, QDC, at the floor of the wetwell and to a guide rail bracket at the top of the wetwell below the hatch opening, (refer to project drawings). Intermediate guide brackets are recommended for rail lengths over 15 feet.

Guide rails are not part of the pump package and shall be supplied by others.

The QDC shall be manufactured of cast iron, ASTM A48 Class 30. It shall be designed to adequately support the guide rails, discharge piping, and pumping unit under both static and dynamic loading conditions with support legs that are suitable for anchoring it to the wetwell floor. The face of the inlet QDC flange shall be perpendicular to the floor of the wetwell. The discharge flange of the QDC shall conform to ANSI B16.1 Class 125.

The pump design shall include an integral self-aligning sliding bracket. Sealing of the pumping unit to the QDC shall be accomplished by a single, linear, downward motion of the pump. The entire weight of the pump unit shall be guided to and wedged tightly against the inlet flange of the QDC, making metal to metal contact with the pump discharge forming a seal without the use of bolts, gaskets or O-rings.

A stainless steel lifting chain of adequate length for removing and installing the pump unit is recommended. The chain shall have a round link with a 2-¼" inside diameter every two feet. This link will allow for a sliding pinch bar through the link to pick the chain, more than once if necessary, at multiple intervals during pump removal and installation.



Specifications

A. General:

Provide FM explosion proof submersible non clog sewage pumps suitable for continuous duty operation underwater without loss of watertight integrity to a depth of 65 feet. Pump system design shall include a guide rail system be such that the pump will be automatically connected to the discharge piping when lowered into place on the discharge connection. The pump shall be easily removable for inspection or service, requiring no bolts, nuts, or other fasteners to be disconnected, or the need for personnel to enter the wet well. The motor and pump shall be designed, manufactured, and assembled by the same manufacturer.

B. Manufacturer:

EBARA International Corporation

C. Pump Characteristics:

Pumps shall conform to the following requirements:

Number of units	
Design flow (gpm)	
Design TDH (ft)	
Minimum shut off head (ft)	
RPM	1800
Maximum HP	
Minimum efficiency at design (%)	
Minimum power factor at design (%)	
Voltage/HZ	208/230V, 460V / 60
Phase	3

D. Pump Construction:

All major parts of the pumping unit(s) including casing, impeller, suction cover, wear rings, motor frame and discharge elbow shall be manufactured from gray cast iron, ASTM A-48 Class 30. Castings shall have smooth surfaces devoid of blow holes or other casting irregularities. Casing design shall be centerline discharge with a large radius on the cut water to prevent clogging. Units shall be furnished with a discharge elbow and 125 lb. flat face ANSI flange. All exposed bolts and nuts shall be 304 stainless steel. All mating surfaces of major components shall be machined and fitted with NBR O-rings where watertight sealing is required. Machining and fitting shall be such that sealing is accomplished by automatic compression of O-rings in two planes and O-ring contact is made on four surfaces without the requirement of specific torque limits. Internal and external surfaces are prepared to SPPC-VISI-SP-3-63 then coated with a zinc-chromate primer. The external surfaces are then coated with a H.B. Teneme-Tar 46H-413 Polyamide Epoxy - Coal Tar paint.

1. Impellers:

- a. For units 2 to 5HP, the impeller shall be single or radial multi-vane, semi-open design. It shall be dynamically balanced and shall be designed for solids handling with a long thrulet without acute turns. The inlet edge of the impeller vanes shall be angled toward the impeller periphery so as to facilitate the release of objects that might otherwise clog the pump. The 2 to 5 HP impeller design shall also include back pump out vanes to reduce the pressure and entry of foreign materials into the mechanical seal area. In addition, a lip seal shall be located behind the impeller hub to further reduce the entry of foreign materials into the seal area. Impellers shall be direct connected to the motor shaft with a slip fit, key driven, and secured with an impeller bolt. The design shall include a replaceable cast iron suction cover. The suction cover shall be designed such that it may be adjusted to maintain working clearances and hydraulic efficiencies.
- b. For units 7½ to 30 HP, the impeller shall be a mixed flow multi-vane semi-open design. It shall be dynamically balanced and shall be designed for solids handling with a long thrulet without acute turns. The inlet edge of the impeller vanes shall be angled toward the impeller periphery so as to facilitate the release of objects that might otherwise clog the pump. The 7½ to 30 HP impeller design shall also include back pump out vanes to reduce the pressure and entry of foreign materials into the mechanical seal area. In addition, a lip seal shall be located behind the impeller hub to further reduce the entry of foreign materials into the seal area. Impellers shall be direct



Specifications

connected to the motor shaft with a slip fit, key driven, and secured with an impeller bolt. The design shall include a replaceable cast iron suction cover. The suction cover shall be designed such that it may be adjusted to maintain working clearances and hydraulic efficiencies.

- c. For high head units, 4" discharge, 40 to 60 HP shall have a radial multi-vane, enclosed impeller design. It shall be dynamically balanced and shall be designed for solids handling with a long throulet without acute turns. The inlet edge of the impeller vanes shall be angled toward the impeller periphery so as to facilitate the release of objects that might otherwise clog the pump. A lip seal shall be located behind the impeller hub to reduce the entry of foreign materials into the mechanical seal area. Impellers shall be direct connected to the motor shaft with a slip fit, key driven, and secured with an impeller bolt. The design shall include a replaceable casing wear ring at the pump suction to maintain working clearances and hydraulic efficiencies.
- d. For units 6" to 12" discharge sizes, 40 to 60 HP, the impeller shall be a mixed flow multi-vane enclosed design. It shall be dynamically balanced and shall be designed for solids handling with a long throulet without acute turns. The inlet edge of the impeller vanes shall be angled toward the impeller periphery so as to facilitate the release of objects that might otherwise clog the pump. A lip seal shall be located behind the impeller hub to reduce the entry of foreign materials into the seal area. Impellers shall be direct connected to the motor shaft with a slip fit, key driven, and secured with an impeller bolt. The design shall include a replaceable casing wear ring at the pump suction to maintain working clearances and hydraulic efficiencies.

Optional K-series design:

- e. For units 2 to 5HP, the impeller shall be single or radial multi-vane, semi-open design. It shall be dynamically balanced and shall be designed for solids handling with a long throulet without acute turns. The inlet edge of the impeller vanes shall be angled toward the impeller periphery so as to facilitate the release of objects that might otherwise clog the pump. The 2 to 5 HP impeller design shall also include back pump out vanes to reduce the pressure and entry of foreign materials into the mechanical seal area. In addition, a lip seal shall be located behind the impeller hub to further reduce the entry of foreign materials into the seal area. Impellers shall be direct connected to the motor shaft with a slip fit, key driven, and secured with an impeller bolt. The design shall include a replaceable cast iron suction cover. The suction cover shall contain a groove(s) perpendicular to the suction opening to disrupt fibrous solids that may otherwise become lodged between the impeller and suction cover. The suction cover shall be designed such that it may be adjusted to maintain working clearances and hydraulic efficiencies.
- f. For units 7½ to 30 HP, the impeller shall be a mixed flow multi-vane semi-open design. It shall be dynamically balanced and shall be designed for solids handling with a long throulet without acute turns. The inlet edge of the impeller vanes shall be angled toward the impeller periphery so as to facilitate the release of objects that might otherwise clog the pump. The 7½ to 30 HP impeller design shall also include back pump out vanes to reduce the pressure and entry of foreign materials into the mechanical seal area. In addition, a lip seal shall be located behind the impeller hub to further reduce the entry of foreign materials into the seal area. Impellers shall be direct connected to the motor shaft with a slip fit, key driven, and secured with an impeller bolt. The design shall include a replaceable cast iron suction cover. The suction cover shall contain a groove(s) perpendicular to the suction opening to disrupt fibrous solids that may otherwise become lodged between the impeller and suction cover. The suction cover shall be designed such that it may be adjusted to maintain working clearances and hydraulic efficiencies.

2. Mechanical Seals

- a. For units 2 to 5 HP, double mechanical seals operating in an oil bath shall be provided on all units. The oil filled seal chamber shall be designed to prevent over-filling and include an anti-vortexing vane to insure proper lubrication of both seal faces. Lower face materials shall be silicon carbide, upper faces carbon vs. ceramic, NBR elastomers, and 304SS hardware. Seal system shall not rely on pumping medium for lubrication.
- b. Units 7½ to 60 HP shall be designed to include a double mechanical seal in a tandem arrangement. Each seal shall be positively driven and act independently with its own spring system. The upper seal operates in an oil bath, while the lower seal is lubricated by the oil from between the shaft and the seal faces, and in contact with



Specifications

the pumpage. The oil filled seal chamber shall be designed to prevent over-filling and include an anti-vortexing vane to insure proper lubrication of both seal faces. Lower face materials shall be silicon carbide (tungsten carbide for 150-300 DLFU 50 & 60 HP only), upper faces carbon vs. ceramic, NBR elastomers, and 304SS hardware. Seal system shall not rely on pumping medium for lubrication.

E. Motor Construction:

The pump motor shall be FM Explosion Proof, Class 1, Division 1, Groups C, D. The design shall be an air filled induction type with a squirrel cage rotor, shell type design, built to NEMA MG-1, Design B specifications. Stator windings shall be copper, insulated with moisture resistant Class H insulation, rated for 356°F. The stator shall be dipped and baked three times in Class H varnish and heat shrunk fitted into the stator housing. Rotor bars and short circuit rings shall be manufactured of cast aluminum. Motor shaft shall be one piece AISI403 material for 2 to 5 HP, AISI420 for 7½ to 60 HP material, rotating on two permanently lubricated ball bearings designed for a minimum B-10 life of 60,000 hours. Motor service factor shall be 1.15 and capable of up to 20 starts per hour. The motor shall be designed for continuous duty pumping at a maximum sump temperature of 104°F. Voltage and frequency tolerances shall be a maximum 10 / 5% respectively. Motor over temperature protection shall be provided by miniature thermal protectors embedded in the windings. Mechanical seal failure protection shall be provided by a mechanical float switch located in a chamber above the seal. This switch shall be comprised of a magnetic float that actuates a dry reed switch encapsulated within the stem. Should the mechanical seal fail, liquid shall be directed into the float chamber, in which the rising liquid activates the switch opening the normally closed circuit. For units 2 to 10 HP the float body and float shall be a polypropylene material with a 316SS stopper. Units 15 HP and greater, the float switch components shall be 304SS. The motor shall be non-overloading over the entire specified range of operation and be able to operate at full load intermittently while unsubmerged without damage to the unit.

Power cable jacket shall be manufactured of an oil resistant chloroprene rubber material, designed for submerged applications. Cable shall be watertight to a depth of at least 65'. The cable entry system shall comprise of primary, secondary, and tertiary sealing methods. The primary seal shall be achieved by a cylindrical elastomeric grommet compressed between the motor cover and a 304SS washer. Secondary sealing is accomplished with a compressed O-ring made of NBR material. Compression and subsequent sealing shall preclude specific torque requirements. The system shall also include tertiary sealing to prevent leakage into the motor housing due to capillary action through the insulation if the cable is damaged or cut. The cable wires shall be cut, stripped, re-connected with a copper butt end connector, and embedded in epoxy within the cable gland. This provides a dead end for leakage through the cable insulation into the motor junction area. The cable entry system shall be the same for both the power and control cables.

F. Guide Rail system:

Design shall include two (2) 304SS schedule 40 guide rails sized to mount directly to the quick discharge connector, QDC, at the floor of the wetwell and to a guide rail bracket at the top of the wetwell below the hatch opening, (refer to project drawings). Intermediate guide brackets are recommended for rail lengths over 15 feet.

Guide rails are not part of the pump package and shall be supplied by others.

The QDC shall be manufactured of cast iron, ASTM A48 Class 30. It shall be designed to adequately support the guide rails, discharge piping, and pumping unit under both static and dynamic loading conditions with support legs that are suitable for anchoring it to the wetwell floor. The face of the inlet QDC flange shall be perpendicular to the floor of the wetwell. The discharge flange of the QDC shall conform to ANSI B16.1 Class 125.

The pump design shall include an integral self-aligning sliding bracket. Sealing of the pumping unit to the QDC shall be accomplished by a single, linear, downward motion of the pump. The entire weight of the pump unit shall be guided to and wedged tightly against the inlet flange of the QDC, making metal to metal contact with the pump discharge forming a seal without the use of bolts, gaskets or O-rings.

A stainless steel lifting chain of adequate length for removing and installing the pump unit is recommended. The chain shall have a round link with a 2-¼" inside diameter every two feet. This link will allow for a sliding pinch bar through the link to pick the chain, more than once if necessary, at multiple intervals during pump removal and installation.



Selection Chart

Model DLFU
Three Phase 60Hz

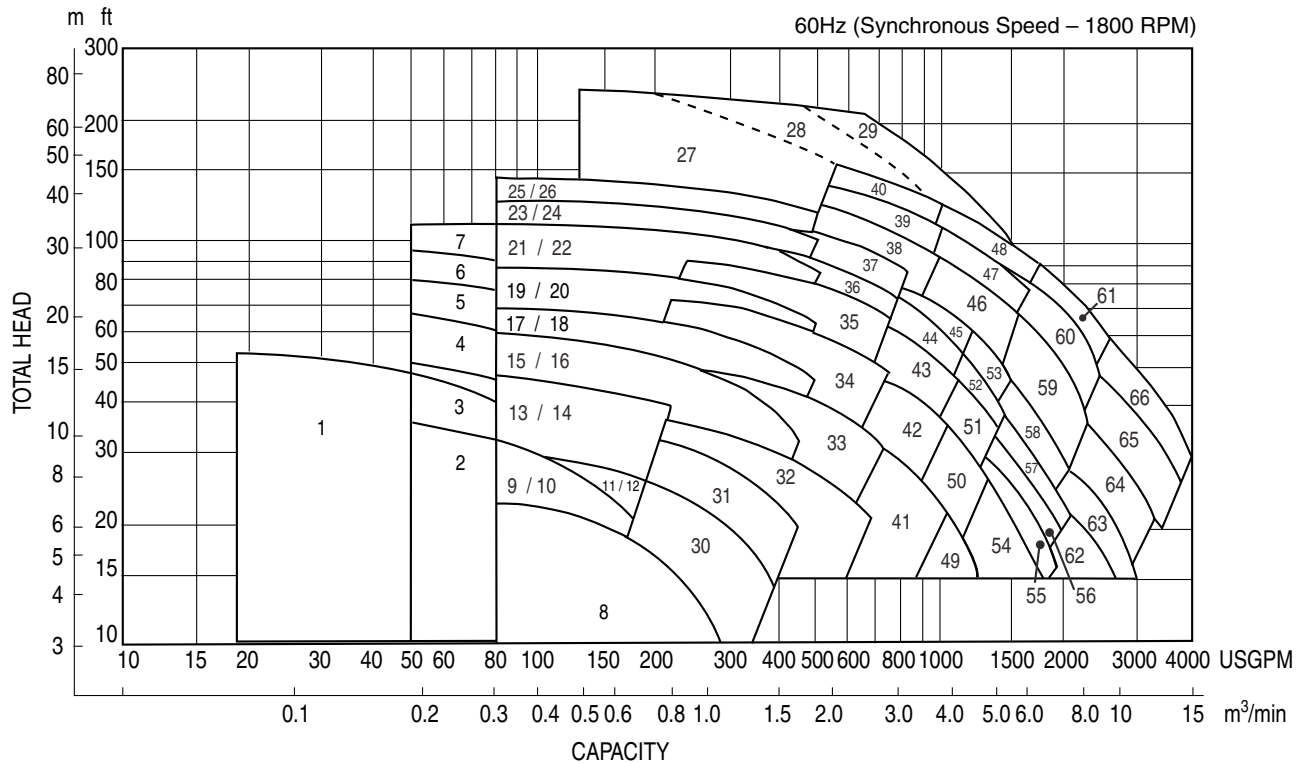

Please note: Overlap in coverage is designated by the two numbers; for example "9 / 10". Refer to the legend below for the specific model numbers.

1 50DLFU61.5 2HP	19 80DLFU611 15HP	37 100DLFU622 30HP	55 250DLBFU615 20HP
2 80DLMFU61.5 2HP	20 100DLMFU611 15HP	38 150DLFU630 40HP	56 250DLCFU615 20HP
3 80DLMFU62.2 3HP	21 80DLFU615 20HP	39 150DLFU637 50HP	57 250DLFU618 25HP
4 80DLMFU63.7 5HP	22 100DLMFU615 20HP	40 150DLFU645 60HP	58 250DLFU622 30HP
5 80DLMFU65.5 7½HP	23 80DLFU618 25HP	41 150DLFU67.5 10HP	59 250DLFU630 40HP
6 80DLCMFU67.5 10HP	24 100DLMFU618 25HP	42 150DLFU611 15HP	60 250DLFU637 50HP
7 80DLCMFU611 15HP	25 80DLFU622 30HP	43 150DLFU615 20HP	61 250DLFU645 60HP
8 100DLFU61.5 2HP	26 100DLMFU622 30HP	44 150DLFU618 25HP	62 300DLFU618 25HP
9 80DLFU61.5 2HP	27 100DLFU630 40HP	45 150DLFU622 30HP	63 300DLFU622 30HP
10 100DLMFU61.5 2HP	28 100DLFU637 50HP	46 200DLFU630 40HP	64 300DLFU630 40HP
11 80DLFU62.2 3HP	29 100DLFU645 60HP	47 200DLFU637 50HP	65 300DLFU637 50HP
12 100DLMFU62.2 3HP	30 100DLFU62.2 3HP	48 200DLFU645 60HP	66 300DLFU645 60HP
13 80DLFU63.7 5HP	31 100DLFU63.7 5HP	49 200DLFU67.5 10HP	
14 100DLMFU63.7 5HP	32 100DLFU65.5 7½HP	50 200DLFU611 15HP	
15 80DLFU65.5 7½HP	33 100DLFU67.5 10HP	51 200DLFU615 20HP	
16 100DLMFU65.5 7½HP	34 100DLFU611 15HP	52 200DLFU618 25HP	
17 80DLFU67.5 10HP	35 100DLFU615 20HP	53 200DLFU622 30HP	
18 100DLMFU67.5 10HP	36 100DLFU618 25HP	54 250DLFU611 15HP	

Performance Curves

Project: _____ GPM: _____ TDH: _____ EFF: _____ HP: _____ Chk'd: _____ Date: _____

50DLF61.5 (2HP) Synchronous Speed: 1800 RPM

2, 3 inch Discharge

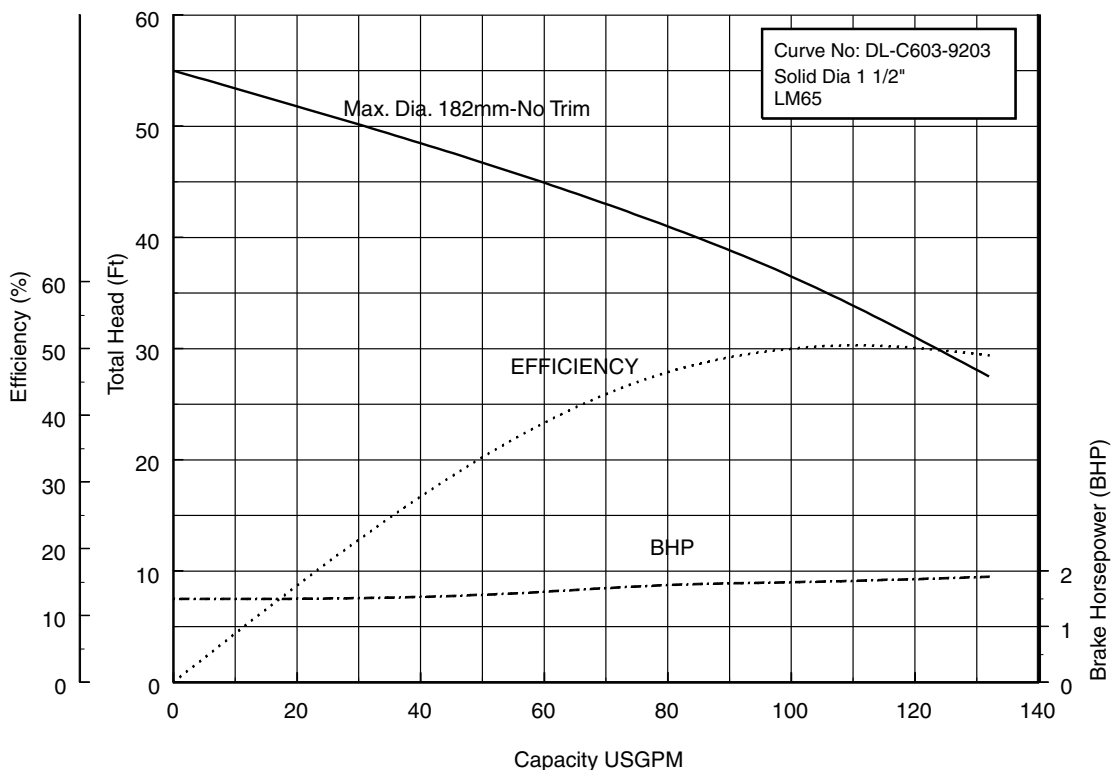

80DLF61.5 (2HP) Synchronous Speed: 1800 RPM

3, 4 inch Discharge

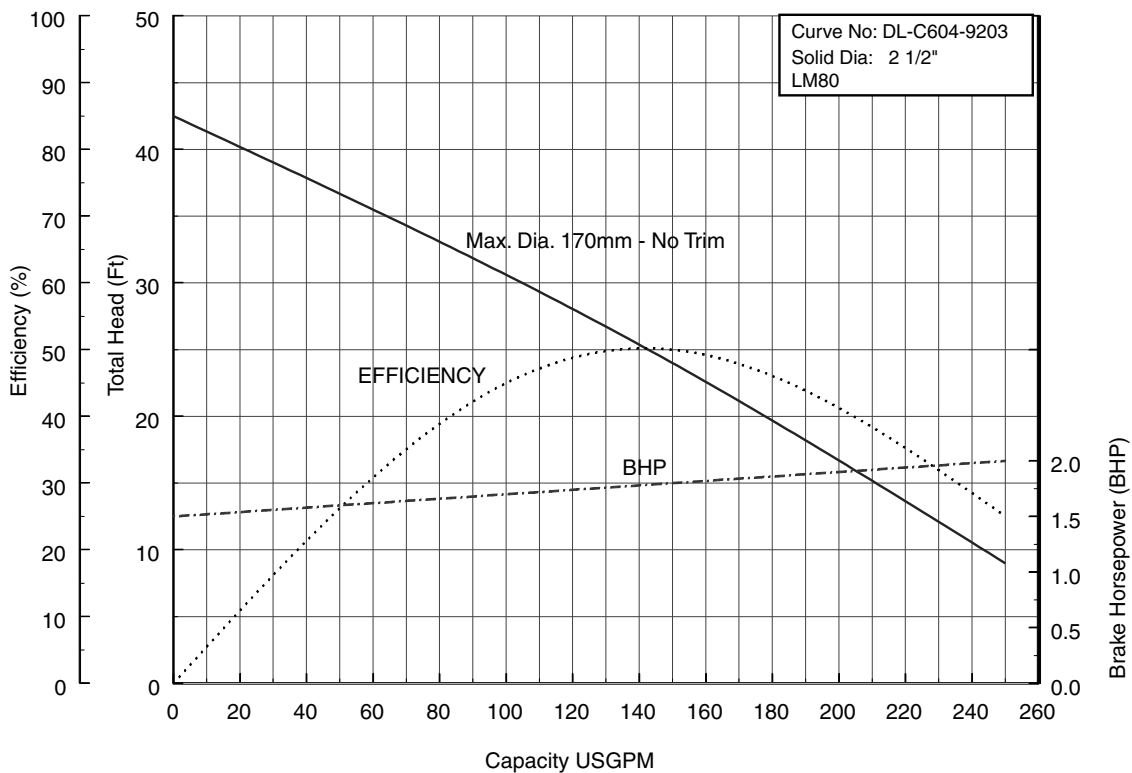

Performance Curves

Project: _____ GPM: _____ TDH: _____ EFF: _____ HP: _____ Chk'd: _____ Date: _____

80DLMF61.5 (2HP) Synchronous Speed: 1800 RPM

3, 4 inch Discharge

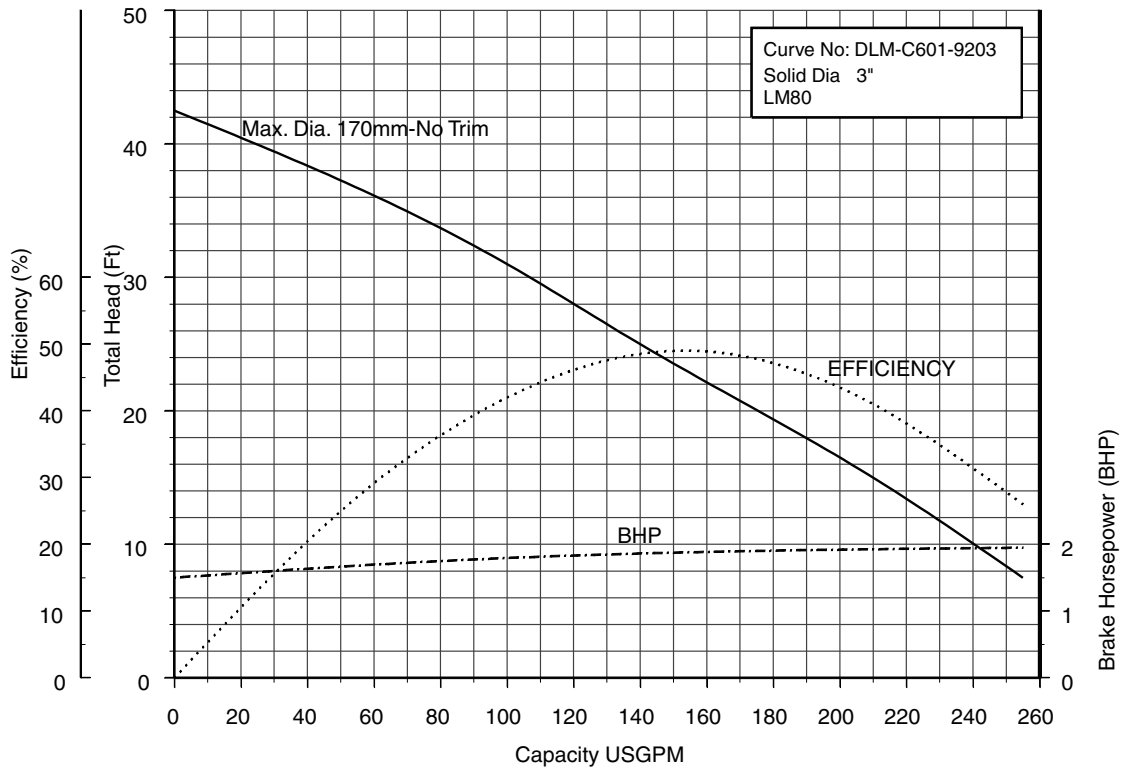

80DLF62.2 (3HP) Synchronous Speed: 1800 RPM

3, 4 inch Discharge

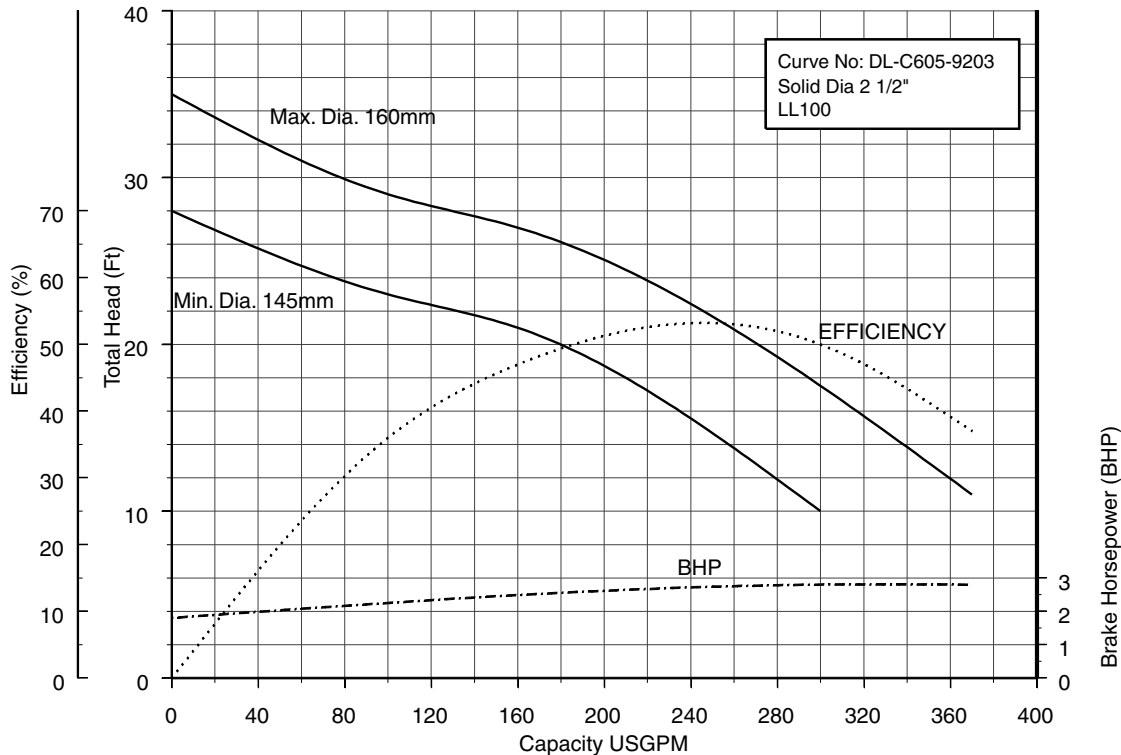

Performance Curves

Project: _____ GPM: _____ TDH: _____ EFF: _____ HP: _____ Chk'd: _____ Date: _____

80DLMF62.2 (3HP) Synchronous Speed: 1800 RPM

3, 4 inch Discharge

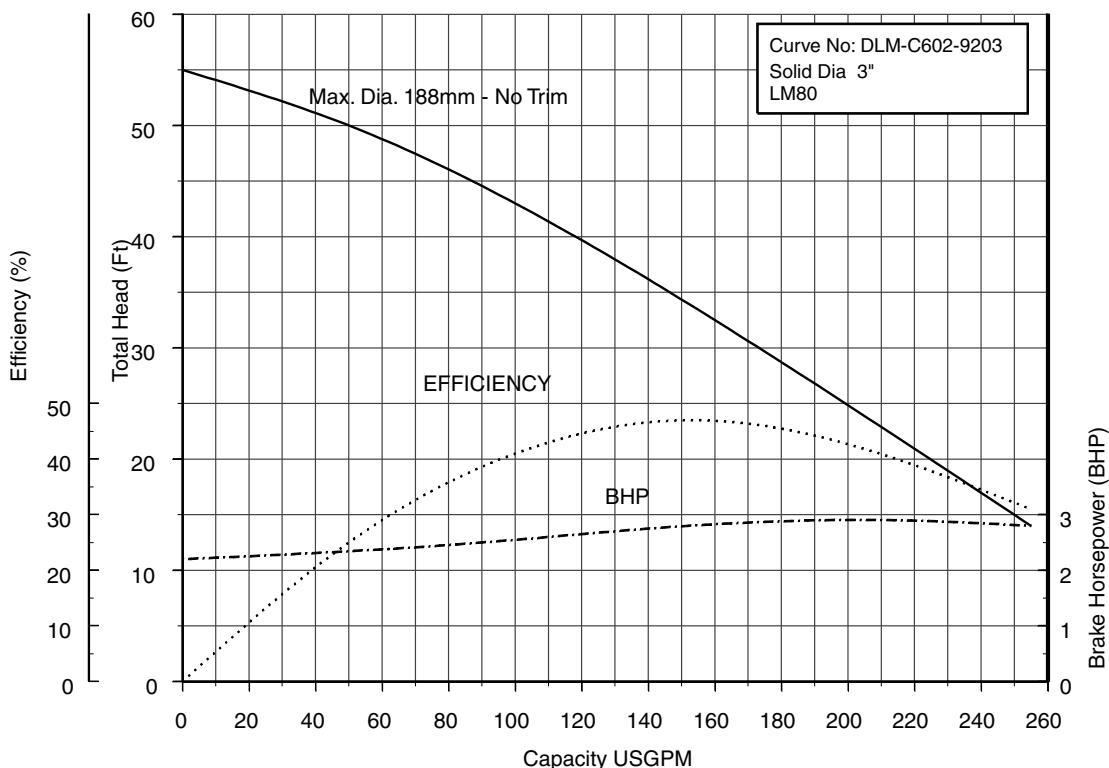

80DLF63.7 (5HP) Synchronous Speed: 1800 RPM

3, 4 inch Discharge

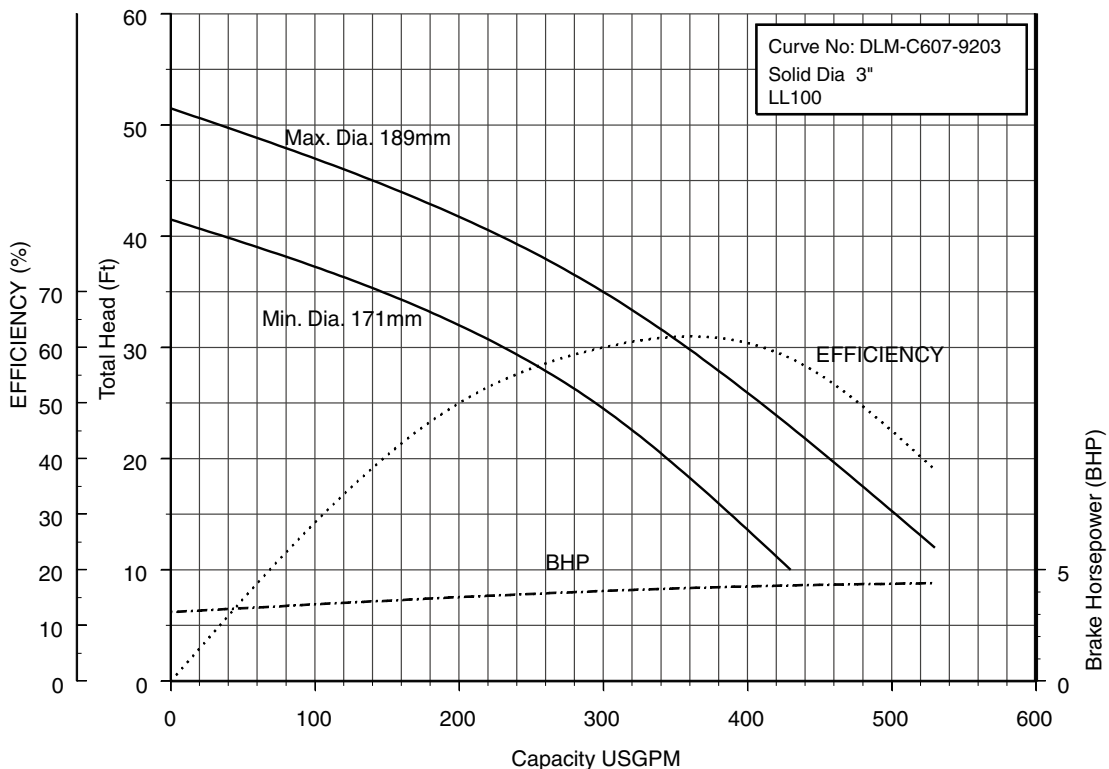

Performance Curves

Project: _____ GPM: _____ TDH: _____ EFF: _____ HP: _____ Chk'd: _____ Date: _____

80DLMF63.7 (5HP) Synchronous Speed: 1800 RPM

3, 4 inch Discharge

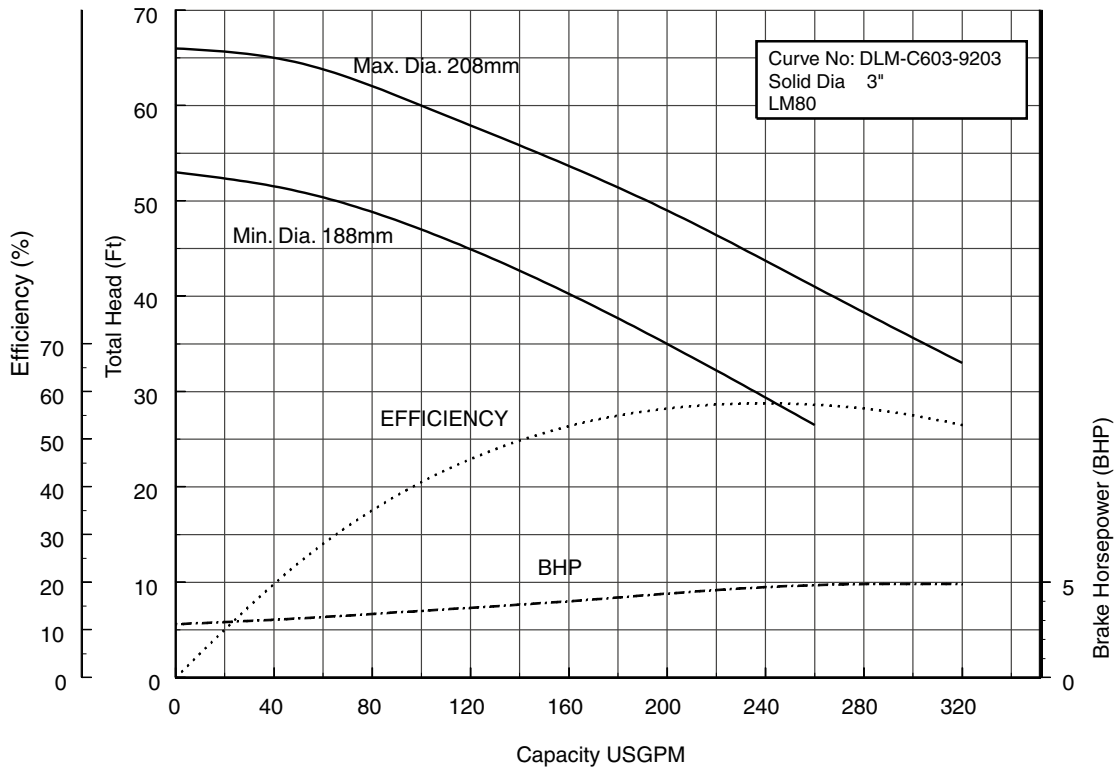

80DLF65.5 (7½HP) Synchronous Speed: 1800 RPM

3, 4 inch Discharge

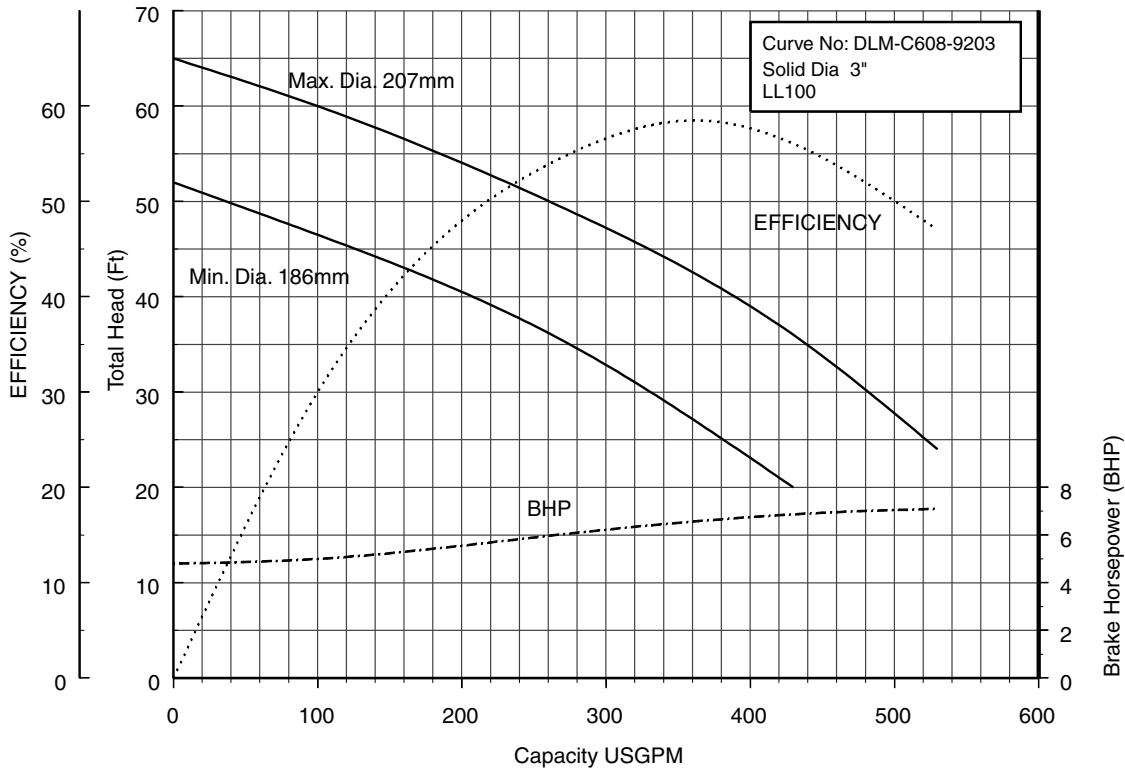

Performance Curves

Project: _____ GPM: _____ TDH: _____ EFF: _____ HP: _____ Chk'd: _____ Date: _____

80DLMF65.5 (7½HP) Synchronous Speed: 1800 RPM

3, 4 inch Discharge

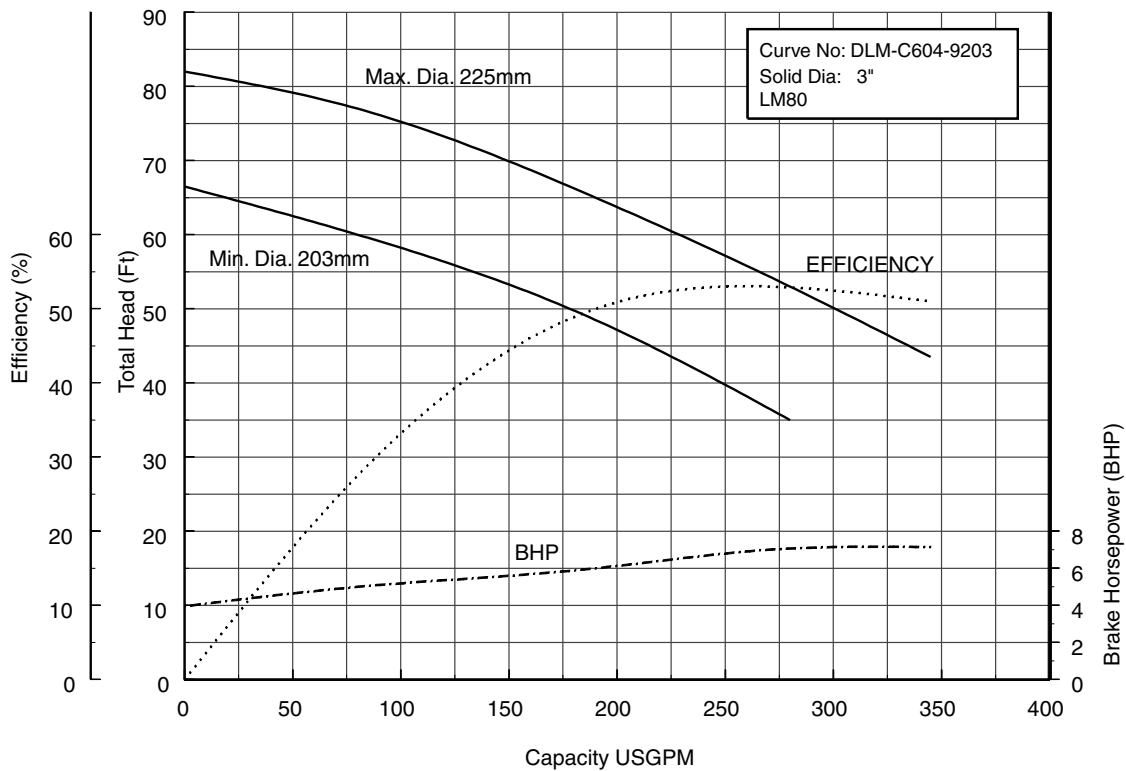

80DLF67.5 (10HP) Synchronous Speed: 1800 RPM

3, 4 inch Discharge

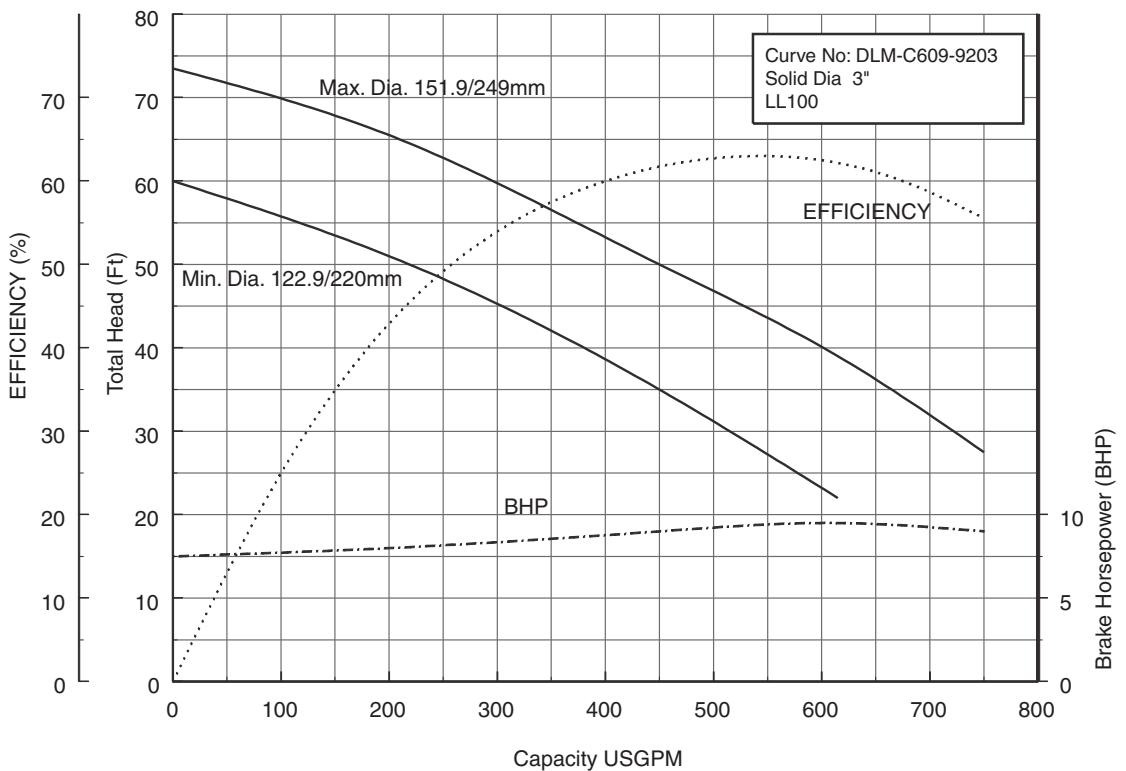

Performance Curves

Project: _____ GPM: _____ TDH: _____ EFF: _____ HP: _____ Chk'd: _____ Date: _____

80DLCMF67.5 (10HP) Synchronous Speed: 1800 RPM

3, 4 inch Discharge

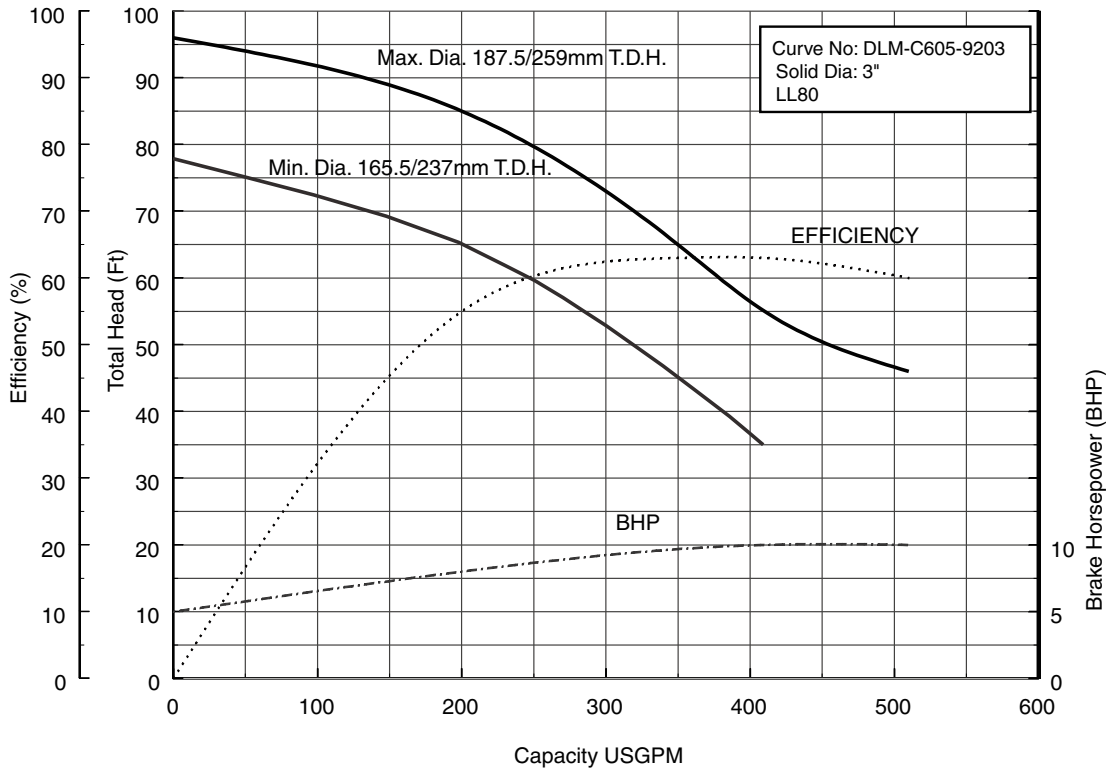

80DLF611 (15HP) Synchronous Speed: 1800 RPM

3, 4 inch Discharge

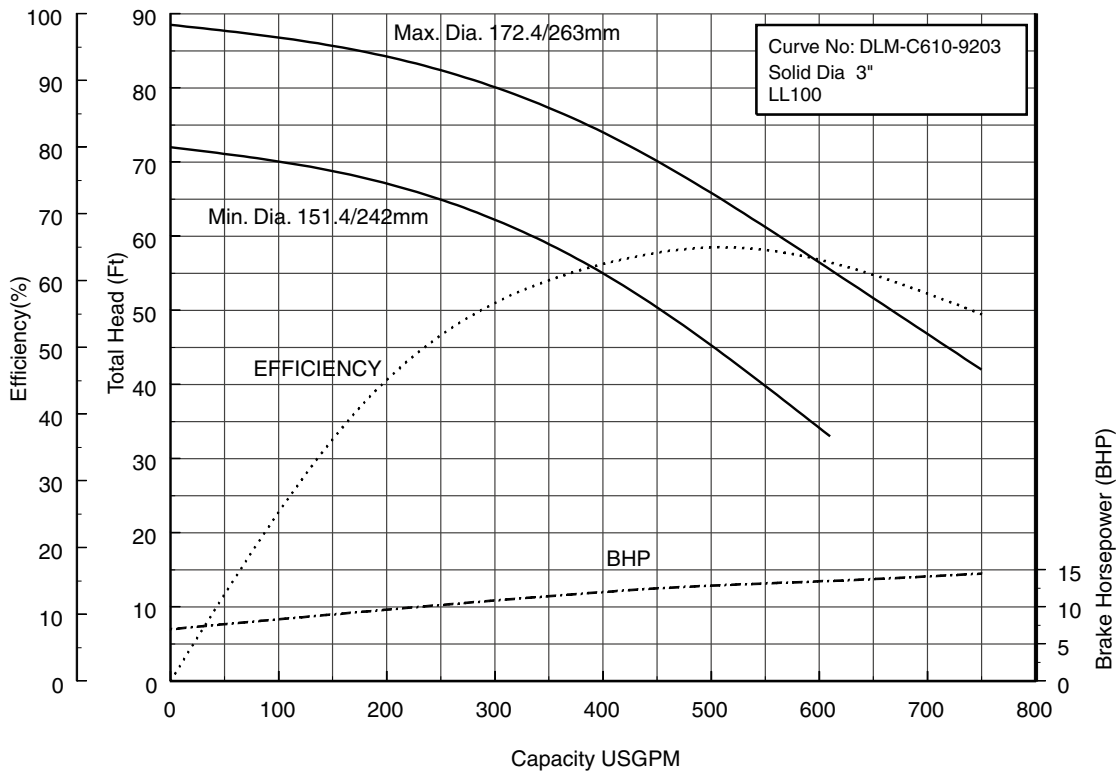

Performance Curves

Project: _____ GPM: _____ TDH: _____ EFF: _____ HP: _____ Chk'd: _____ Date: _____

80DLCMF611 (15HP) Synchronous Speed: 1800 RPM

3, 4 inch Discharge

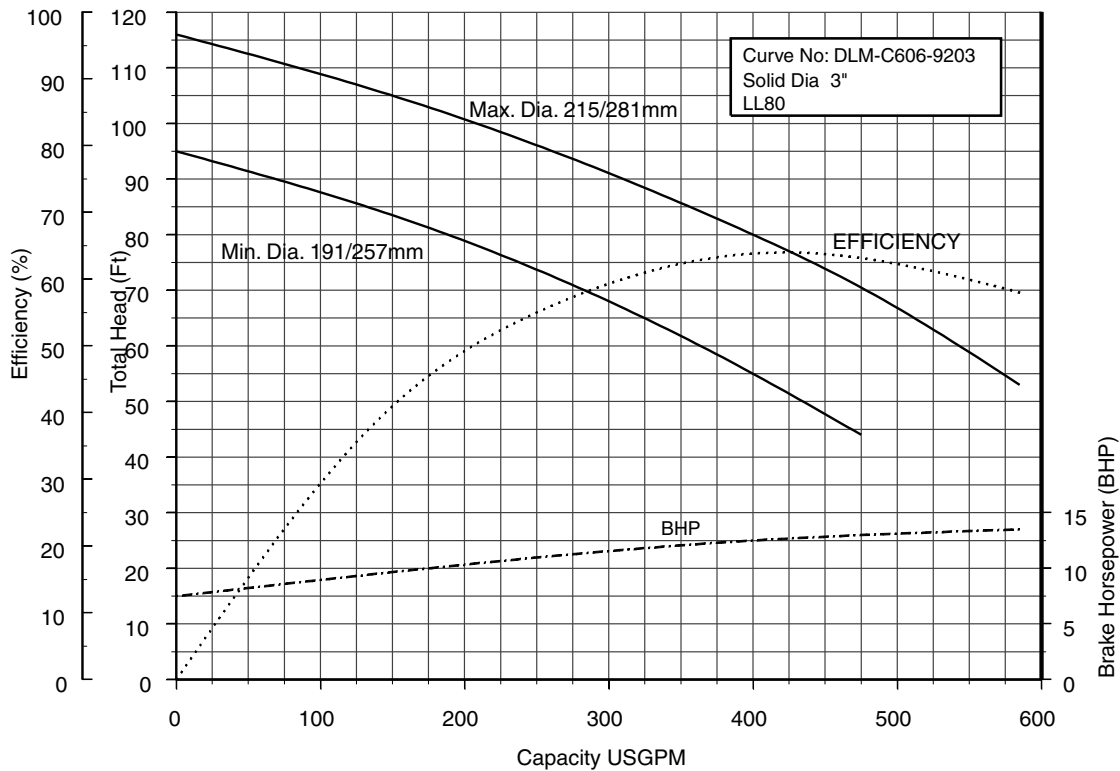

80DLF615 (20HP) Synchronous Speed: 1800 RPM

3, 4 inch Discharge

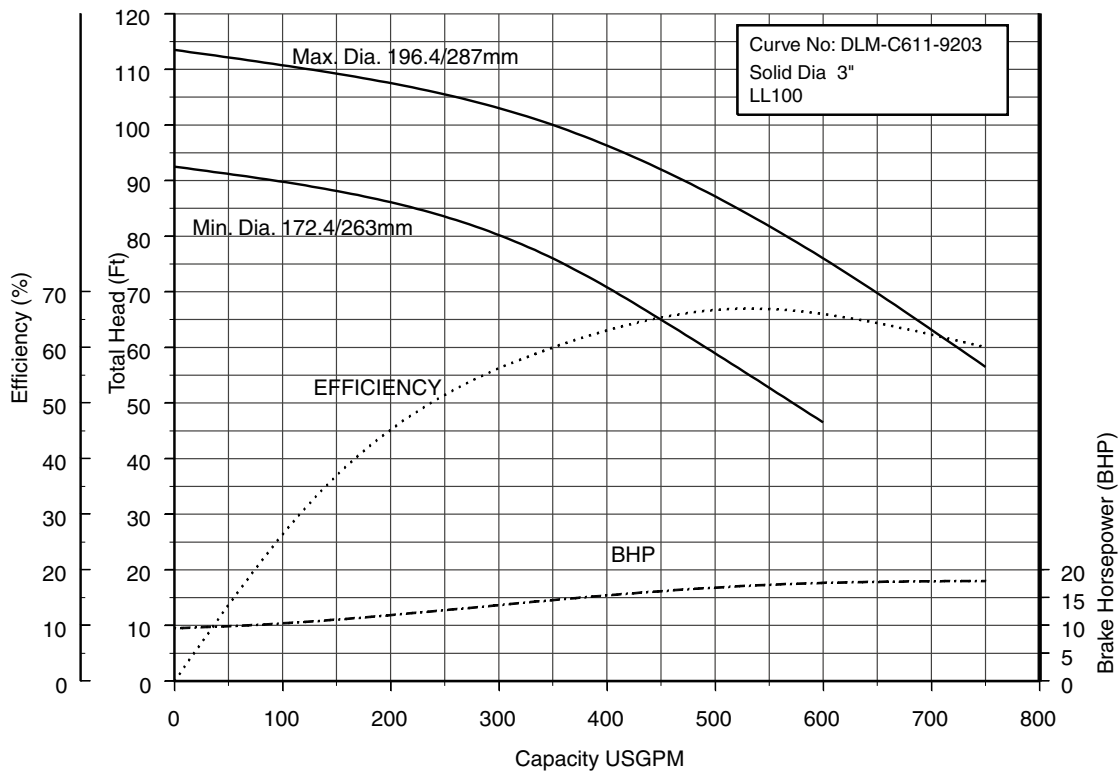

Performance Curves

Project: _____ GPM: _____ TDH: _____ EFF: _____ HP: _____ Chk'd: _____ Date: _____

80DLF618 (25HP) Synchronous Speed: 1800 RPM

3, 4 inch Discharge

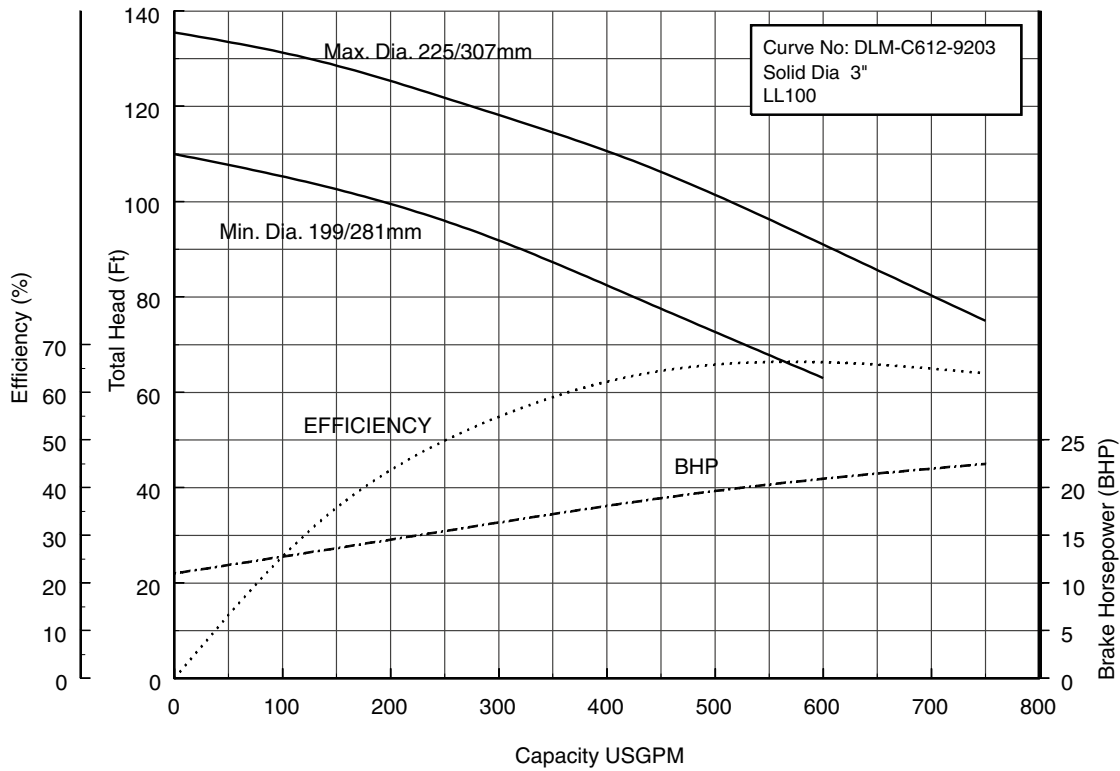

80DLF622 (30HP) Synchronous Speed: 1800 RPM

3, 4 inch Discharge

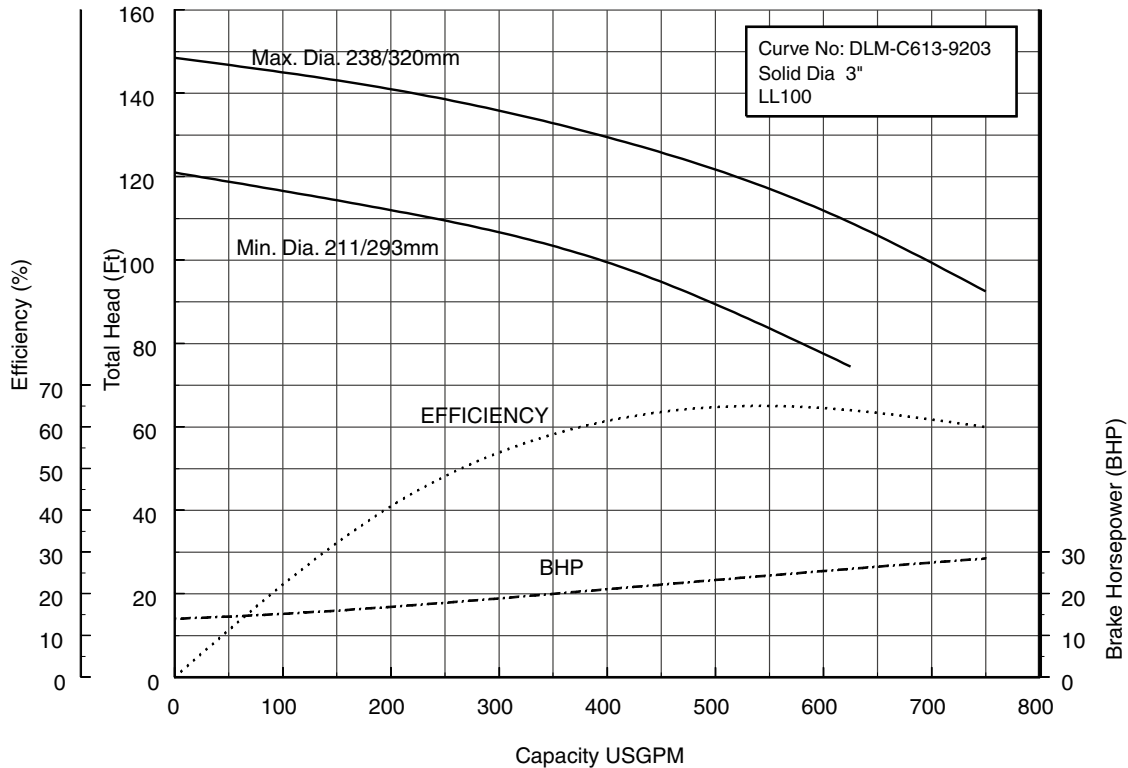

Performance Curves

Project: _____ GPM: _____ TDH: _____ EFF: _____ HP: _____ Chk'd: _____ Date: _____

100DLF61.5 (2HP) Synchronous Speed: 1800 RPM

3, 4 inch Discharge

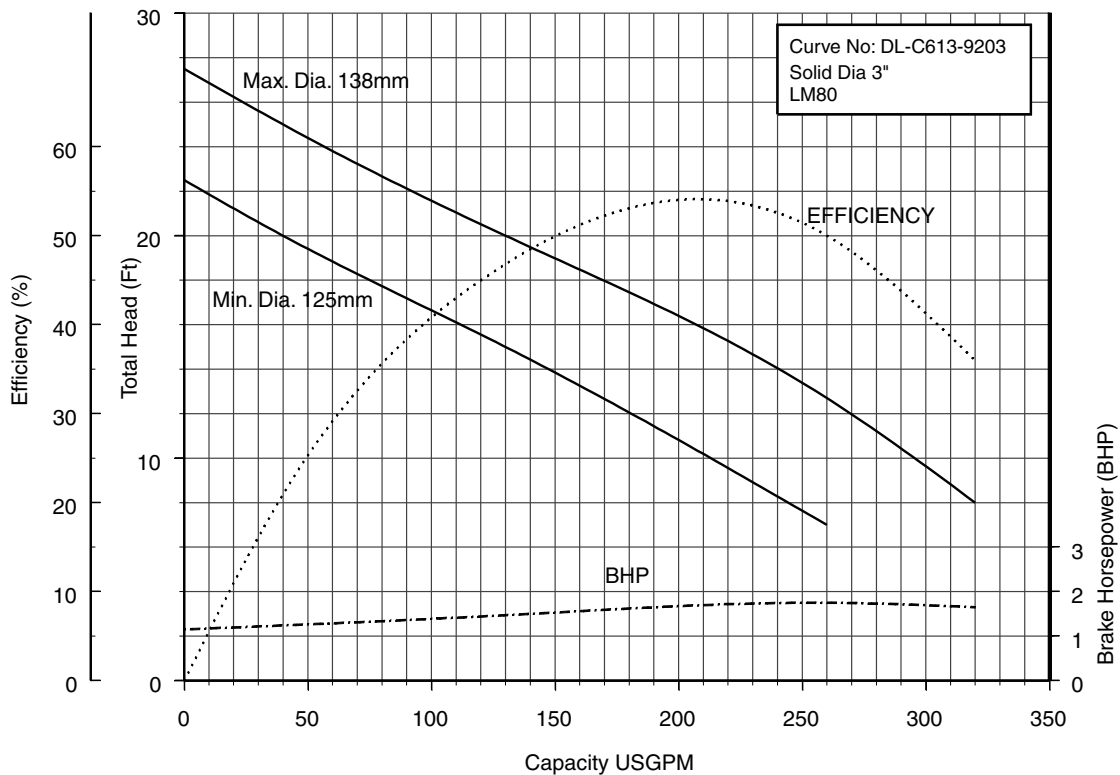

100DLF62.2 (3HP) Synchronous Speed: 1800 RPM

3, 4 inch Discharge

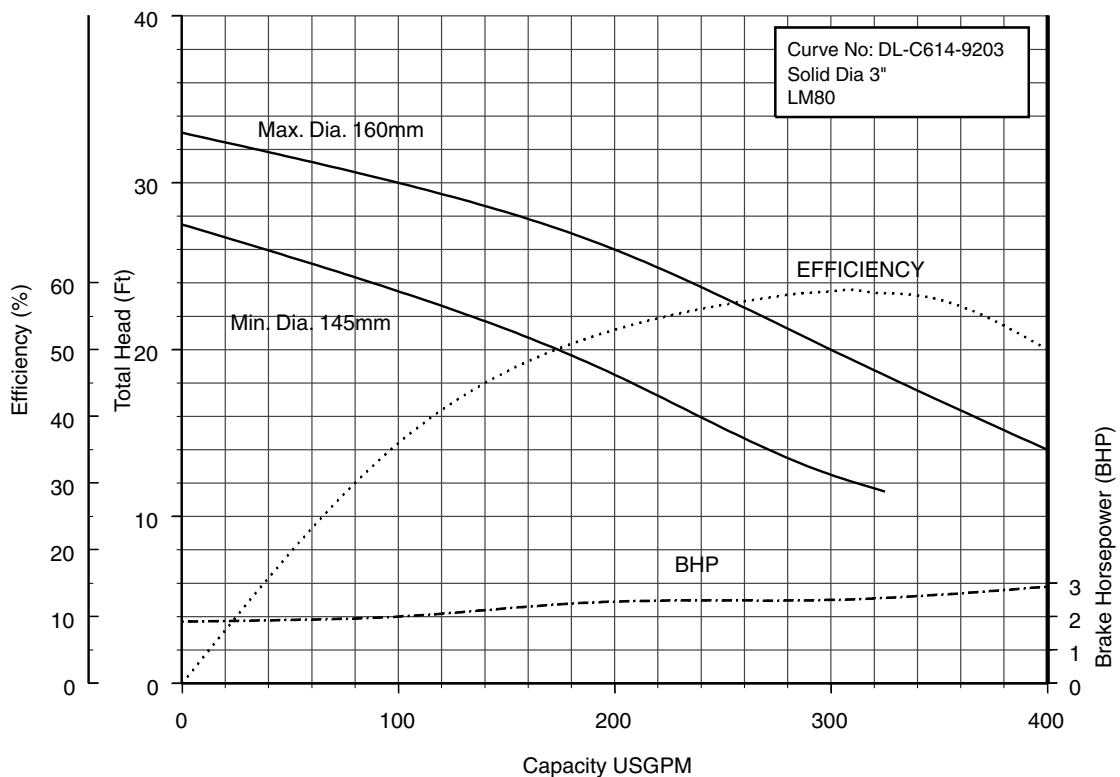

Performance Curves

Project: _____ GPM: _____ TDH: _____ EFF: _____ HP: _____ Chk'd: _____ Date: _____

100DLMF62.2 (3HP) Synchronous Speed: 1800 RPM

3, 4 inch Discharge

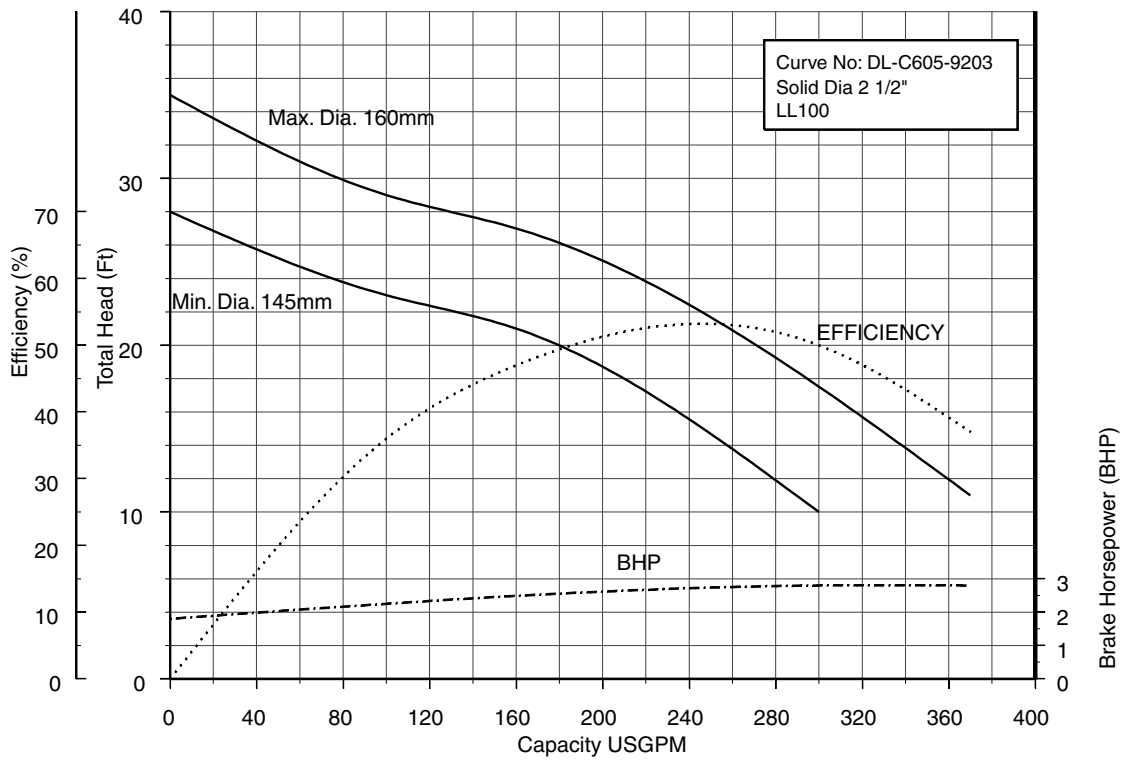

100DLF63.7 (5HP) Synchronous Speed: 1800 RPM

3, 4 inch Discharge

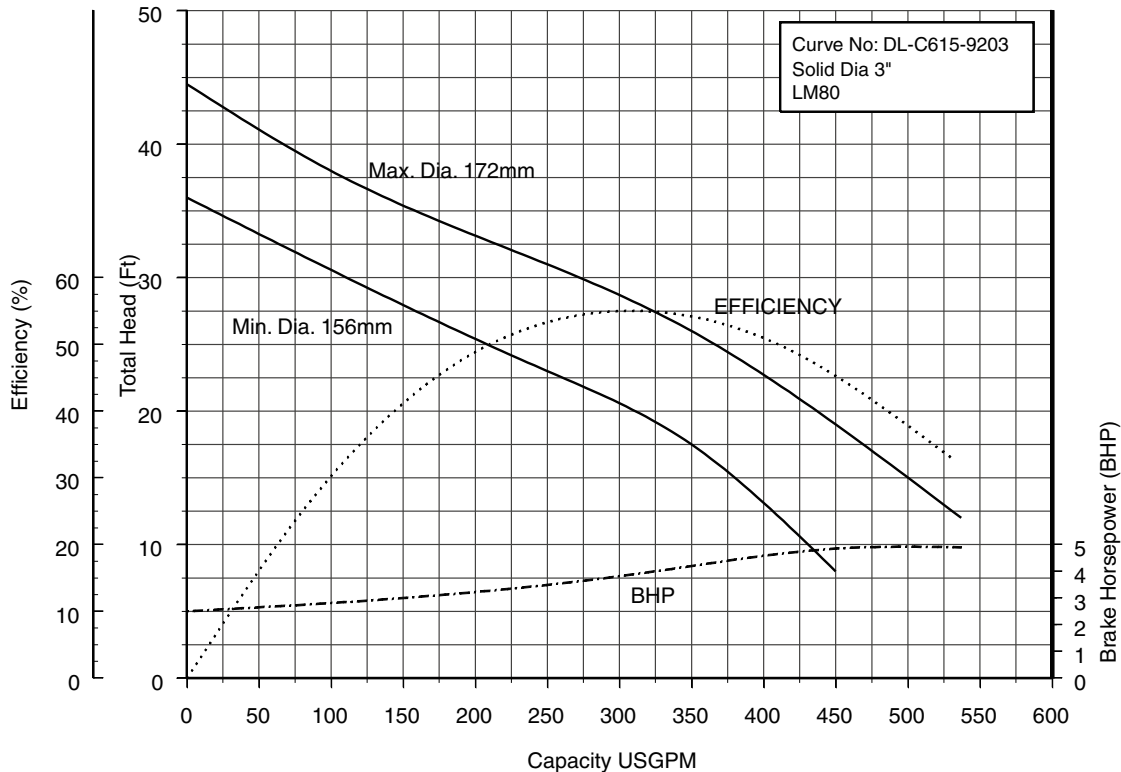

Performance Curves

Project: _____ GPM: _____ TDH: _____ EFF: _____ HP: _____ Chk'd: _____ Date: _____

100DLMF63.7 (5HP) Synchronous Speed: 1800 RPM

3, 4 inch Discharge

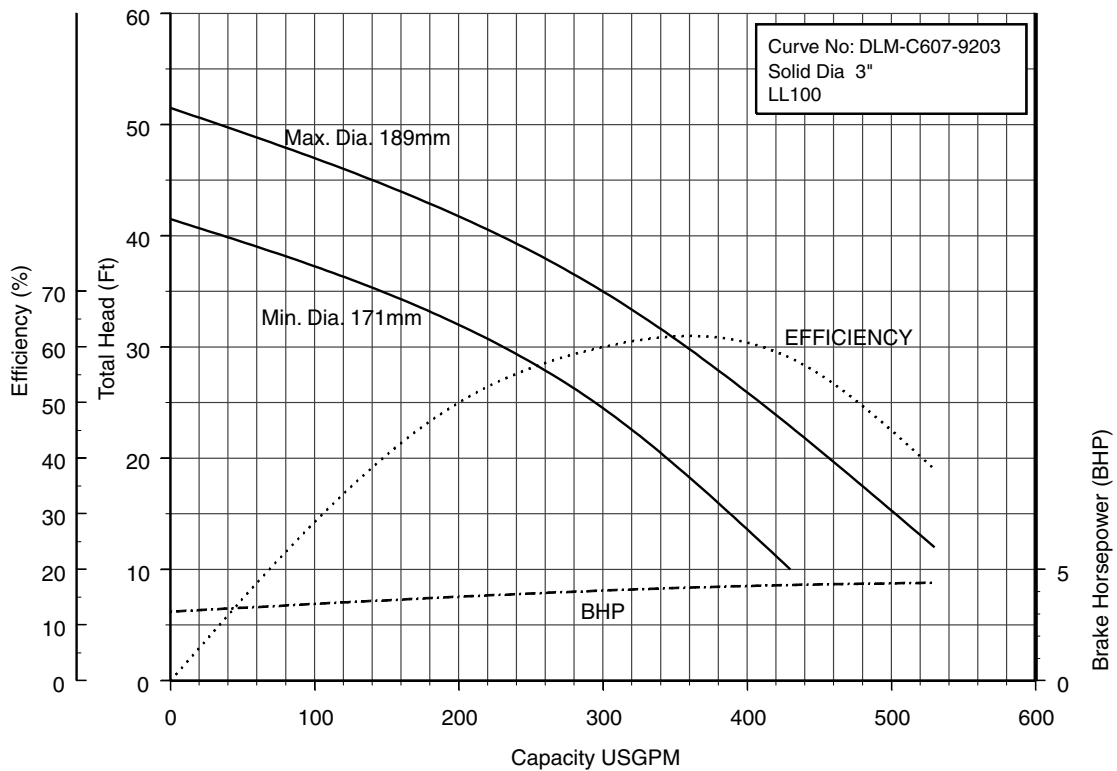

100DLF65.5 (7½HP) Synchronous Speed: 1800 RPM

4, 6 inch Discharge

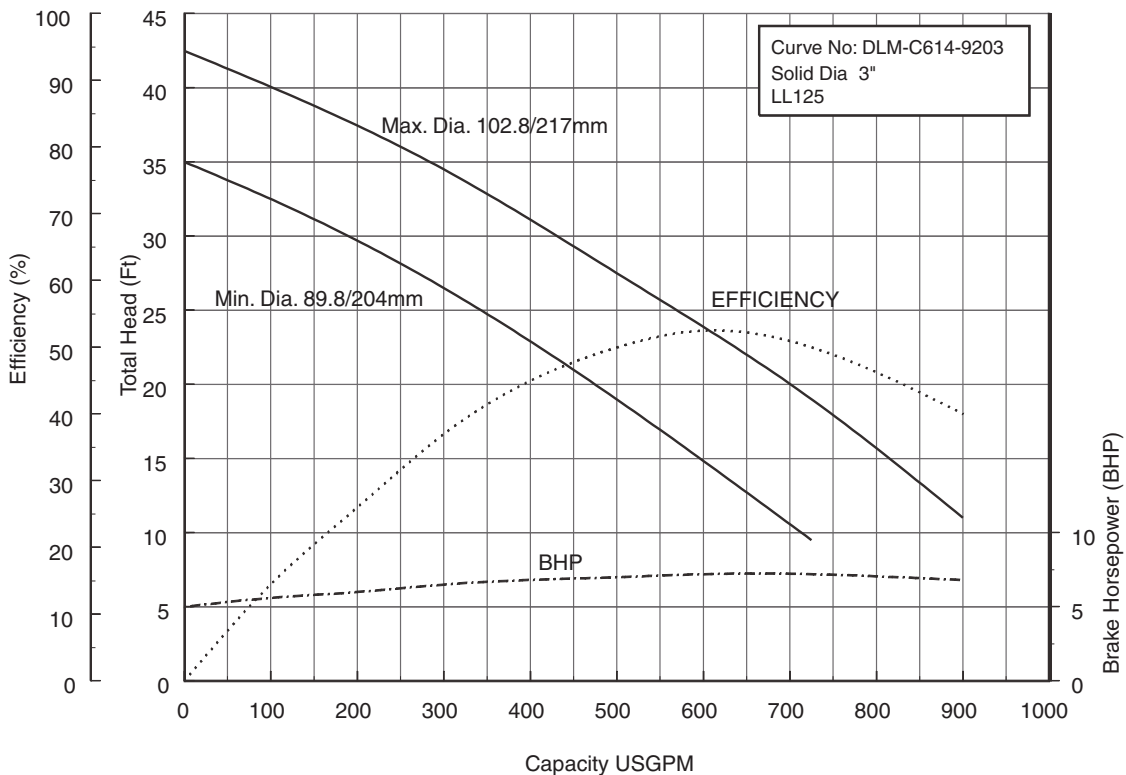

Performance Curves

Project: _____ GPM: _____ TDH: _____ EFF: _____ HP: _____ Chk'd: _____ Date: _____

100DLMF65.5 (7½HP) Synchronous Speed: 1800 RPM

3, 4 inch Discharge

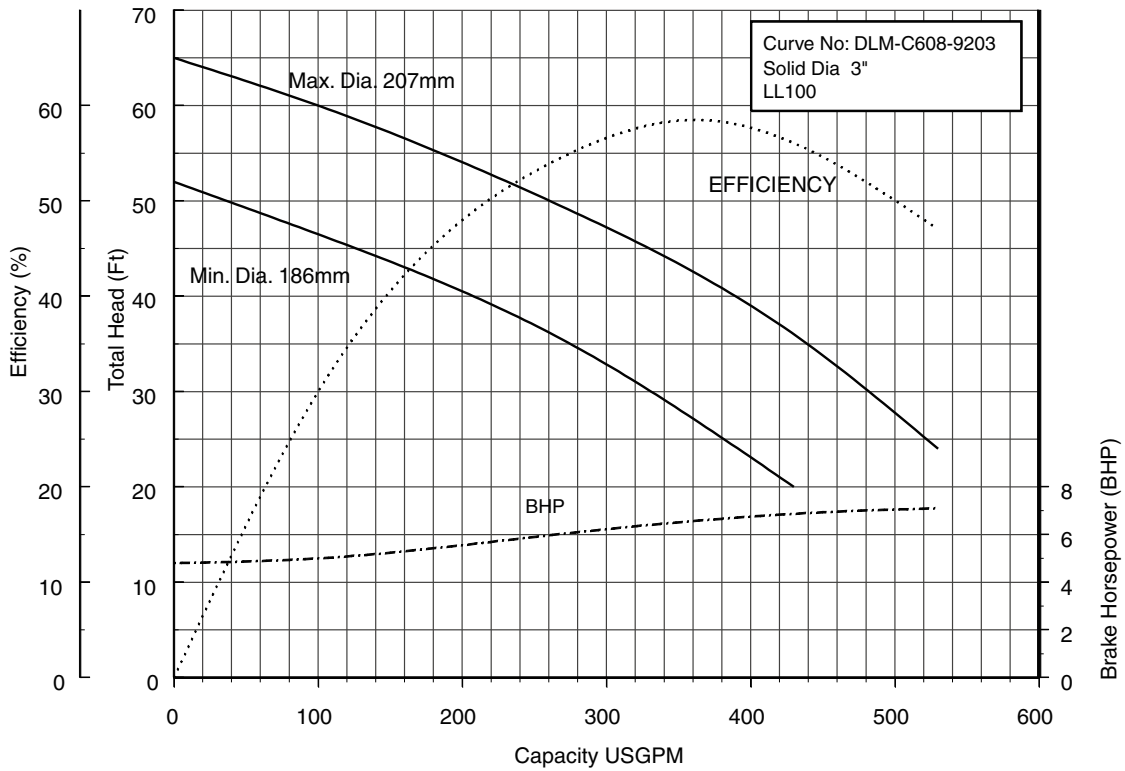

100DLF67.5 (10HP) Synchronous Speed: 1800 RPM

4, 6 inch Discharge

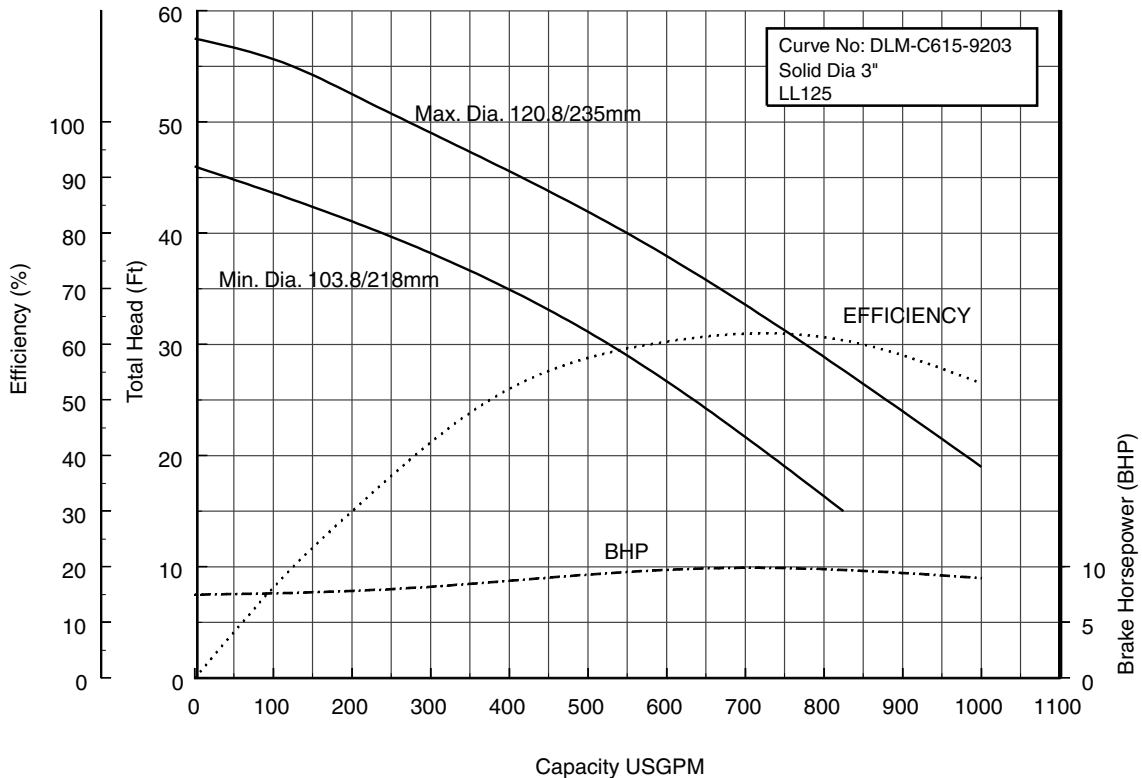

Performance Curves

Project: _____ GPM: _____ TDH: _____ EFF: _____ HP: _____ Chk'd: _____ Date: _____

100DLMF67.5 (10HP) Synchronous Speed: 1800 RPM

3, 4 inch Discharge

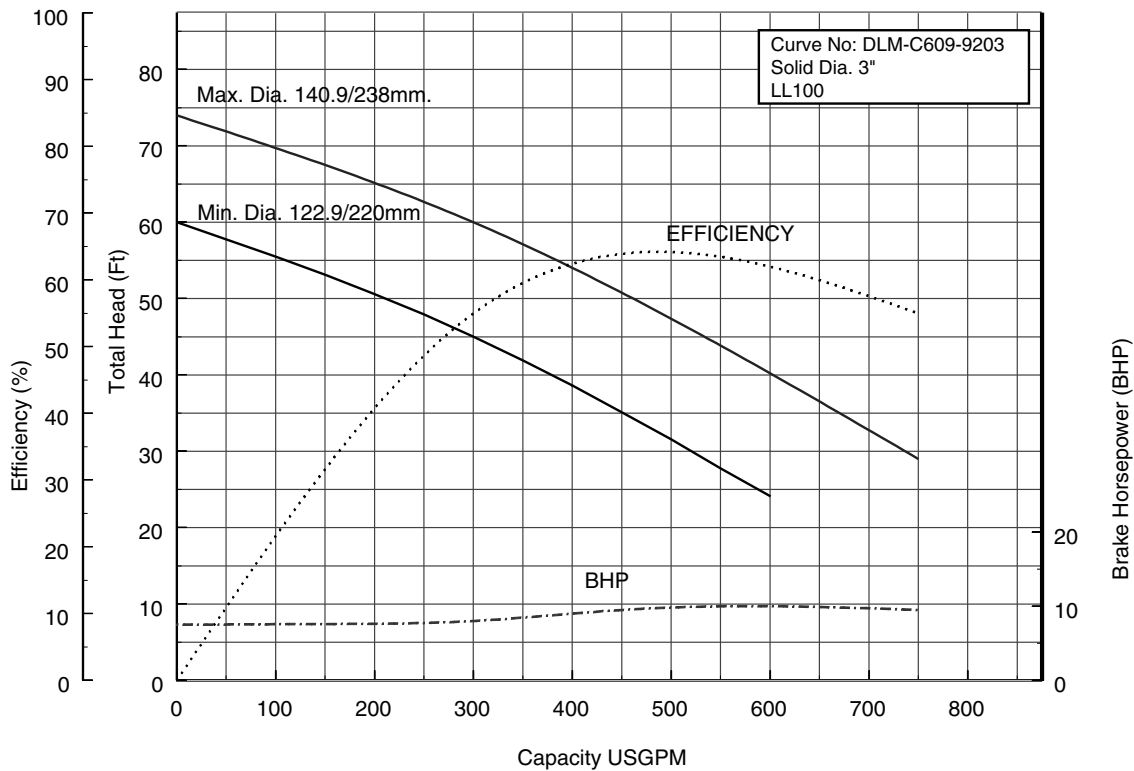

100DLF611 (15HP) Synchronous Speed: 1800 RPM

4, 6 inch Discharge

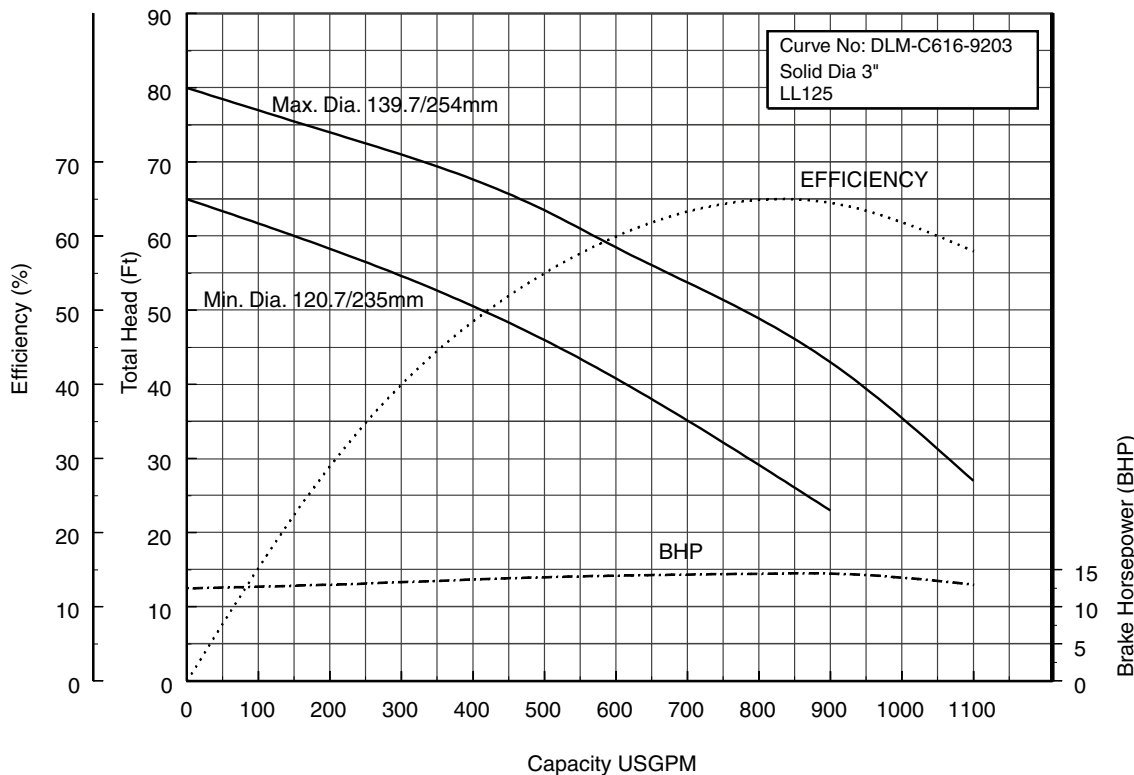

Performance Curves

Project: _____ GPM: _____ TDH: _____ EFF: _____ HP: _____ Chk'd: _____ Date: _____

100DLMF611 (15HP) Synchronous Speed: 1800 RPM

3, 4 inch Discharge

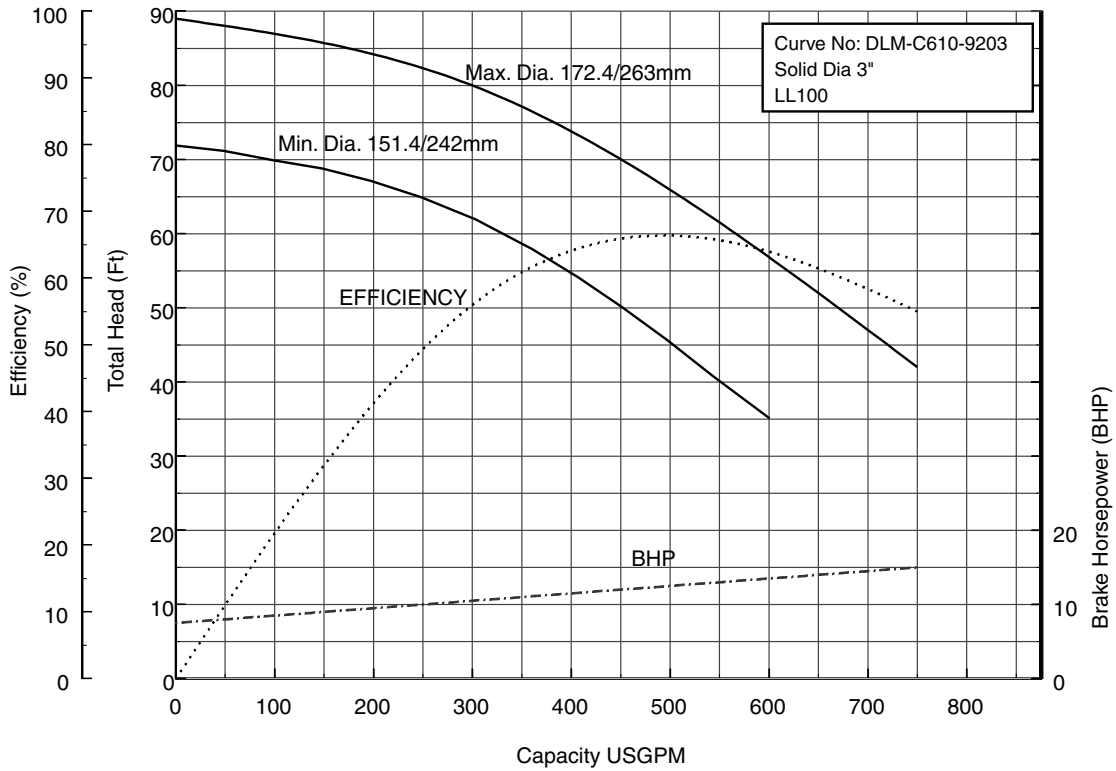

100DLF615 (20HP) Synchronous Speed: 1800 RPM

4, 6 inch Discharge

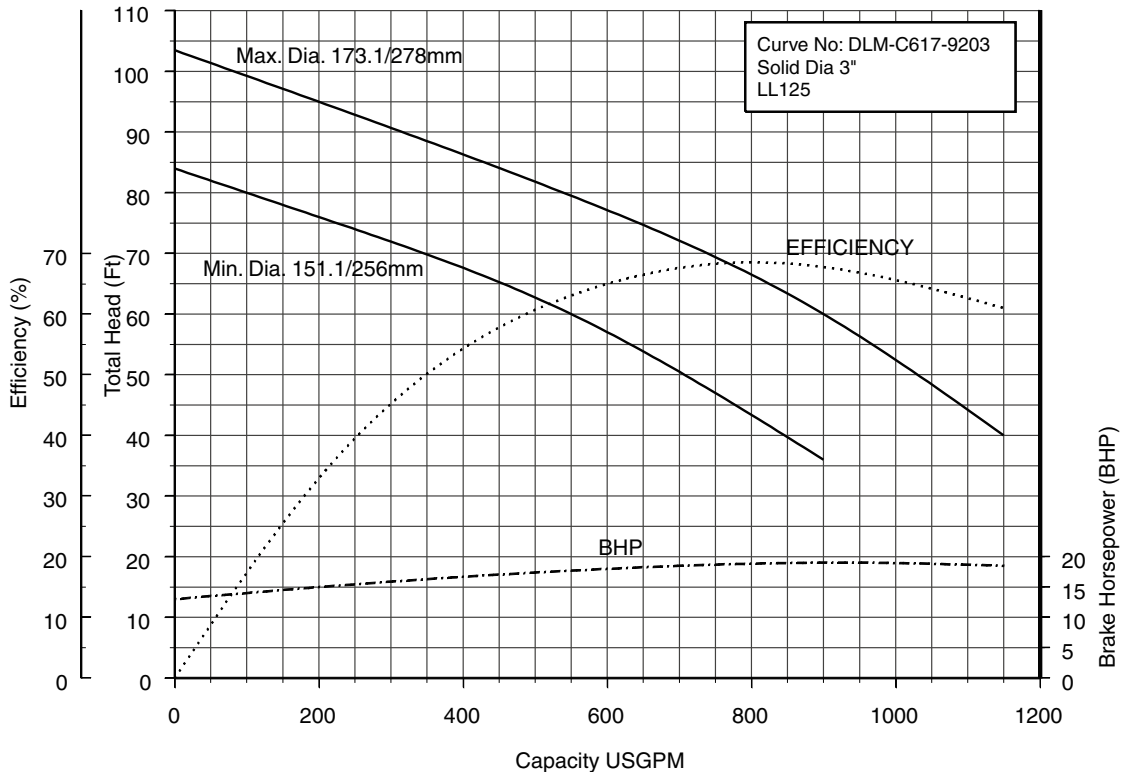

Performance Curves

Project: _____ GPM: _____ TDH: _____ EFF: _____ HP: _____ Chk'd: _____ Date: _____

100DLMF615 (20HP) Synchronous Speed: 1800 RPM

3, 4 inch Discharge

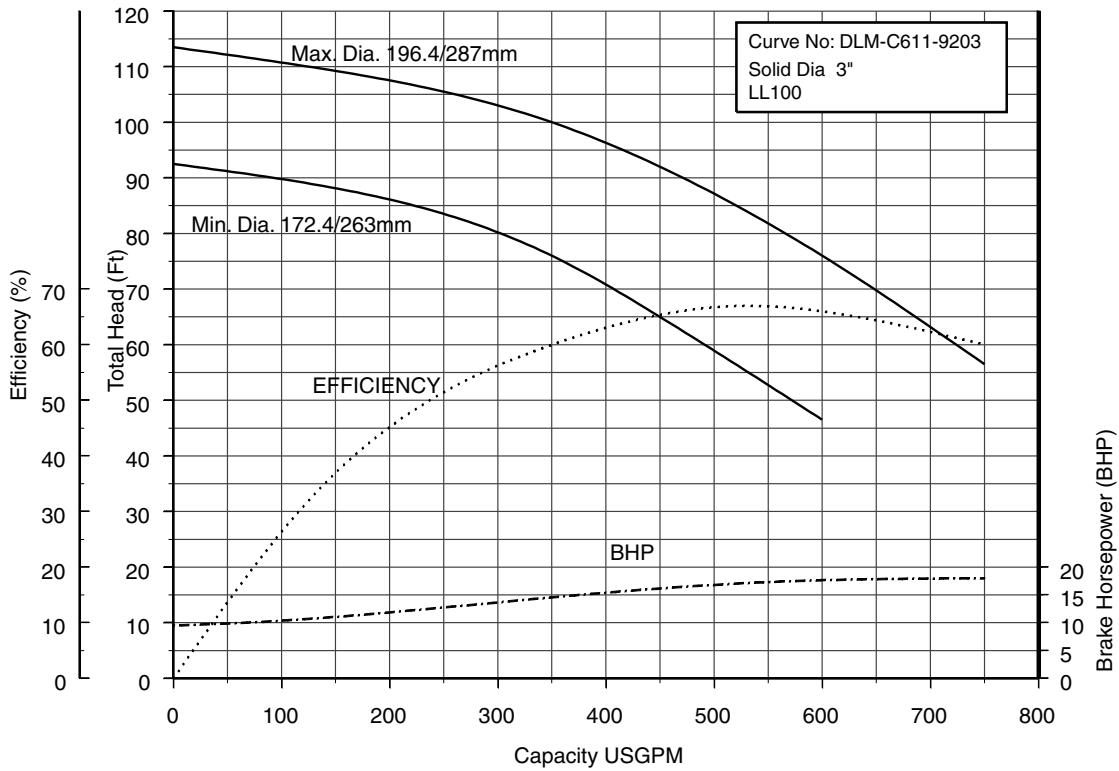

100DLMF618 (25HP) Synchronous Speed: 1800 RPM

3, 4 inch Discharge

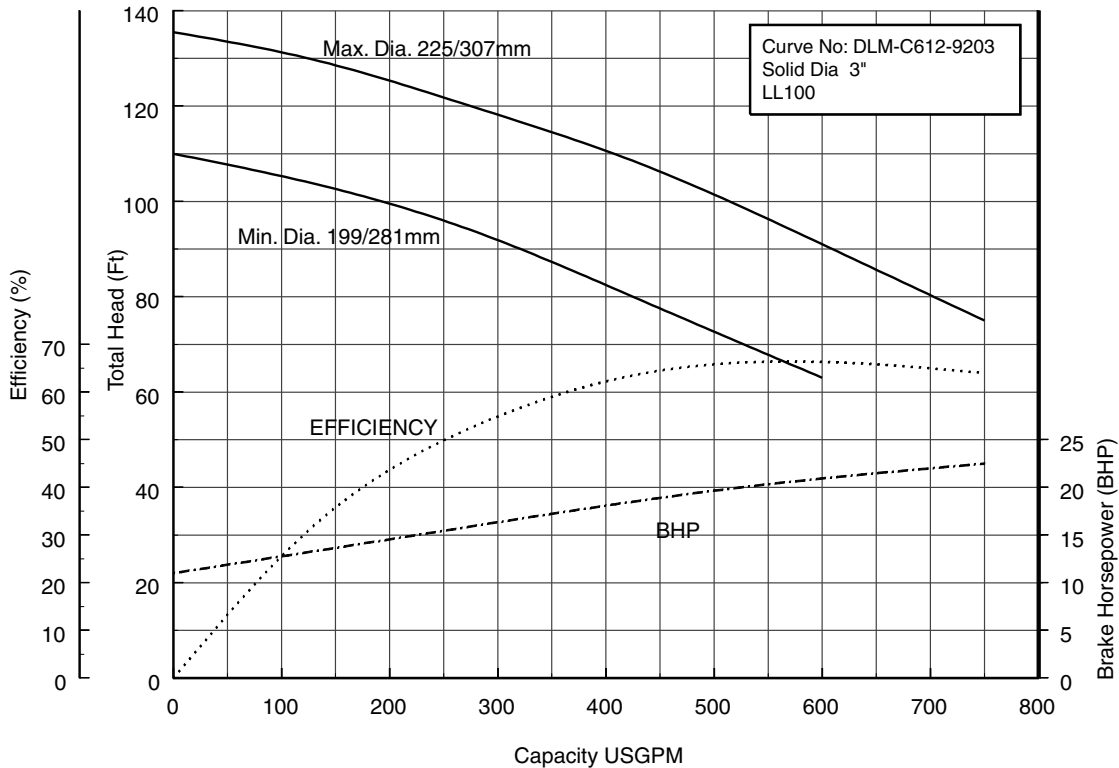

Performance Curves

Project: _____ GPM: _____ TDH: _____ EFF: _____ HP: _____ Chk'd: _____ Date: _____

100DLF618 (25HP) Synchronous Speed: 1800 RPM

4, 6 inch Discharge

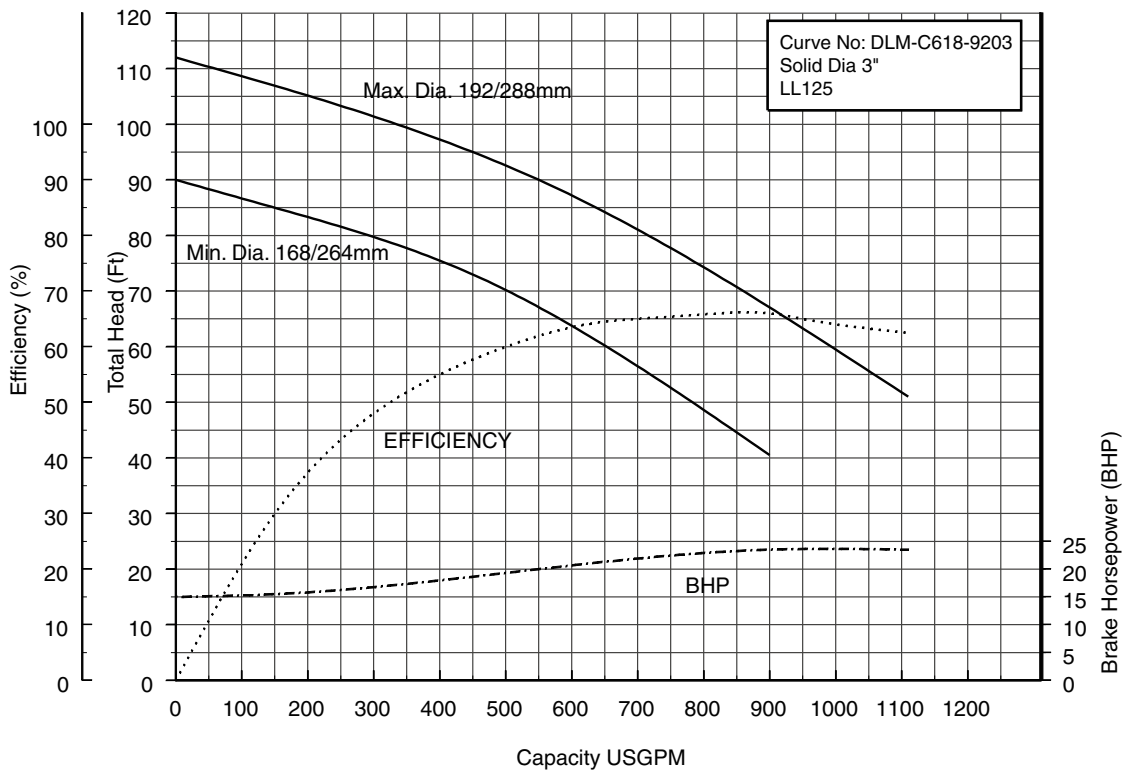

100DLMF622 (30HP) Synchronous Speed: 1800 RPM

3, 4 inch Discharge

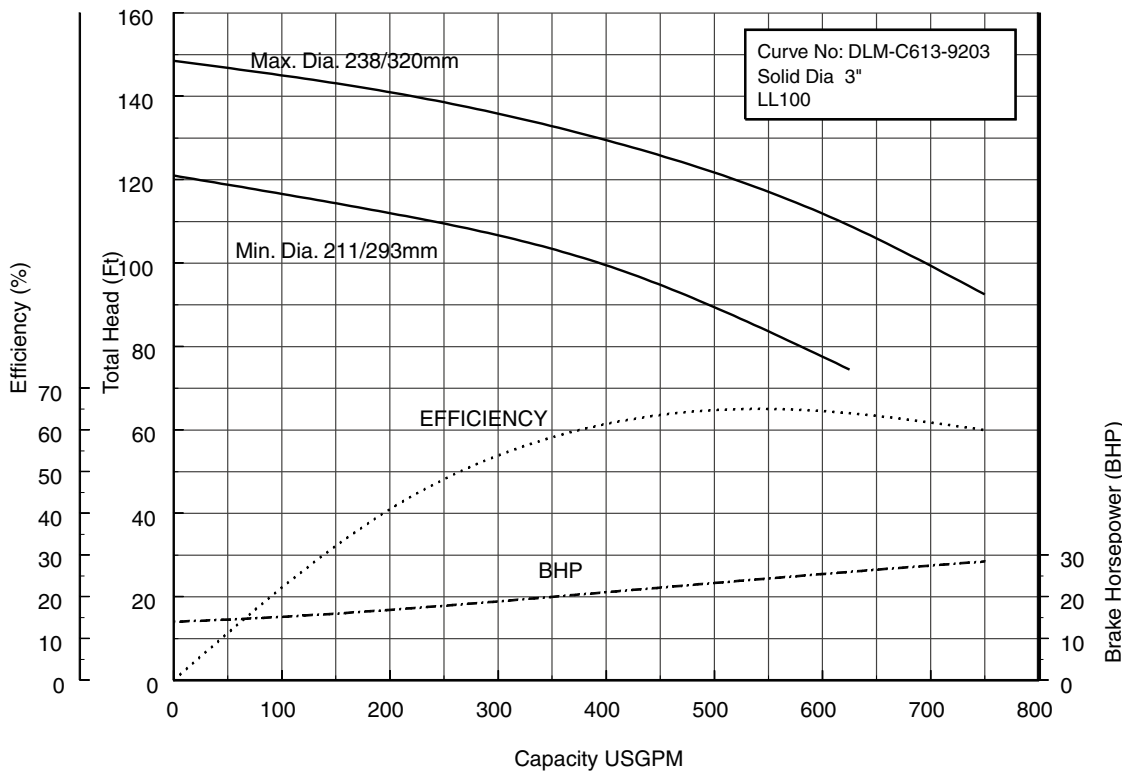

Performance Curves

Project: _____ GPM: _____ TDH: _____ EFF: _____ HP: _____ Chk'd: _____ Date: _____

100DLF622 (30HP) Synchronous Speed: 1800 RPM

4, 6 inch Discharge

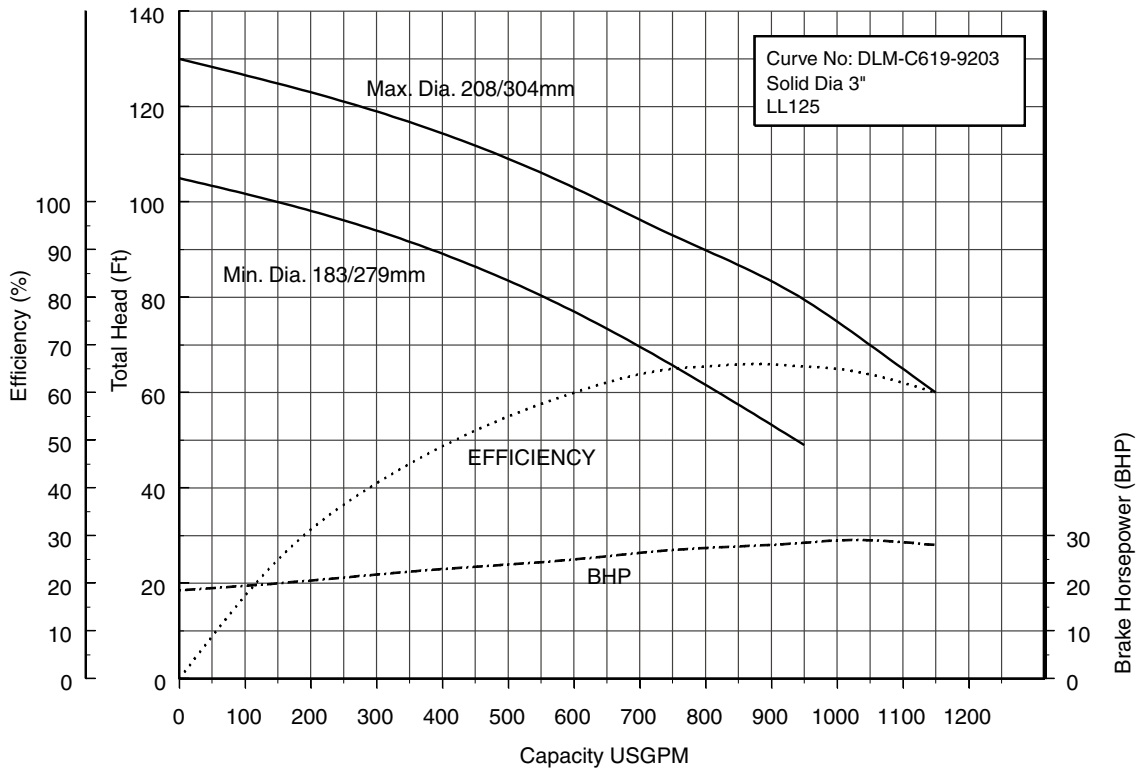

100DLF630 to 645 (40-60HP) Synchronous Speed: 1800 RPM

3, 4 inch Discharge

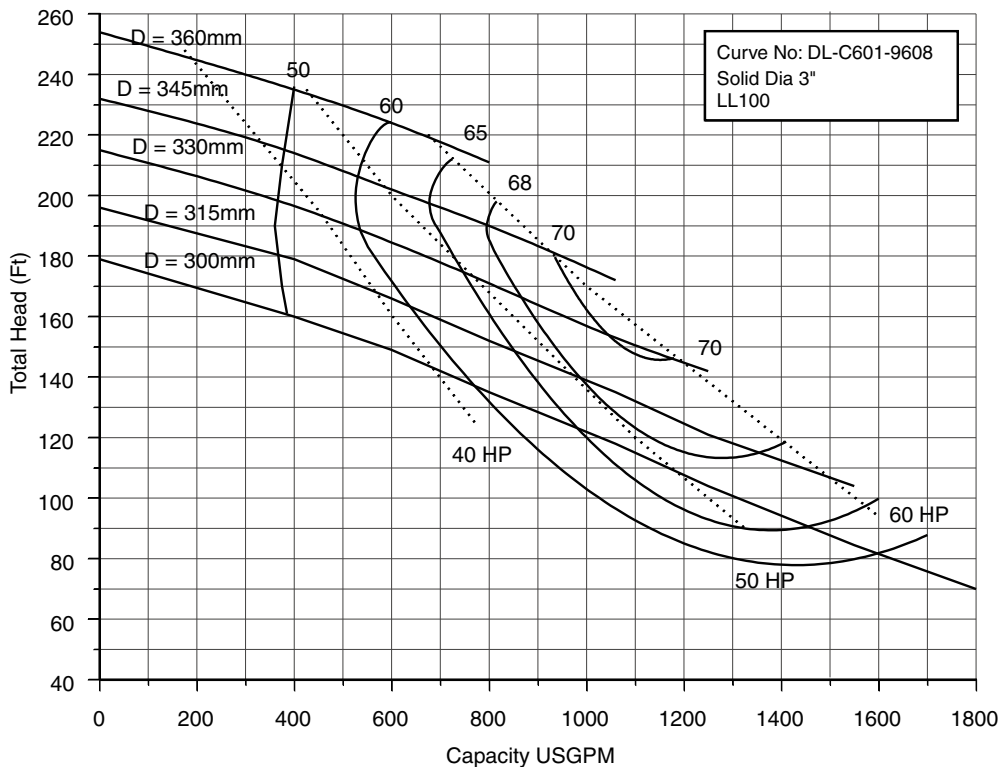

Performance Curves

Project: _____ GPM: _____ TDH: _____ EFF: _____ HP: _____ Chk'd: _____ Date: _____

150DLF67.5 200DLF67.5 (10HP) Synchronous Speed: 1800 RPM

6, 8 inch Discharge

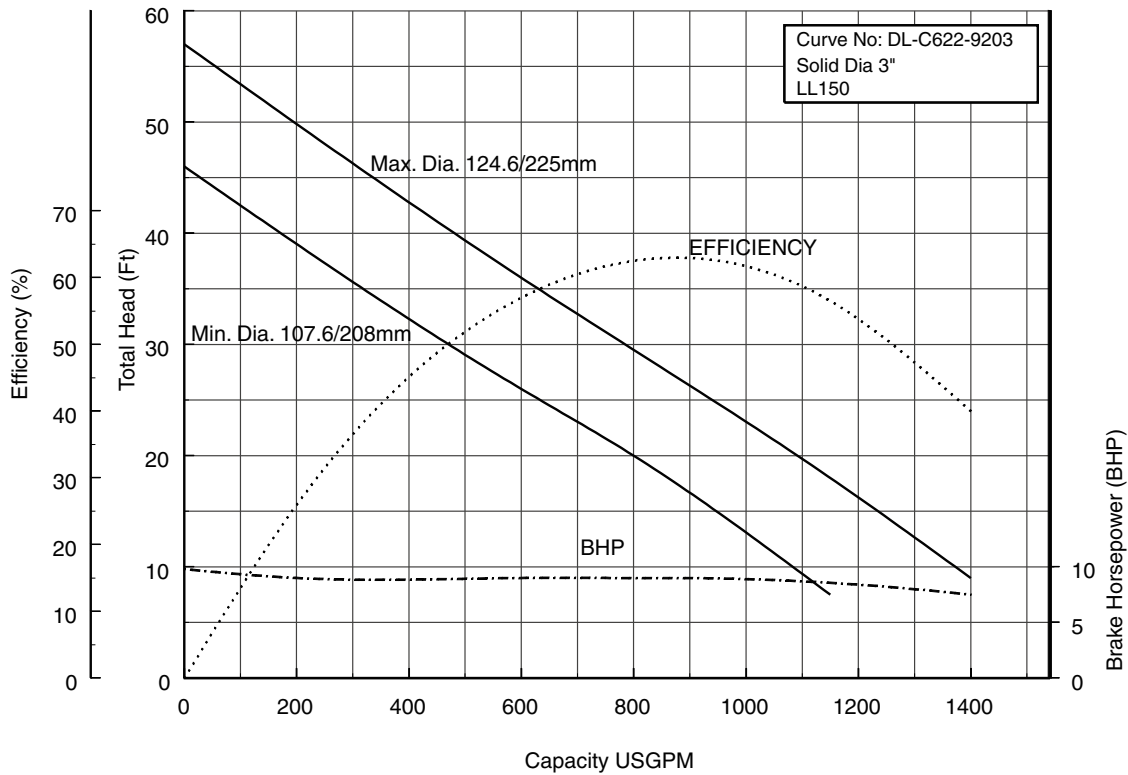

150DLF611 200DLF611 (15HP) Synchronous Speed: 1800 RPM

6, 8 inch Discharge

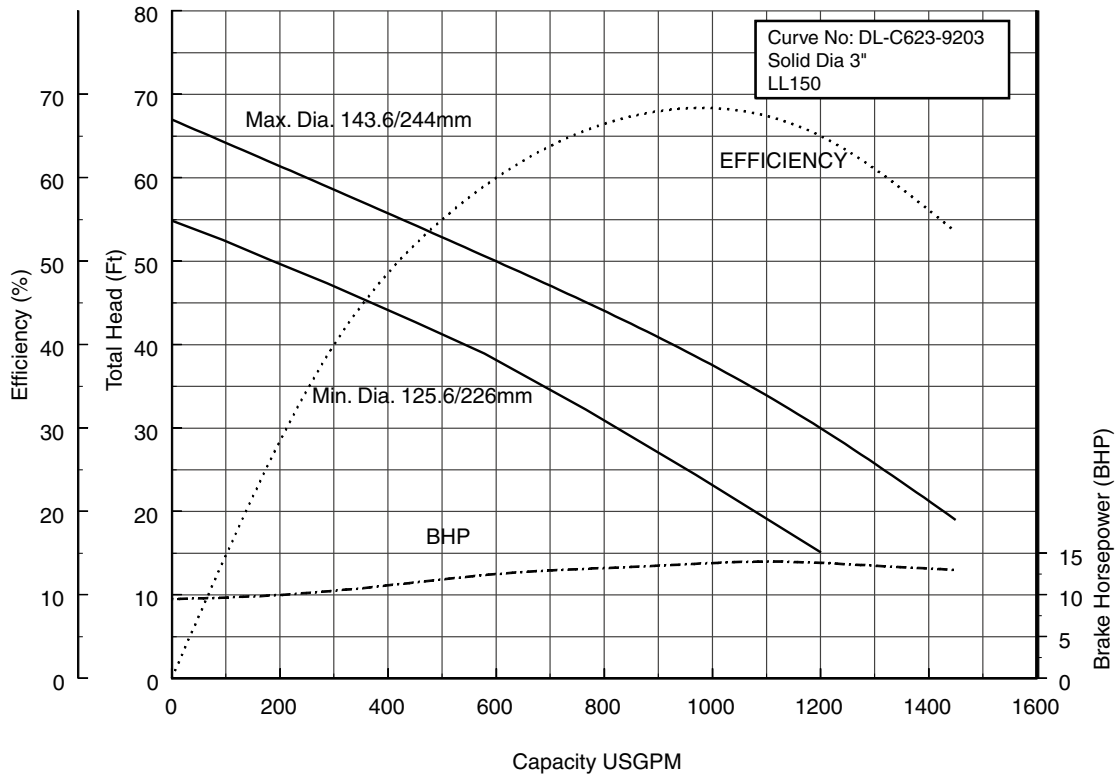

Performance Curves

Project: _____ GPM: _____ TDH: _____ EFF: _____ HP: _____ Chk'd: _____ Date: _____

150DLF615 200DLF615 (20HP) Synchronous Speed: 1800 RPM

6, 8 inch Discharge

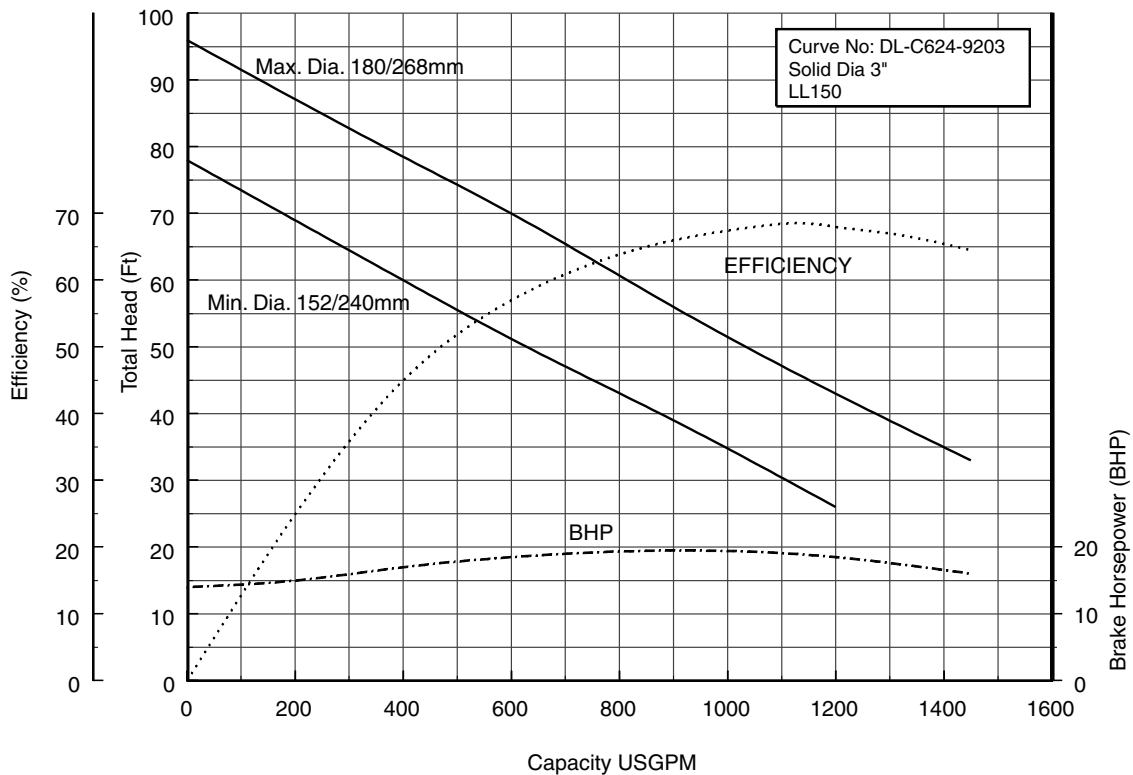

150DLF618 200DLF618 (25HP) Synchronous Speed: 1800 RPM

6, 8 inch Discharge

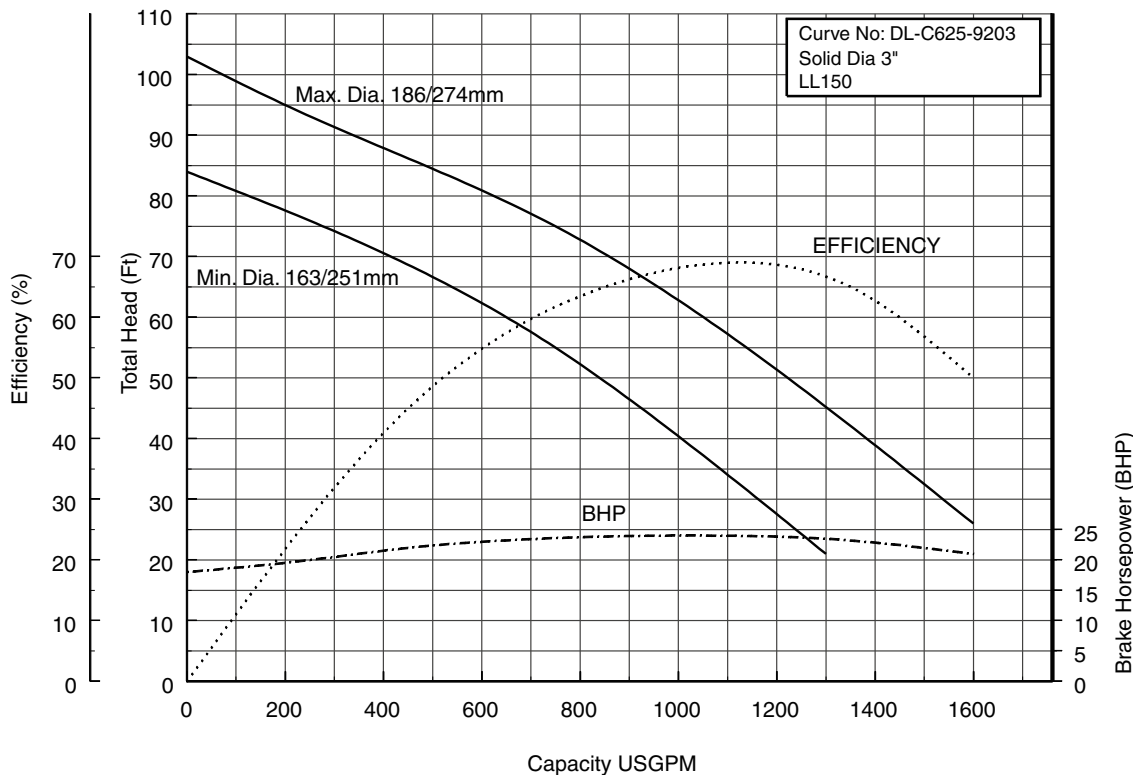

Performance Curves

Project: _____ GPM: _____ TDH: _____ EFF: _____ HP: _____ Chk'd: _____ Date: _____

150DLF622 200DLF622 (30HP) Synchronous Speed: 1800 RPM

6,8 inch Discharge

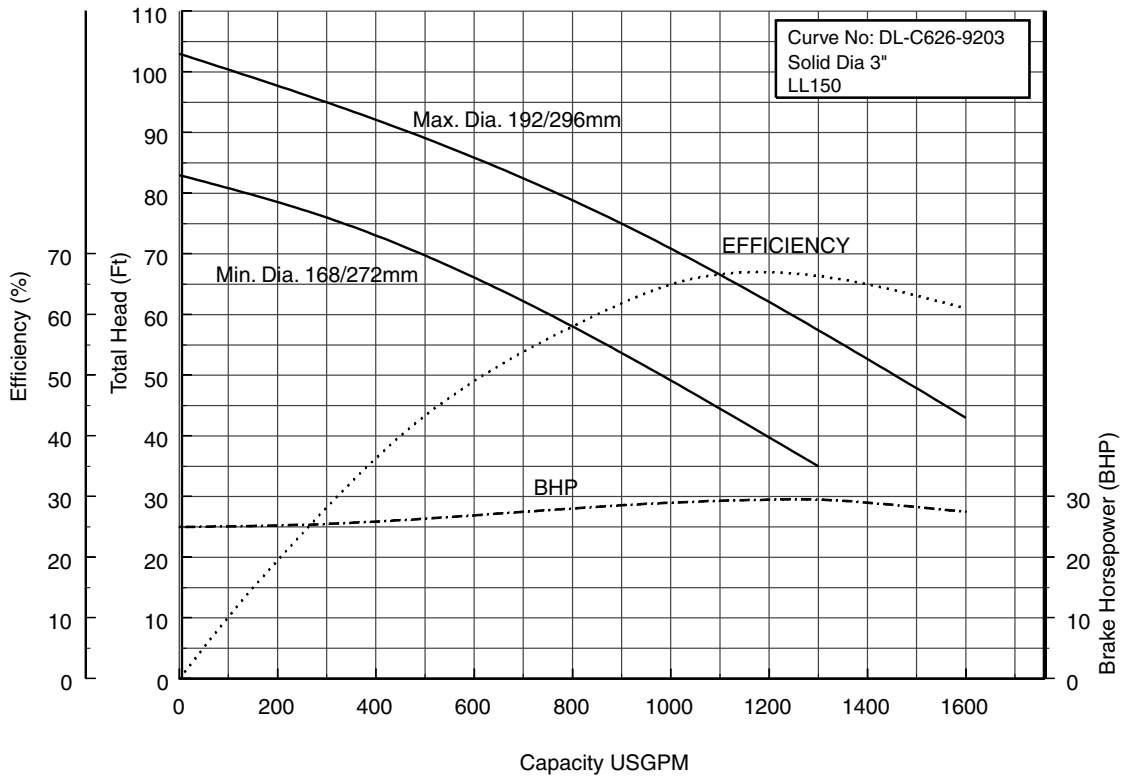

150DLF630 (40HP) Synchronous Speed: 1800 RPM

6 inch Discharge

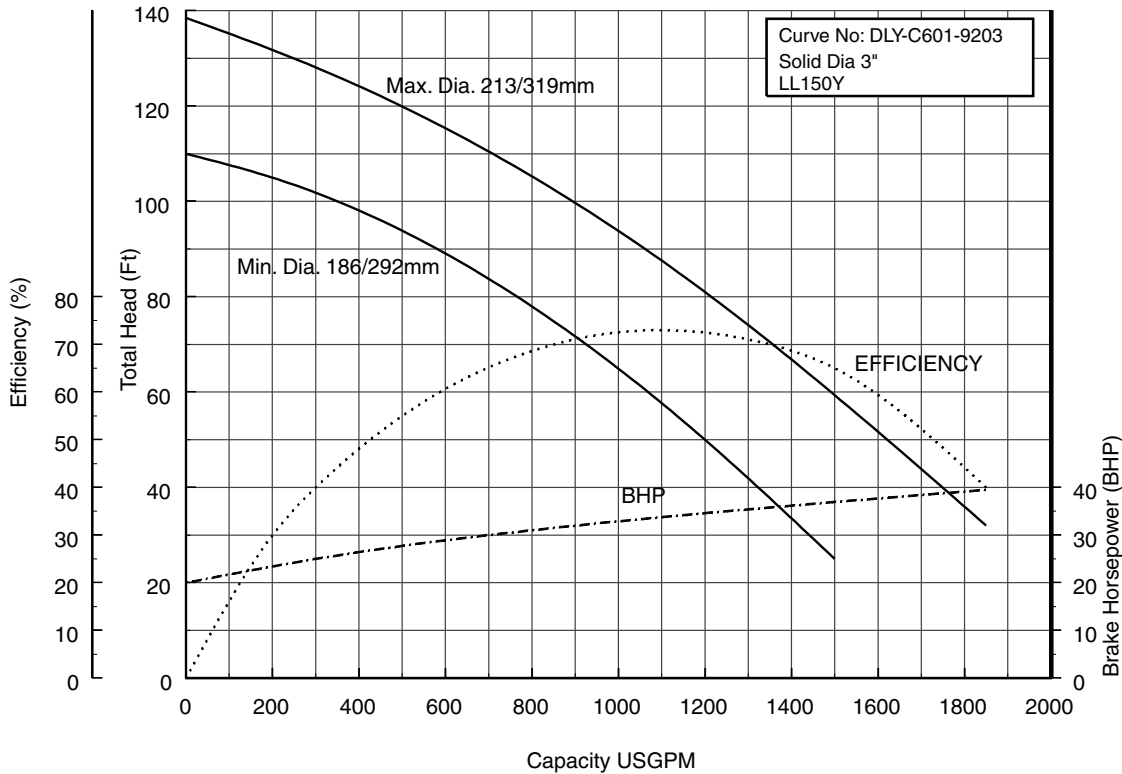

Performance Curves

Project: _____ GPM: _____ TDH: _____ EFF: _____ HP: _____ Chk'd: _____ Date: _____

150DLF637 (50HP) Synchronous Speed: 1800 RPM

6 inch Discharge

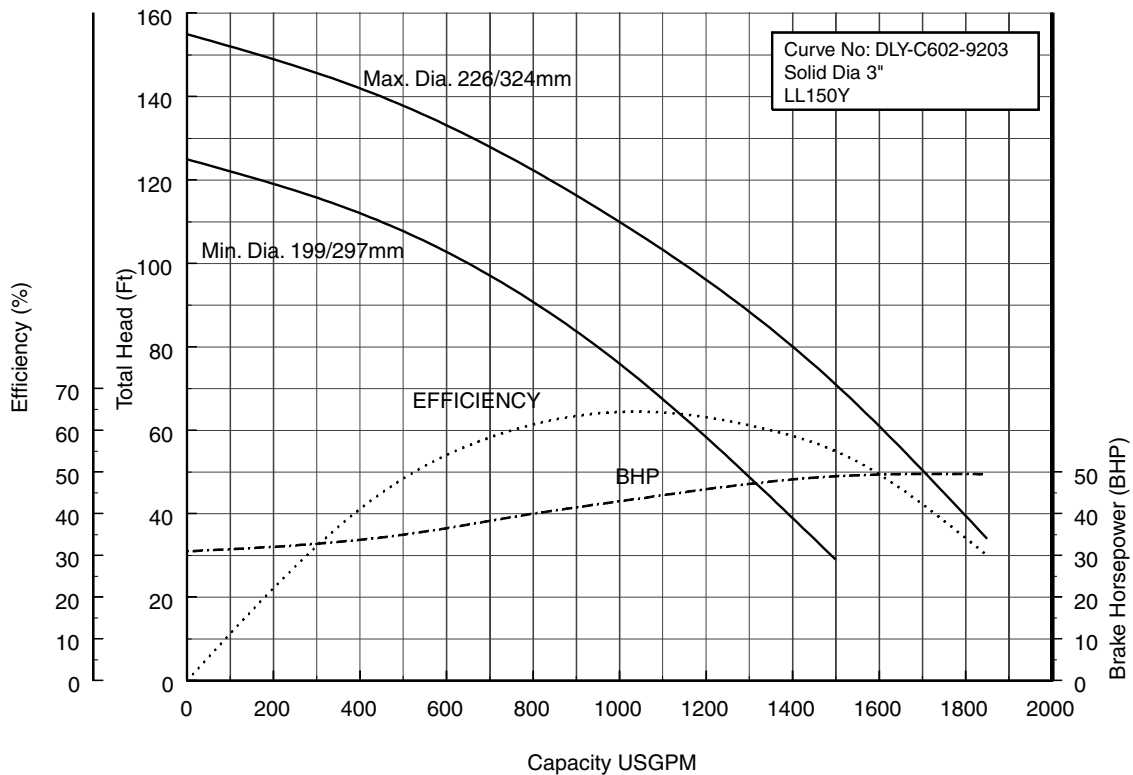

150DLF645 (60HP) Synchronous Speed: 1800 RPM

6 inch Discharge

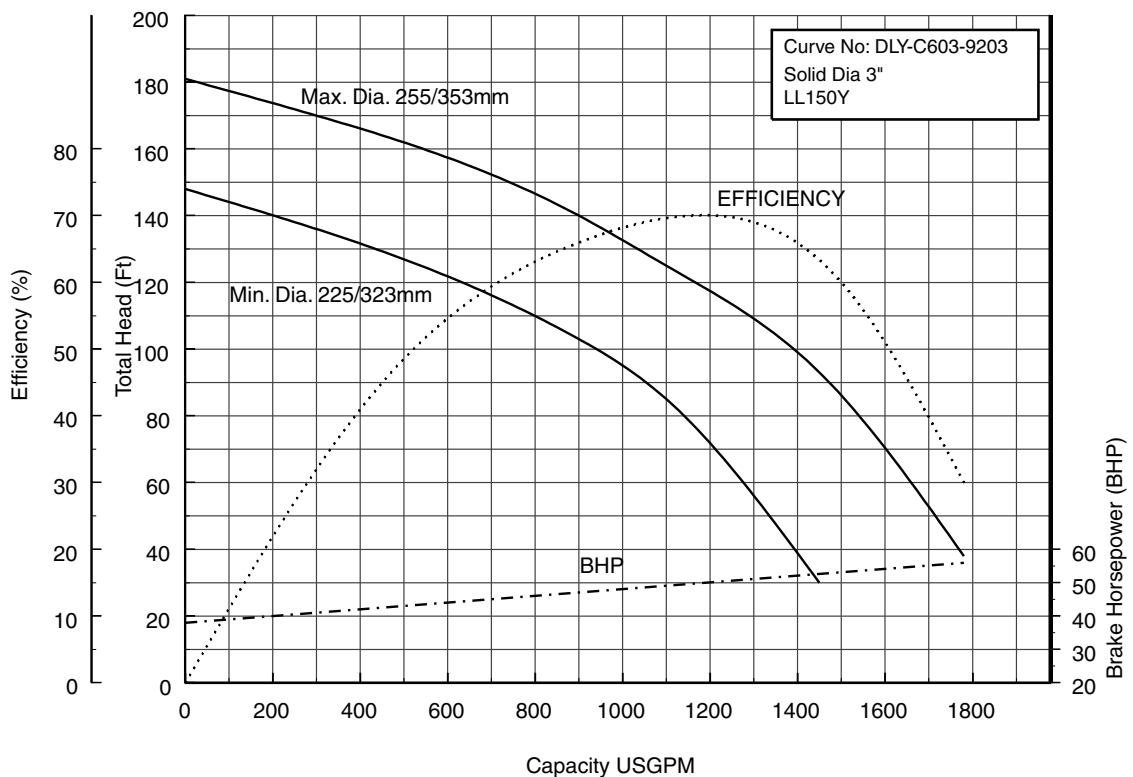

Performance Curves

Project: _____ GPM: _____ TDH: _____ EFF: _____ HP: _____ Chk'd: _____ Date: _____

200DLF630 (40HP) Synchronous Speed: 1800 RPM

8 inch Discharge

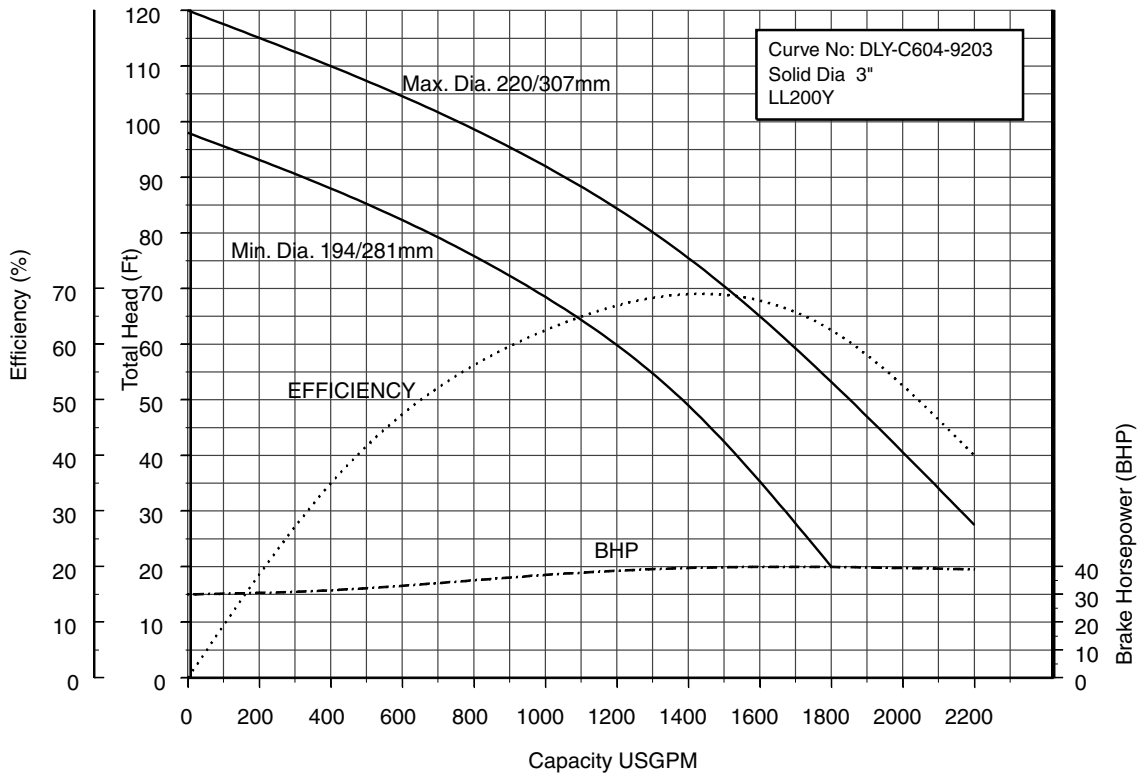

200DLF637 (50HP) Synchronous Speed: 1800 RPM

8 inch Discharge

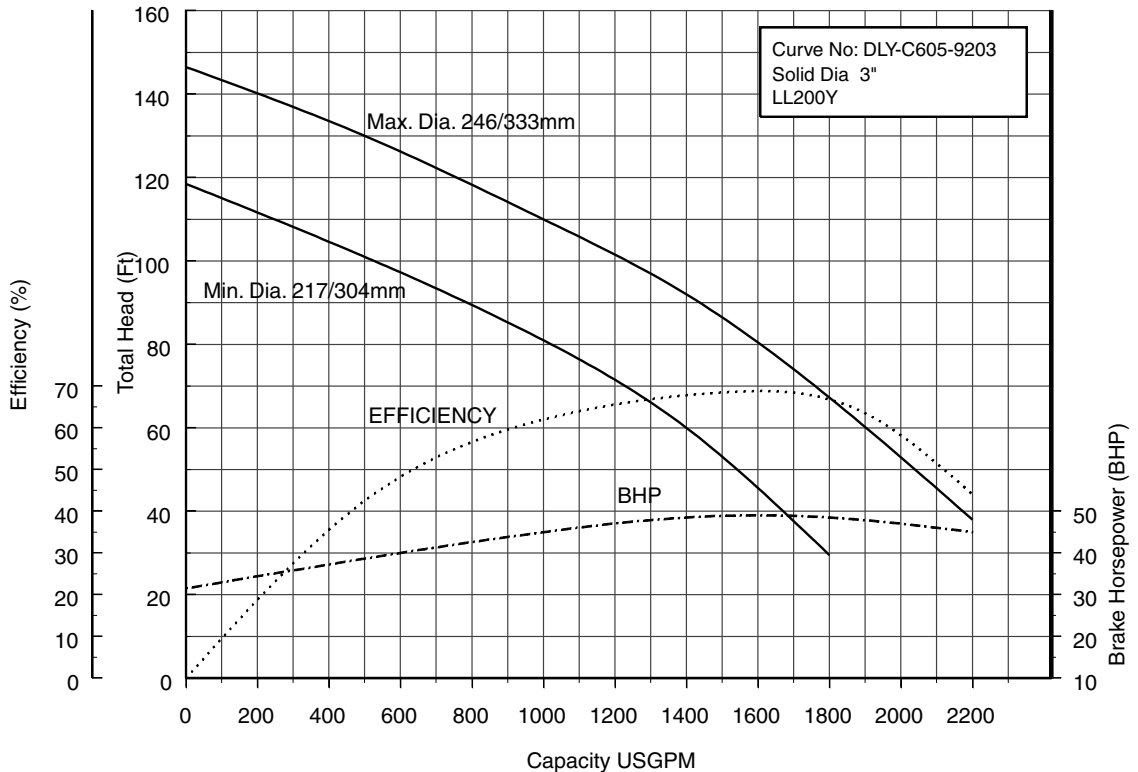

Performance Curves

Project: _____ GPM: _____ TDH: _____ EFF: _____ HP: _____ Chk'd: _____ Date: _____

200DLF645 (60HP) Synchronous Speed: 1800 RPM

8 inch Discharge

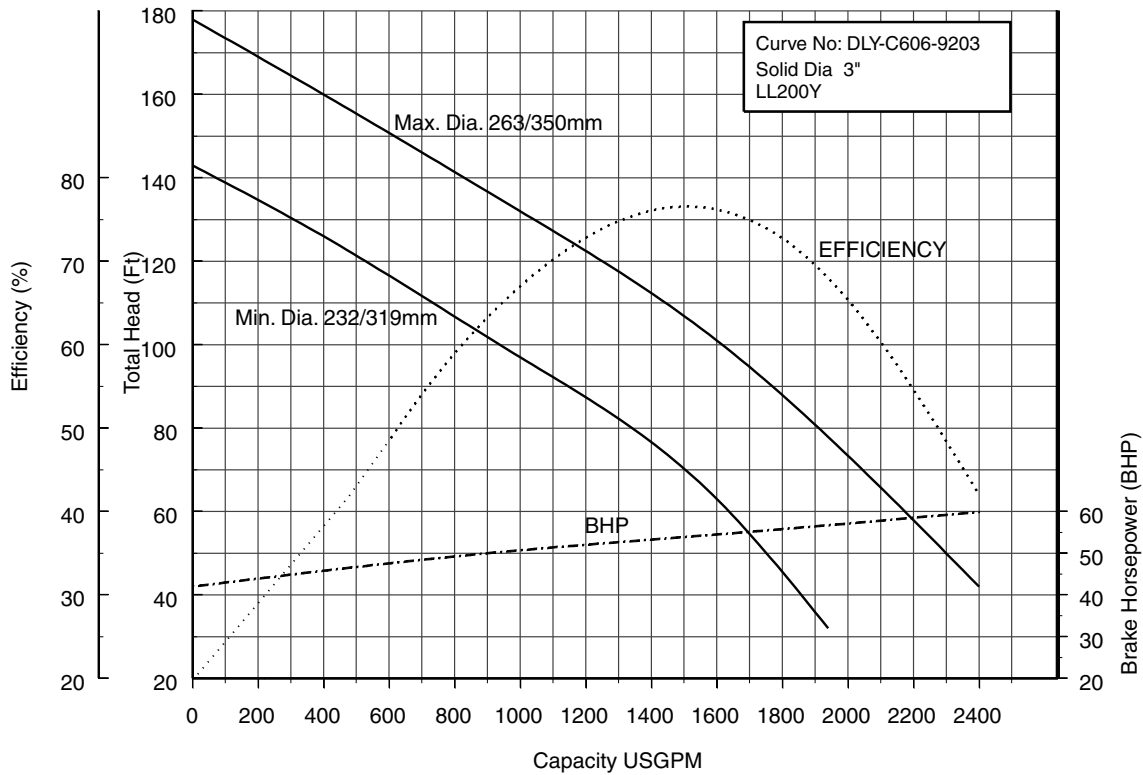

250DLF611 (15HP) Synchronous Speed: 1800 RPM

10 inch Discharge

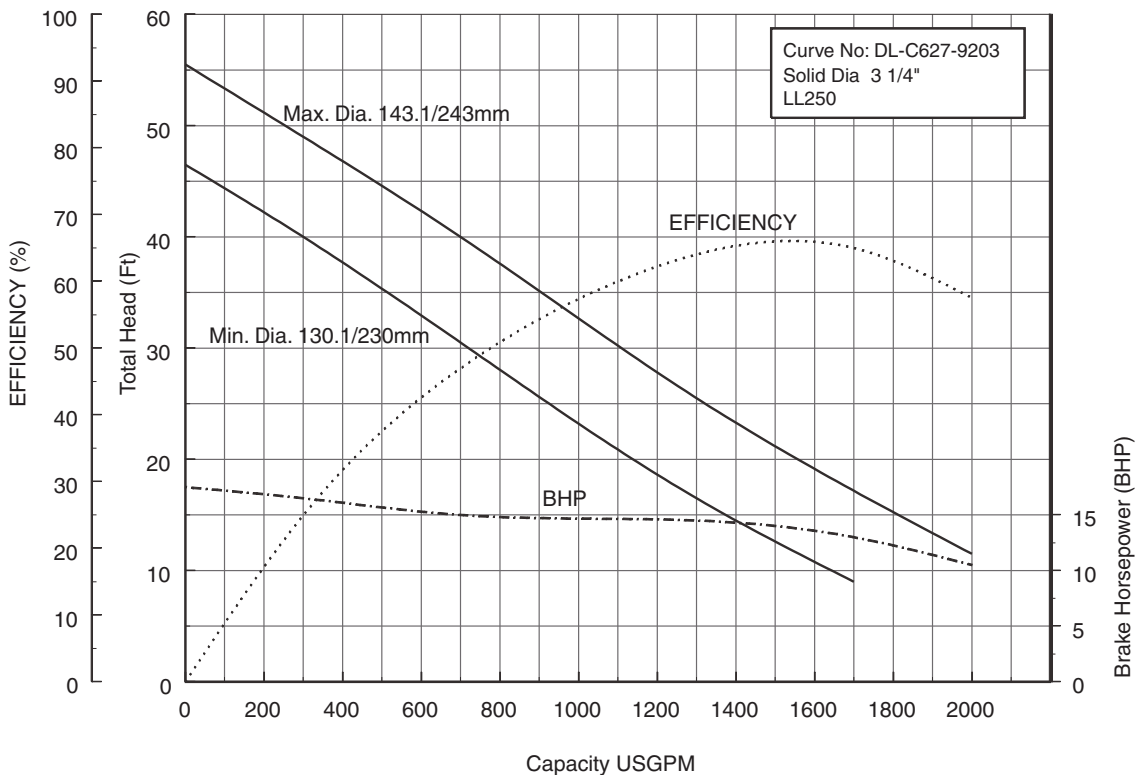

Performance Curves

Project: _____ GPM: _____ TDH: _____ EFF: _____ HP: _____ Chk'd: _____ Date: _____

250DLBF615 (20HP) Synchronous Speed: 1800 RPM

10 inch Discharge

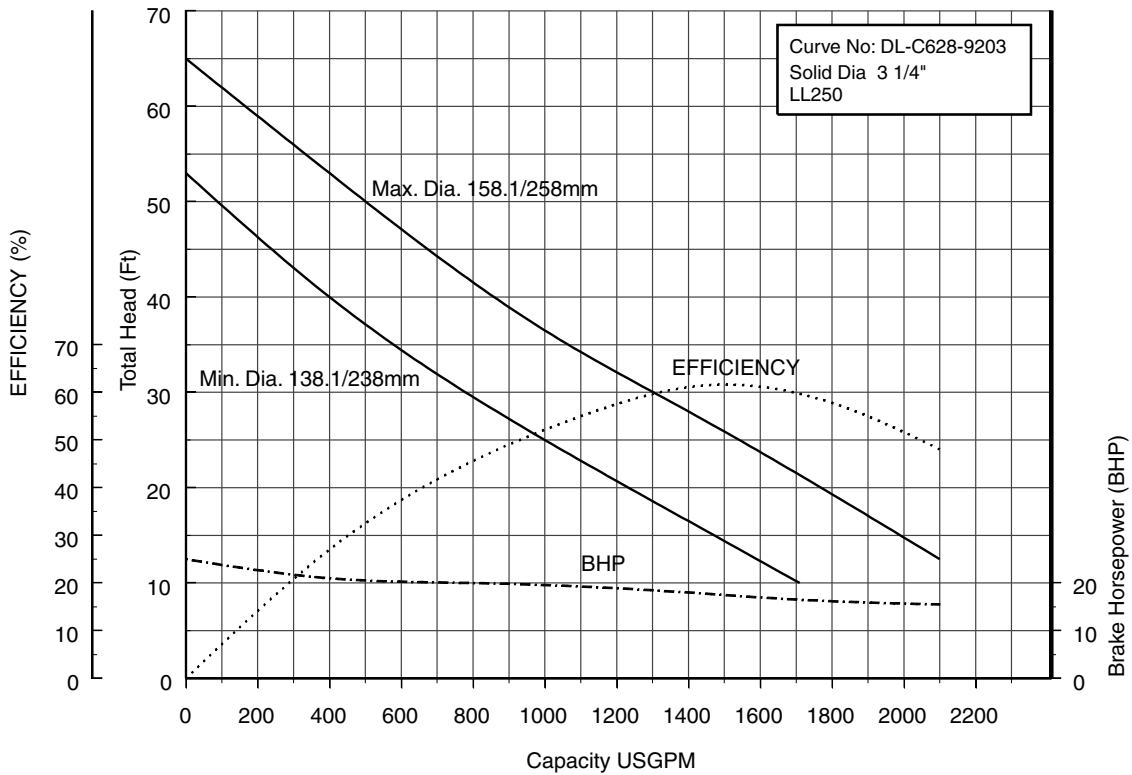

250DLCF615 (20HP) Synchronous Speed: 1800 RPM

10 inch Discharge

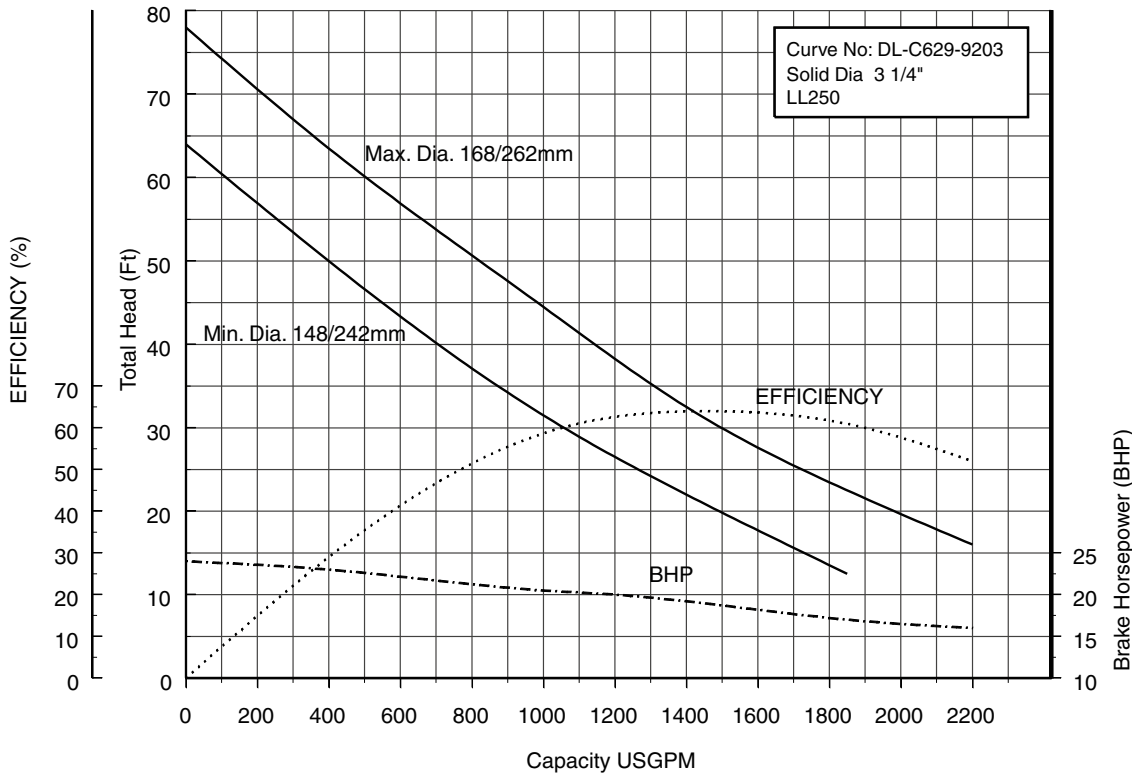

Performance Curves

Project: _____ GPM: _____ TDH: _____ EFF: _____ HP: _____ Chk'd: _____ Date: _____

250DLF618 (25HP) Synchronous Speed: 1800 RPM

10 inch Discharge

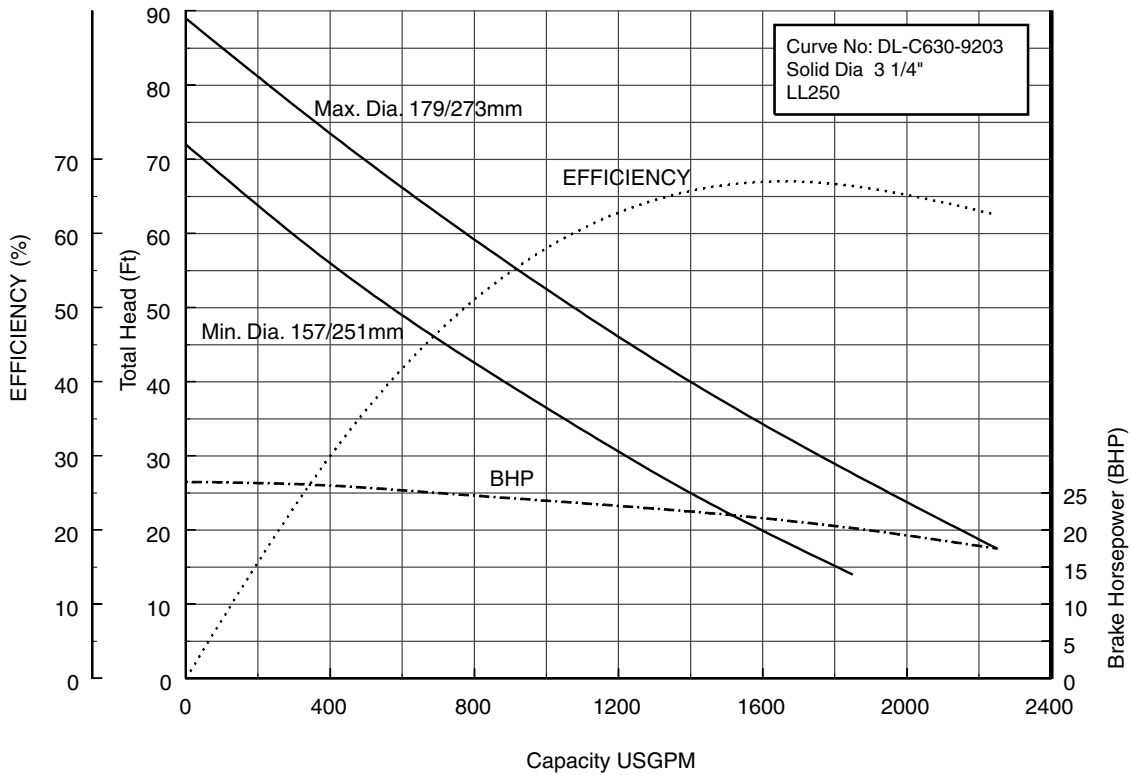

250DLF622 (30HP) Synchronous Speed: 1800 RPM

10 inch Discharge

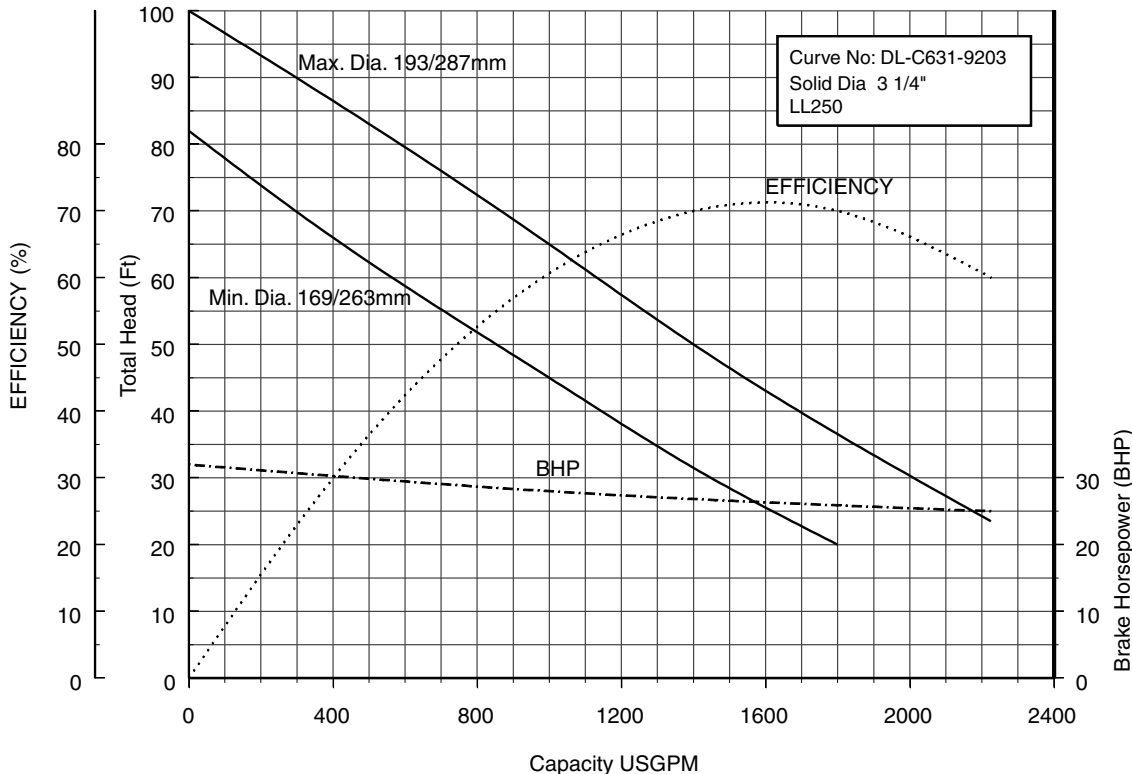

Performance Curves

Project: _____ GPM: _____ TDH: _____ EFF: _____ HP: _____ Chk'd: _____ Date: _____

250DLF630 (40HP) Synchronous Speed: 1800 RPM

10 inch Discharge

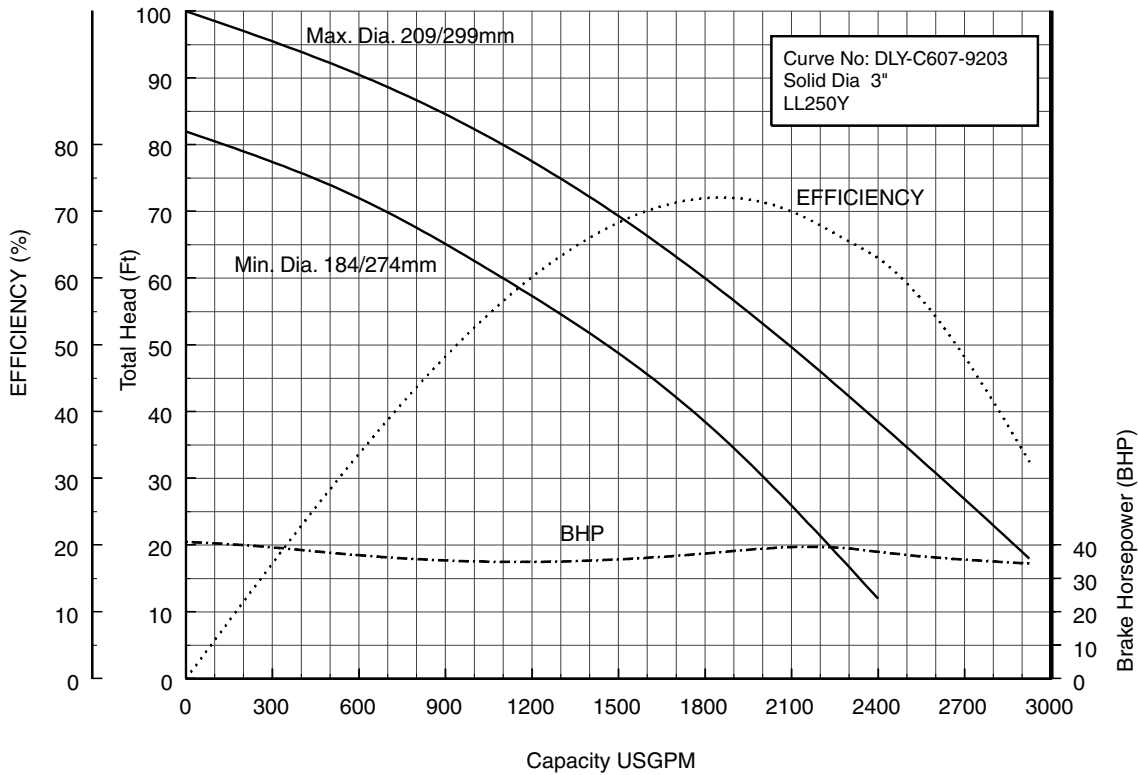

250DLF637 (50HP) Synchronous Speed: 1800 RPM

10 inch Discharge

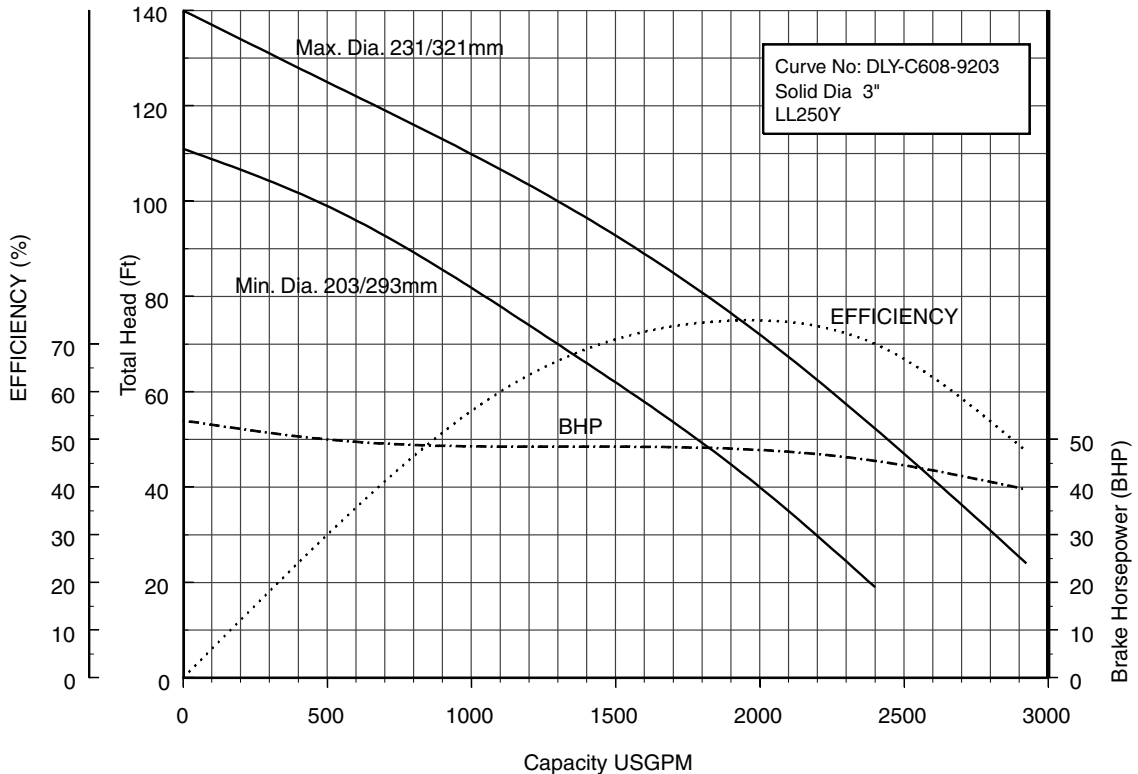

Performance Curves

Project: _____ GPM: _____ TDH: _____ EFF: _____ HP: _____ Chk'd: _____ Date: _____

250DLF645 (60HP) Synchronous Speed: 1800 RPM

10 inch Discharge

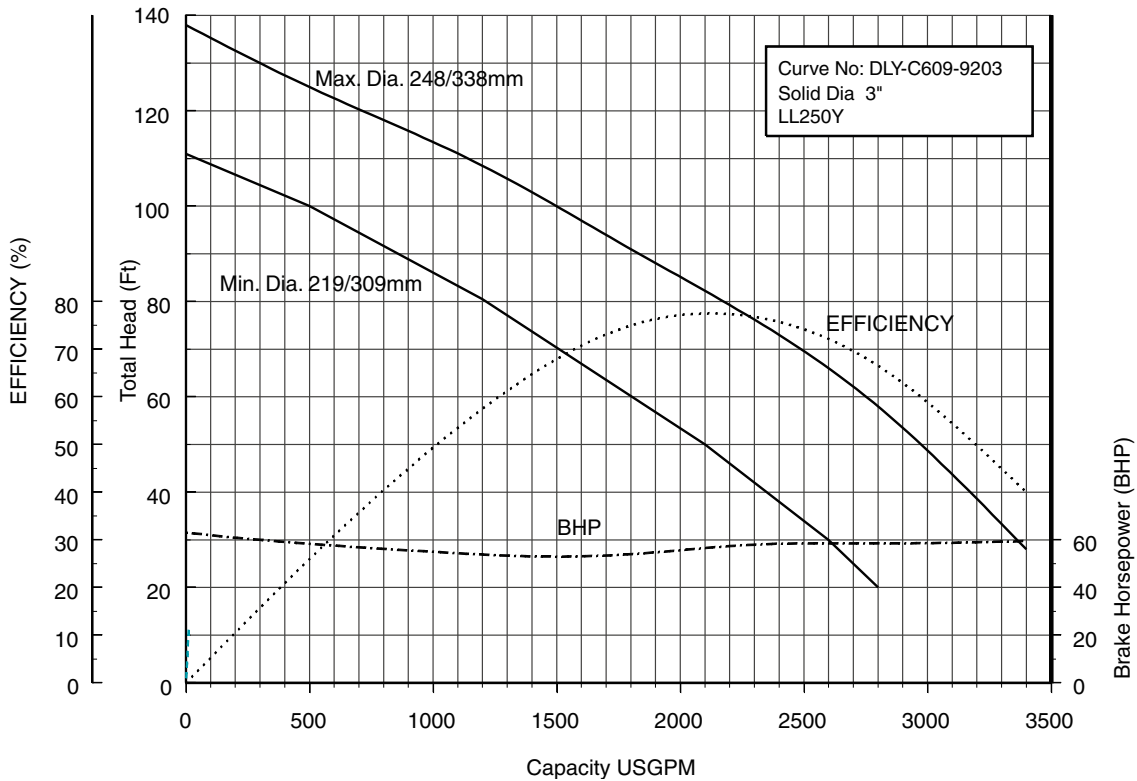

300DLF618 (25HP) Synchronous Speed: 1800 RPM

12 inch Discharge

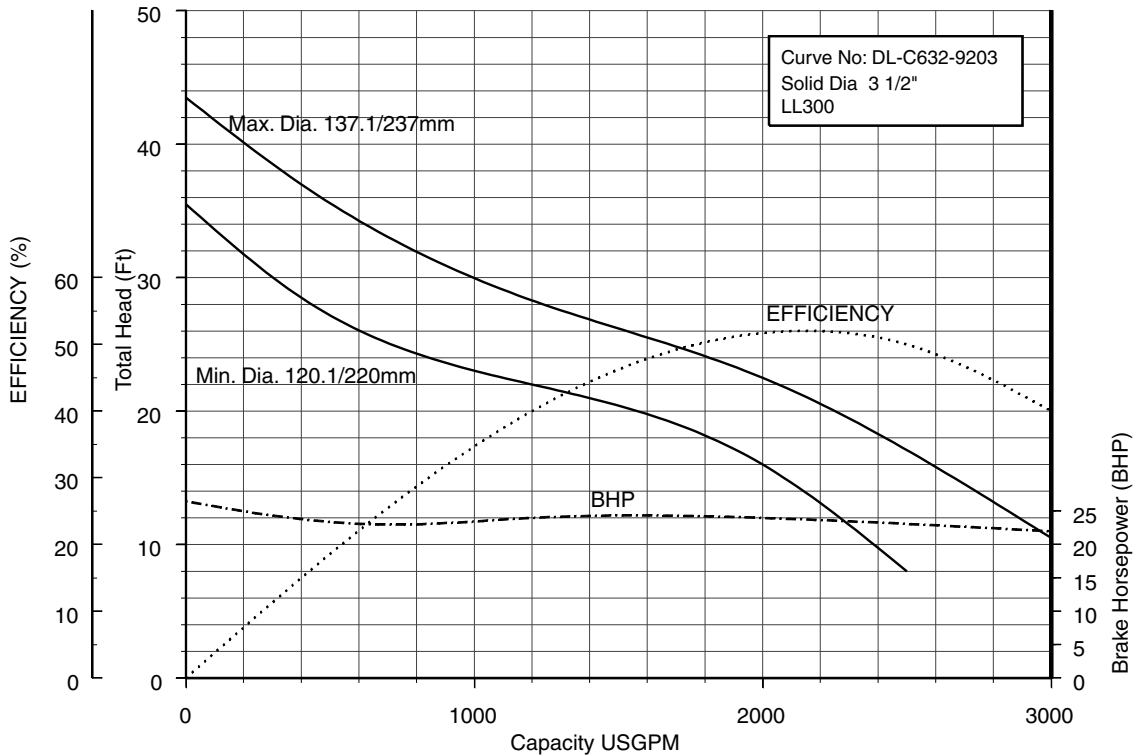

Performance Curves

Project: _____ GPM: _____ TDH: _____ EFF: _____ HP: _____ Chk'd: _____ Date: _____

300DLF622 (30HP) Synchronous Speed: 1800 RPM

12 inch Discharge

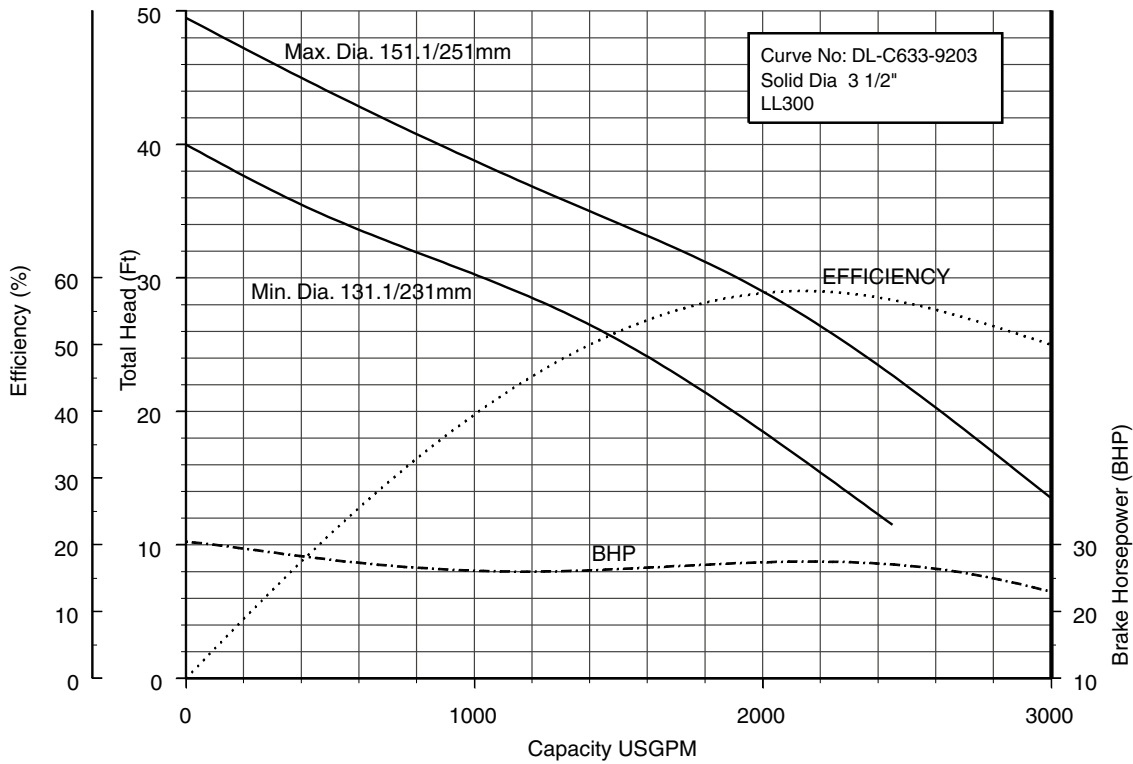

300DLF630 (40HP) Synchronous Speed: 1800 RPM

12 inch Discharge

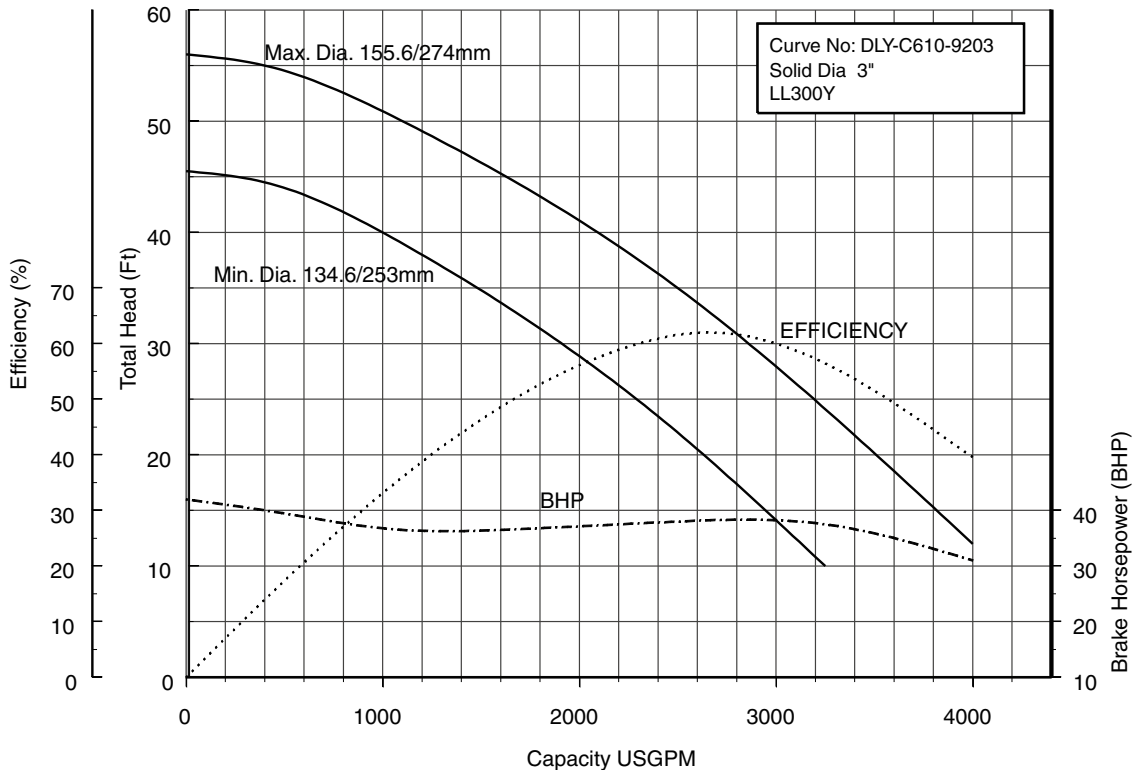

Performance Curves

Project: _____ GPM: _____ TDH: _____ EFF: _____ HP: _____ Chk'd: _____ Date: _____

300DLF637 (50HP) Synchronous Speed: 1800 RPM

12 inch Discharge

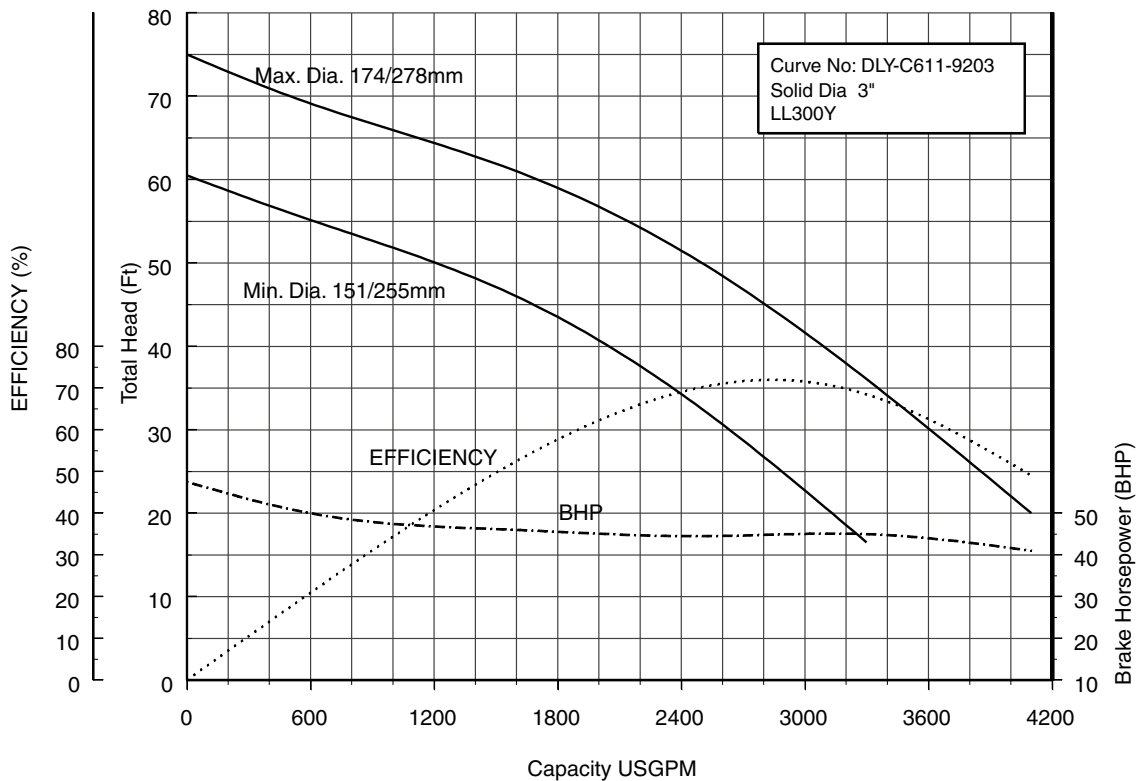

300DLF645 (60HP) Synchronous Speed: 1800 RPM

12 inch Discharge

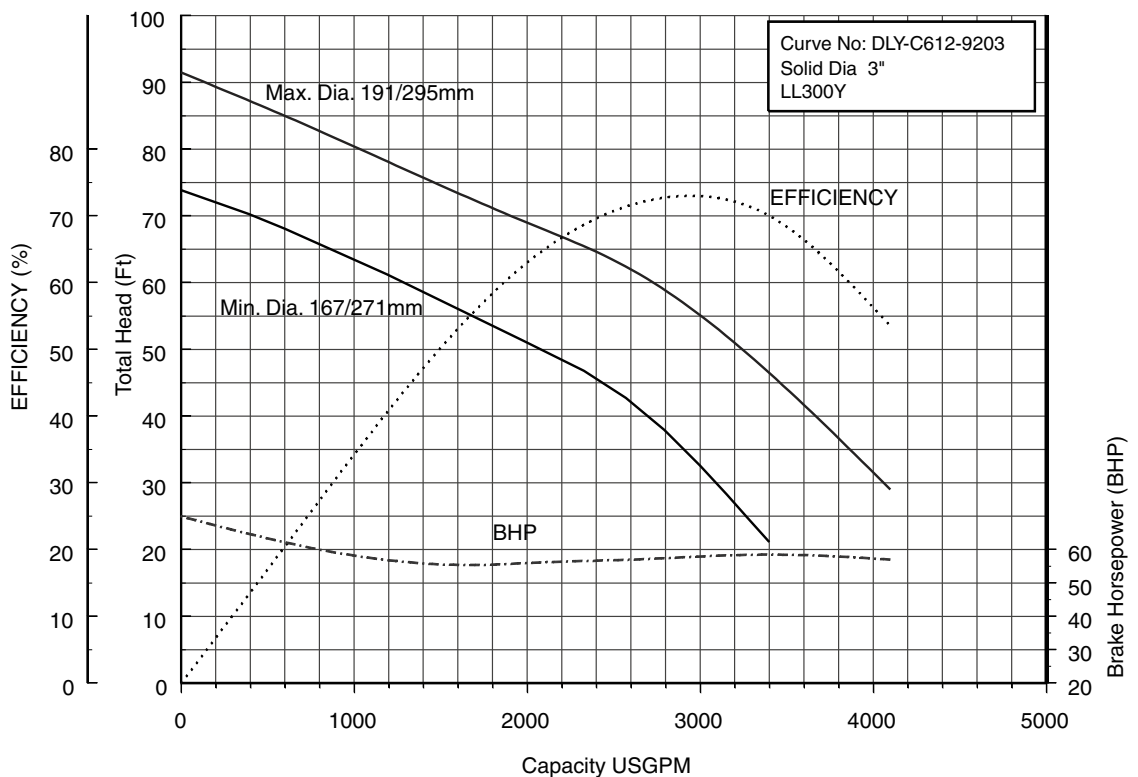

Dimensions

Project: _____ Model: _____ Chk'd: _____ Date: _____

Model DLFU
50DLFU, 2HP
80DLFU, 2 to 30HP

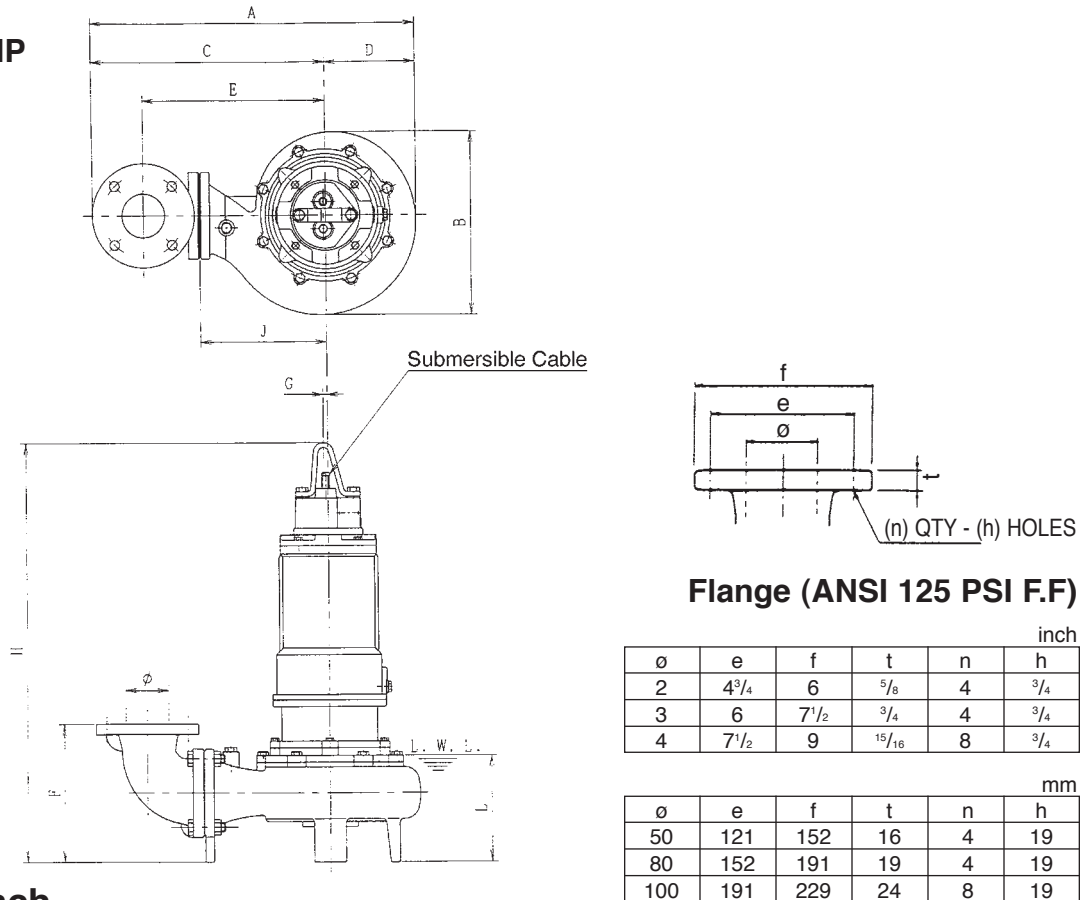

Dimensions: inch

PHASE	SIZE ø	MODEL	OUTPUT		PUMP & MOTOR										WEIGHT Lb
			KW	HP	A	B	C	D	E	F	G	H	J	L	
THREE	2/3	50DLFU61.5	1.5	2	17 ¹¹ / ₁₆	10 ¹ / ₈	12 ⁵ / ₈	5 ¹ / ₁₆	9 ⁵ / ₈	7 ⁷ / ₈	⁵ / ₁₆	27 ¹¹ / ₁₆	7 ¹ / ₁₆	6 ⁵ / ₁₆	132
		80DLFU61.5	1.5	2	20 ³ / ₄	11 ¹ / ₂	15	5 ³ / ₄	11 ¹ / ₄	8 ¹¹ / ₁₆	⁵ / ₁₆	28 ¹ / ₂	8 ³ / ₄	7 ¹ / ₁₆	148
		80DLFU62.2	2.2	3	23 ¹³ / ₁₆	13 ³ / ₁₆	17 ⁷ / ₁₆	6 ⁵ / ₈	13 ³ / ₈	9 ¹³ / ₁₆	⁵ / ₁₆	30 ¹ / ₄	9 ¹ / ₄	8 ¹ / ₁₆	209
		80DLFU63.7	3.7	5	23 ¹³ / ₁₆	13 ³ / ₁₆	17 ⁷ / ₁₆	6 ⁵ / ₈	13 ³ / ₈	9 ¹³ / ₁₆	⁵ / ₁₆	31 ¹³ / ₁₆	9 ¹ / ₄	8 ¹ / ₁₆	209
	3/4	80DLFU65.5	5.5	7 ¹ / ₂	23 ¹³ / ₁₆	13 ³ / ₁₆	17 ⁷ / ₁₆	6 ⁵ / ₈	13 ³ / ₈	9 ¹³ / ₁₆	³ / ₈	37 ¹ / ₈	9 ¹ / ₄	11	317
		80DLFU67.5	7.5	10	25 ¹ / ₁₆	14 ¹ / ₂	17 ³ / ₄	7 ⁵ / ₁₆	14	12 ¹¹ / ₁₆	³ / ₈	36 ¹ / ₁₆	9 ¹³ / ₁₆	10 ¹ / ₄	344
		80DLFU611	11	15	26 ¹ / ₈	15 ⁵ / ₁₆	18 ⁹ / ₁₆	7 ⁵ / ₈	14 ³ / ₄	12 ¹¹ / ₁₆	⁵ / ₁₆	39 ⁹ / ₁₆	10 ⁵ / ₈	9 ¹³ / ₁₆	470
		80DLFU615	15	20	26 ¹ / ₈	15 ⁵ / ₁₆	18 ⁹ / ₁₆	7 ⁵ / ₈	14 ³ / ₄	12 ¹¹ / ₁₆	⁵ / ₁₆	42 ⁵ / ₁₆	10 ⁵ / ₈	10 ¹³ / ₁₆	564
		80DLFU618	18.5	25	27 ¹ / ₄	15 ¹³ / ₁₆	19 ⁵ / ₁₆	7 ¹⁵ / ₁₆	15 ⁵ / ₁₆	12 ¹¹ / ₁₆	⁵ / ₁₆	43 ⁷ / ₈	11 ⁷ / ₁₆	10 ¹³ / ₁₆	639
		80DLFU622	22	30	27 ¹ / ₄	15 ¹³ / ₁₆	19 ⁵ / ₁₆	7 ¹⁵ / ₁₆	15 ⁵ / ₁₆	12 ¹¹ / ₁₆	⁵ / ₁₆	43 ⁷ / ₈	11 ⁷ / ₁₆	10 ¹³ / ₁₆	694

Dimensions: mm

PHASE	SIZE ø	MODEL	OUTPUT		PUMP & MOTOR										WEIGHT kg
			KW	HP	A	B	C	D	E	F	G	H	J	L	
THREE	50/80	50DLFU61.5	1.5	2	450	257	321	129	245	200	8	703	180	160	60
		80DLFU61.5	1.5	2	527	292	381	146	285	220	8	724	210	180	67
		80DLFU62.2	2.2	3	605	335	436	169	340	250	8	768	235	205	95
		80DLFU63.7	3.7	5	605	335	436	169	340	250	8	808	235	205	95
	80/100	80DLFU65.5	5.5	7 ¹ / ₂	605	335	436	169	340	250	10	943	235	280	144
		80DLFU67.5	7.5	10	636	369	451	186	355	323	10	916	250	260	156
		80DLFU611	11	15	664	385	471	193	375	323	8	1005	270	250	213
		80DLFU615	15	20	664	385	471	193	375	323	8	1075	270	275	256
		80DLFU618	18.5	25	692	402	491	202	395	323	8	1115	290	275	290
		80DLFU622	22	30	692	402	491	202	395	323	8	1115	290	275	315

***Note:** All 80DLFU dimensions are based on 3" discharge.

Dimensions

Project: _____ Model: _____ Chk'd: _____ Date: _____

Model DLMFU
80DLMFU, 2 to 7½HP
80DLCMFU, 10 to 15HP

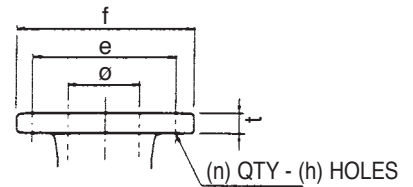
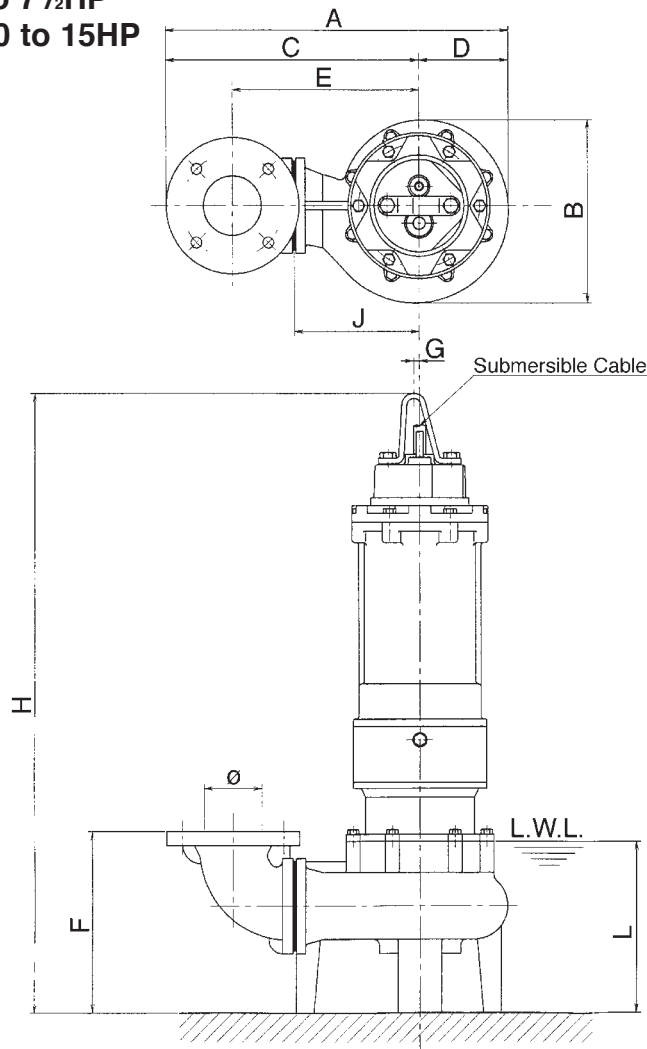

Flange (ANSI 125 PSI F.F)

inch					
ø	e	f	t	n	h
3	6	7½	¾	4	¾
4	7½	9	15/16	8	¾

mm					
ø	e	f	t	n	h
80	152	191	19	4	19
100	191	229	24	8	19

Dimensions: inch

PHASE	SIZE ø	MODEL	OUTPUT		PUMP & MOTOR										WEIGHT Lb
			KW	HP	A	B	C	D	E	F	G	H	J	L	
THREE	3/4	80DLMFU61.5	1.5	2	20¾	11½	15	5¾	11¼	8¹¹/₁₆	⁵/₁₆	28½	8¼	7¹/₁₆	157
		80DLMFU62.2	2.2	3	20¾	11½	15	5¾	11¼	8¹¹/₁₆	⁵/₁₆	29½	8¼	7½	187
		80DLMFU63.7	3.7	5	21⁷/₁₆	12⁵/₈	15³/₈	6¹/₁₆	11⁵/₈	8¹¹/₁₆	⁵/₁₆	31¹/₁₆	8¹¹/₁₆	7½	205
		80DLMFU65.5	5.5	7½	22⁷/₁₆	12¹⁵/₁₆	16	6⁷/₁₆	12²/₁₆	8¹¹/₁₆	³/₈	36³/₈	9¼	10¼	311
		80DLCMFU67.5	7.5	10	26³/₈	14¹⁵/₁₆	18⁷/₈	7½	13³/₁₆	12¹/₁₆	³/₈	35⁵/₈	10¼	9¹/₁₆	375
		80DLCMFU611	11	15	27⁹/₁₆	15¹¹/₁₆	19¹¹/₁₆	7⁷/₈	14	12	⁵/₁₆	39⁵/₁₆	11	9¹/₁₆	500

Dimensions: mm

PHASE	SIZE ø	MODEL	OUTPUT		PUMP & MOTOR										WEIGHT kg
			KW	HP	A	B	C	D	E	F	G	H	J	L	
THREE	80/100	80DLMFU61.5	1.5	2	527	292	381	146	285	220	8	724	210	180	71
		80DLMFU62.2	2.2	3	527	292	381	146	285	220	8	750	210	190	85
		80DLMFU63.7	3.7	5	545	308	391	154	295	220	8	789	220	190	93
		80DLMFU65.5	5.5	7½	570	328	406	164	310	220	10	924	235	261	141
		80DLCMFU67.5	7.5	10	670	379	480	190	335	307	10	905	260	240	170
		80DLCMFU611	11	15	700	399	500	200	355	305	8	998	280	240	227

***Note:** All dimensions are based on 3" discharge.

Dimensions

Project: _____ Model: _____ Chk'd: _____ Date: _____

Model DLFU
100DLFU, 2 to 60HP

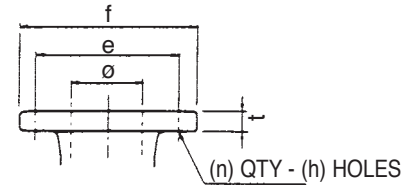
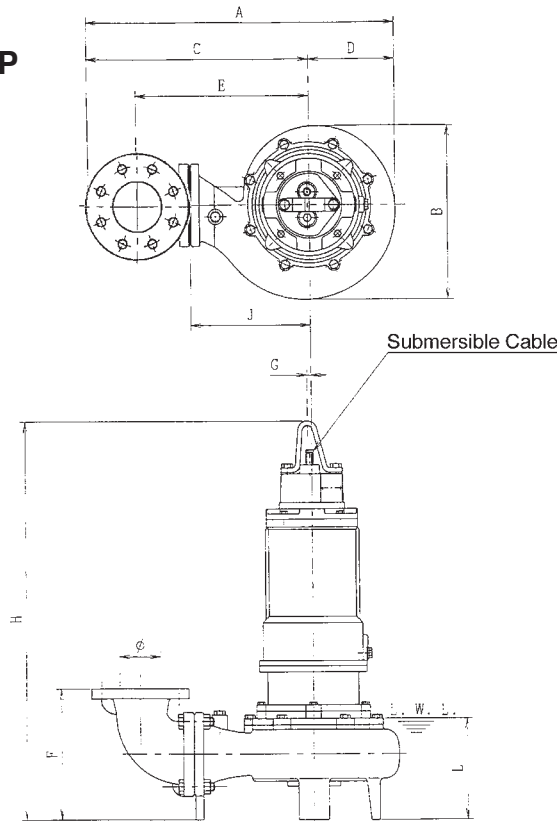

Flange (ANSI 125 PSI F.F)

inch					
ø	e	f	t	n	h
3	6	7 ¹ / ₂	³ / ₄	4	³ / ₄
4	7 ¹ / ₂	9	¹⁵ / ₁₆	8	³ / ₄
6	9 ¹ / ₂	11	1	8	⁷ / ₈

mm					
ø	e	f	t	n	h
80	152	191	19	4	19
100	191	229	24	8	19
150	241	279	25	8	22

Dimensions: inch

PHASE	SIZE ø	MODEL	OUTPUT		PUMP & MOTOR										WEIGHT Lb
			kW	HP	A	B	C	D	E	F	G	H	J	L	
THREE	3/4	100DLFU61.5	1.5	2	21 ³ / ₄	10 ¹ / ₂	16 ⁹ / ₁₆	5 ¹ / ₄	12	10 ¹³ / ₁₆	⁵ / ₁₆	29 ¹⁵ / ₁₆	7 ⁷ / ₈	8 ¹¹ / ₁₆	170
		100DLFU62.2	2.2	3	22 ⁷ / ₈	11 ¹ / ₈	17 ⁹ / ₁₆	5 ⁹ / ₁₆	12 ¹³ / ₁₆	10 ¹³ / ₁₆	⁵ / ₁₆	30 ¹³ / ₁₆	8 ¹¹ / ₁₆	8 ¹¹ / ₁₆	198
		100DLFU63.7	3.7	5	22 ⁷ / ₈	11 ¹ / ₈	17 ⁹ / ₁₆	5 ⁹ / ₁₆	12 ¹³ / ₁₆	10 ¹³ / ₁₆	⁵ / ₁₆	32 ³ / ₈	8 ¹¹ / ₁₆	8 ¹¹ / ₁₆	216
	4/6	100DLFU65.5	5.5	7 ¹ / ₂	28 ⁹ / ₁₆	15 ¹¹ / ₁₆	20 ¹¹ / ₁₆	7 ⁷ / ₈	16 ¹ / ₈	15	³ / ₈	37 ⁷ / ₁₆	11	11 ⁷ / ₁₆	353
		100DLFU67.5	7.5	10	28 ⁹ / ₁₆	15 ¹¹ / ₁₆	20 ¹¹ / ₁₆	7 ⁷ / ₈	16 ¹ / ₈	15	³ / ₈	37 ⁷ / ₁₆	11	11 ⁷ / ₁₆	395
		100DLFU611	11	15	28 ⁹ / ₁₆	15 ¹¹ / ₁₆	20 ¹¹ / ₁₆	7 ⁷ / ₈	16 ¹ / ₈	15	⁵ / ₁₆	41 ¹ / ₈	11	11 ⁷ / ₁₆	476
		100DLFU615	15	20	29 ³ / ₄	16 ⁷ / ₁₆	21 ⁷ / ₁₆	8 ¹ / ₄	16 ¹⁵ / ₁₆	14 ¹³ / ₁₆	⁵ / ₁₆	43 ³ / ₄	11 ¹³ / ₁₆	11 ¹³ / ₁₆	602
		100DLFU618	18.5	25	30 ⁷ / ₈	17 ¹ / ₄	22 ¹ / ₄	8 ¹¹ / ₁₆	17 ¹¹ / ₁₆	14 ¹³ / ₁₆	⁵ / ₁₆	44 ¹³ / ₁₆	12 ⁵ / ₈	11 ¹³ / ₁₆	677
		100DLFU622	22	30	30 ⁷ / ₈	17 ¹ / ₄	22 ¹ / ₄	8 ¹¹ / ₁₆	17 ¹¹ / ₁₆	14 ¹³ / ₁₆	⁵ / ₁₆	44 ¹³ / ₁₆	12 ⁵ / ₈	11 ¹³ / ₁₆	736
	4	100DLFU630	30	40	33 ¹ / ₄	19 ⁹ / ₁₆	23 ⁵ / ₈	9 ⁵ / ₈	19 ¹ / ₈	19 ⁷ / ₁₆	⁵ / ₁₆	55 ³ / ₄	14 ³ / ₁₆	19 ⁹ / ₁₆	1001
		100DLFU637	37	50	33 ¹ / ₄	19 ⁹ / ₁₆	23 ⁵ / ₈	9 ⁵ / ₈	19 ¹ / ₈	19 ⁷ / ₁₆	⁵ / ₁₆	59 ⁵ / ₁₆	14 ³ / ₁₆	20 ⁵ / ₁₆	1171
		100DLFU645	45	60	33 ¹ / ₄	19 ⁹ / ₁₆	23 ⁵ / ₈	9 ⁵ / ₈	19 ¹ / ₈	19 ⁷ / ₁₆	⁵ / ₁₆	59 ⁵ / ₁₆	14 ³ / ₁₆	20 ⁵ / ₁₆	1219

Dimensions: mm

PHASE	SIZE ø	MODEL	OUTPUT		PUMP & MOTOR										WEIGHT kg
			kW	HP	A	B	C	D	E	F	G	H	J	L	
THREE	80/100	100DLFU61.5	1.5	2	553	267	420	134	305	275	8	760	200	220	77
		100DLFU62.2	2.2	3	581	282	440	141	325	275	8	782	220	220	90
		100DLFU63.7	3.7	5	581	282	440	141	325	275	8	822	220	220	98
	100/150	100DLFU65.5	5.5	7 ¹ / ₂	725	398	525	200	410	381	10	951	280	290	160
		100DLFU67.5	7.5	10	725	398	525	200	410	381	10	951	280	290	179
		100DLFU611	11	15	725	398	525	200	410	381	8	1044	280	290	216
		100DLFU615	15	20	755	417	545	210	430	377	8	1099	300	300	273
		100DLFU618	18.5	25	784	438	565	220	450	377	8	1139	320	300	307
		100DLFU622	22	30	784	438	565	220	450	377	8	1139	320	300	334
	100	100DLFU630	30	40	845	497	600	245	485	493	8	1416	360	490	454
		100DLFU637	37	50	845	497	600	245	485	493	8	1506	360	516	531
		100DLFU645	45	60	845	497	600	245	485	493	8	1506	360	516	553

***Note:** All dimensions are based on 4" discharge.

Dimensions

Project: _____ Model: _____ Chk'd: _____ Date: _____

**Model DLMFU
100DLMFU, 3 to 30HP**

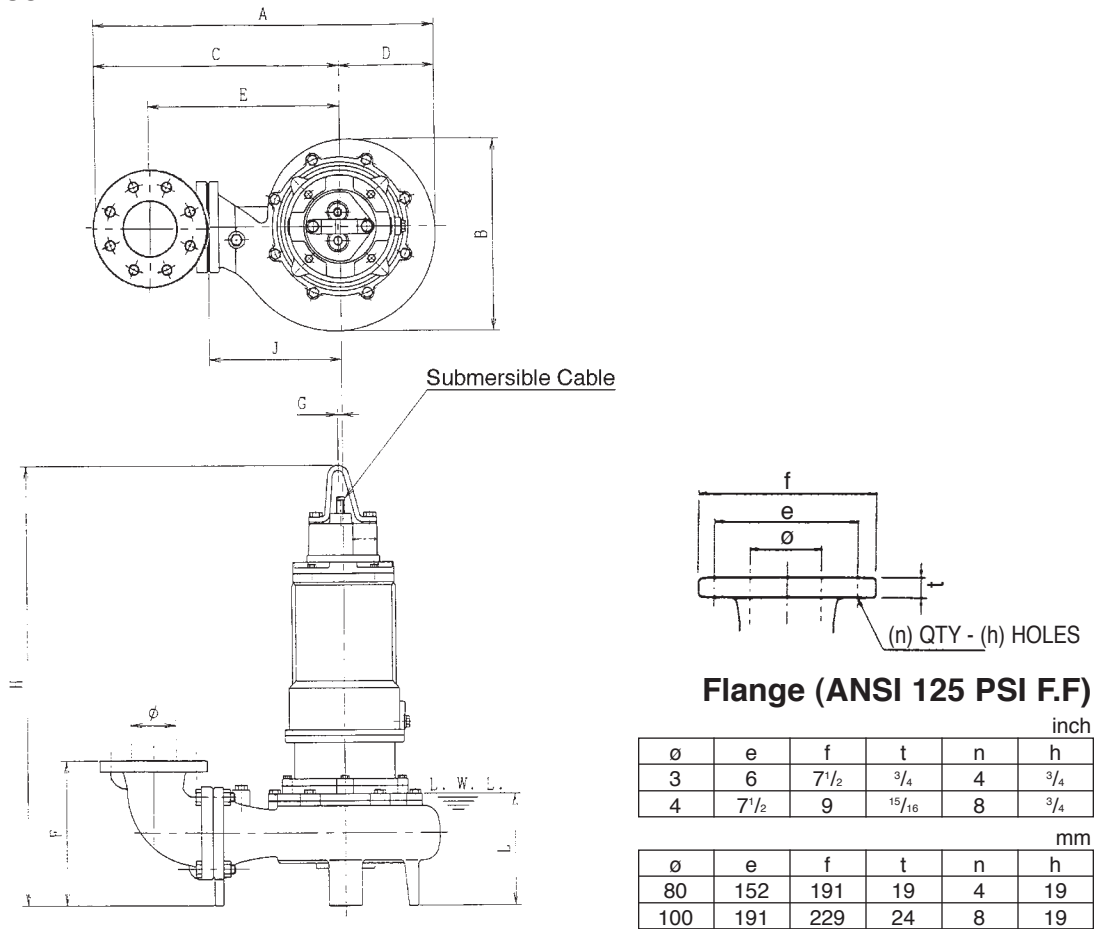

Dimensions: inch

PHASE	SIZE ø	MODEL	OUTPUT		PUMP & MOTOR										WEIGHT Lb
			KW	HP	A	B	C	D	E	F	G	H	J	L	
THREE	3/4	100DLMFU62.2	2.2	3	24 ⁹ / ₁₆	13 ⁹ / ₁₆	17 ¹⁵ / ₁₆	6 ⁵ / ₈	13 ³ / ₈	9 ¹³ / ₁₆	⁵ / ₁₆	30 ¹ / ₄	9 ¹ / ₄	8 ¹ / ₁₆	209
		100DLMFU63.7	3.7	5	24 ⁹ / ₁₆	13 ⁹ / ₁₆	17 ¹⁵ / ₁₆	6 ⁵ / ₈	13 ³ / ₈	9 ¹³ / ₁₆	⁵ / ₁₆	31 ¹³ / ₁₆	9 ¹ / ₄	8 ¹ / ₁₆	209
		100DLMFU65.5	5.5	7 ¹ / ₂	24 ⁹ / ₁₆	13 ⁹ / ₁₆	17 ¹⁵ / ₁₆	6 ⁵ / ₈	13 ³ / ₈	9 ¹³ / ₁₆	³ / ₈	37 ¹ / ₈	9 ¹ / ₄	11	317
		100DLMFU67.5	7.5	10	25 ¹³ / ₁₆	14 ¹ / ₂	18 ¹ / ₂	7 ⁵ / ₁₆	14	12 ¹¹ / ₁₆	³ / ₈	36 ¹ / ₁₆	9 ¹³ / ₁₆	10 ¹ / ₄	344
		100DLMFU611	11	15	26 ⁷ / ₈	15 ⁹ / ₁₆	18 ¹ / ₂	7 ⁵ / ₈	14 ³ / ₄	12 ¹¹ / ₁₆	⁵ / ₁₆	39 ⁹ / ₁₆	10 ⁵ / ₈	9 ¹³ / ₁₆	470
		100DLMFU615	15	20	26 ⁷ / ₈	15 ⁹ / ₁₆	18 ¹ / ₂	7 ⁵ / ₈	14 ³ / ₄	12 ¹¹ / ₁₆	⁵ / ₁₆	42 ⁵ / ₁₆	10 ⁵ / ₈	10 ¹³ / ₁₆	564
		100DLMFU618	18.5	25	28	15 ¹³ / ₁₆	20 ¹ / ₁₆	7 ¹⁵ / ₁₆	15 ⁹ / ₁₆	12 ¹¹ / ₁₆	⁵ / ₁₆	43 ⁷ / ₈	11 ⁷ / ₁₆	10 ¹³ / ₁₆	639
		100DLMFU622	22	30	28	15 ¹³ / ₁₆	20 ¹ / ₁₆	7 ¹⁵ / ₁₆	15 ⁹ / ₁₆	12 ¹¹ / ₁₆	⁵ / ₁₆	43 ⁷ / ₈	11 ⁷ / ₁₆	10 ¹³ / ₁₆	694

Dimensions: mm

PHASE	SIZE ø	MODEL	OUTPUT		PUMP & MOTOR										WEIGHT kg
			KW	HP	A	B	C	D	E	F	G	H	J	L	
THREE	80/100	100DLMFU62.2	2.2	3	624	335	455	169	340	250	8	768	235	205	95
		100DLMFU63.7	3.7	5	624	335	455	169	340	250	8	808	235	205	95
		100DLMFU65.5	5.5	7 ¹ / ₂	624	335	455	169	340	250	10	943	235	280	144
		100DLMFU67.5	7.5	10	655	369	470	186	355	323	10	916	250	260	156
		100DLMFU611	11	15	683	385	470	193	375	323	8	1005	270	250	213
		100DLMFU615	15	20	683	385	470	193	375	323	8	1075	270	275	256
		100DLMFU618	18.5	25	711	402	510	202	395	323	8	1115	290	275	290
		100DLMFU622	22	30	711	402	510	202	395	323	8	1115	290	275	315

***Note:** All dimensions are based on 4" discharge.

Dimensions

Project: _____ Model: _____ Chk'd: _____ Date: _____

Model DLFU
150DLFU, 10 to 60HP

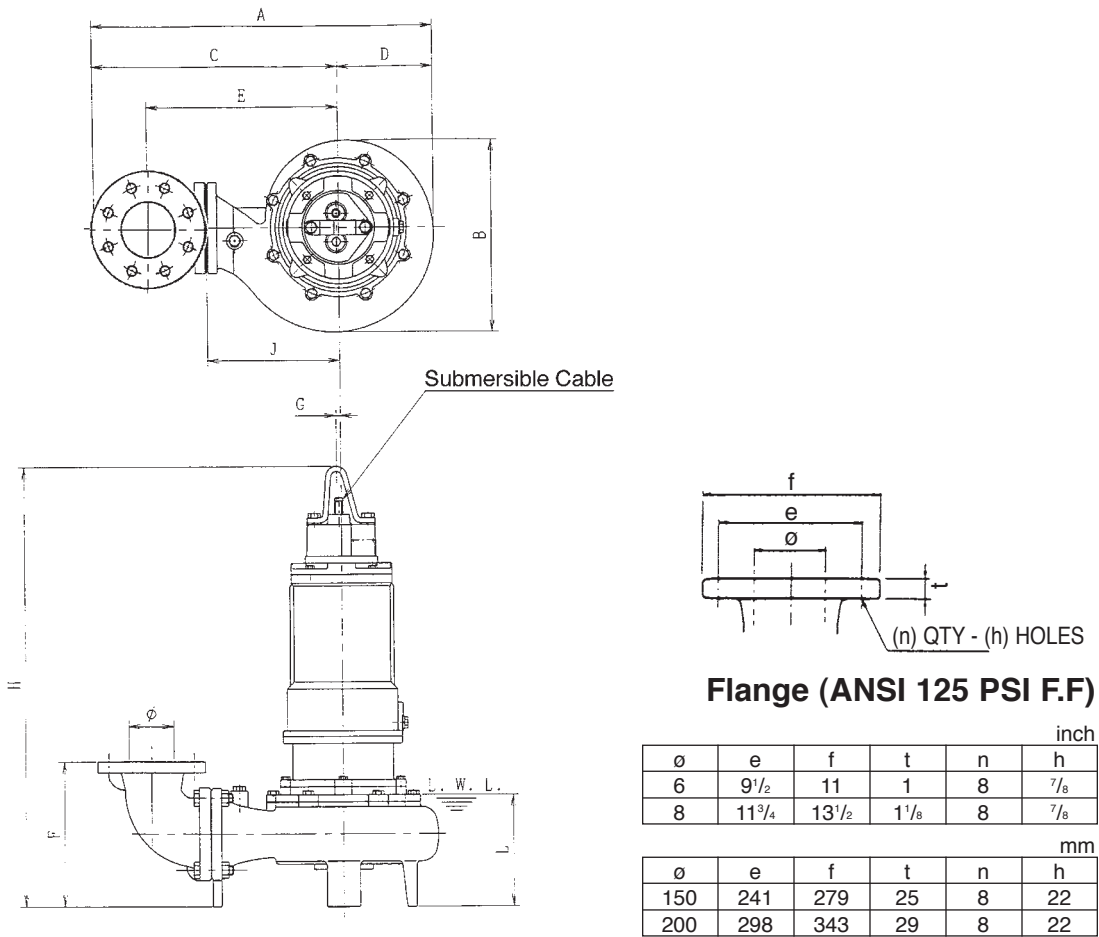

Dimensions: inch

PHASE	SIZE ø	MODEL	OUTPUT		PUMP & MOTOR										WEIGHT Lb
			KW	HP	A	B	C	D	E	F	G	H	J	L	
THREE	6/8	150DLFU67.5	7.5	10	31 ³ / ₄	16 ¹⁵ / ₁₆	23 ¹ / ₄	8 ⁹ / ₁₆	17 ¹¹ / ₁₆	16 ⁵ / ₁₆	3 ³ / ₈	38 ¹ / ₂	11 ¹³ / ₁₆	12 ³ / ₈	428
		150DLFU611	11	15	31 ³ / ₄	16 ¹⁵ / ₁₆	23 ¹ / ₄	8 ⁹ / ₁₆	17 ¹¹ / ₁₆	16 ⁵ / ₁₆	5 ¹ / ₁₆	42 ³ / ₁₆	11 ¹³ / ₁₆	12 ³ / ₈	549
		150DLFU615	15	20	33	17 ¹³ / ₁₆	24	9	18 ¹ / ₂	16 ¹ / ₈	5 ¹ / ₁₆	44 ¹ / ₄	12 ⁵ / ₈	12 ⁵ / ₈	635
		150DLFU618	18.5	25	33	17 ¹³ / ₁₆	24	9	18 ¹ / ₂	16 ¹ / ₈	5 ¹ / ₁₆	45 ¹³ / ₁₆	12 ⁵ / ₈	12 ⁵ / ₈	712
		150DLFU622	22	30	34 ¹ / ₄	18 ⁷ / ₈	24 ¹³ / ₁₆	9 ¹ / ₂	19 ⁹ / ₁₆	16 ⁵ / ₁₆	5 ¹ / ₁₆	45 ³ / ₄	13 ³ / ₈	12 ⁵ / ₈	787
		150DLFU630	30	40	32 ¹ / ₂	18 ⁹ / ₁₆	23 ¹ / ₄	9 ⁵ / ₁₆	17 ³ / ₄	23 ⁷ / ₈	5 ¹ / ₁₆	52 ⁹ / ₁₆	13 ³ / ₄	16 ¹ / ₈	1294
		150DLFU637	37	50	32 ¹ / ₂	18 ⁹ / ₁₆	23 ¹ / ₄	9 ⁵ / ₁₆	17 ³ / ₄	23 ⁷ / ₈	5 ¹ / ₁₆	55 ⁷ / ₈	13 ³ / ₄	16 ¹⁵ / ₁₆	1345
		150DLFU645	45	60	32 ¹ / ₂	18 ⁹ / ₁₆	23 ¹ / ₄	9 ⁵ / ₁₆	17 ³ / ₄	23 ⁷ / ₈	5 ¹ / ₁₆	55 ⁷ / ₈	13 ³ / ₄	16 ¹⁵ / ₁₆	1404

Dimensions: mm

PHASE	SIZE ø	MODEL	OUTPUT		PUMP & MOTOR										WEIGHT kg
			KW	HP	A	B	C	D	E	F	G	H	J	L	
THREE	150/200	150DLFU67.5	7.5	10	806	430	590	217	450	414	10	978	300	315	194
		150DLFU611	11	15	806	430	590	217	450	414	8	1071	300	315	249
		150DLFU615	15	20	838	453	610	228	470	410	8	1124	320	320	288
		150DLFU618	18.5	25	838	453	610	228	470	410	8	1164	320	320	323
		150DLFU622	22	30	870	479	630	241	490	411	8	1162	340	320	357
		150DLFU630	30	40	826	471	590	236	451	607	8	1335	350	409	587
		150DLFU637	37	50	826	471	590	236	451	607	8	1420	350	430	610
		150DLFU645	45	60	826	471	590	236	451	607	8	1420	350	430	637

Dimensions

Project: _____ Model: _____ Chk'd: _____ Date: _____

**Model DLFU
200DLFU, 10 to 60HP**

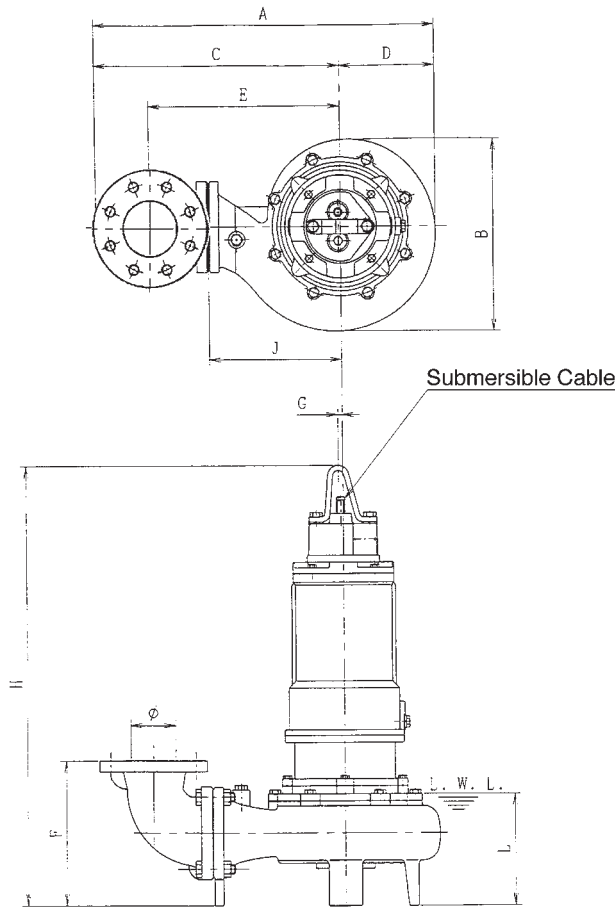

Flange (ANSI 125 PSI F.F)

ø	e	f	t	n	h
6	9 ¹ / ₂	11	1	8	⁷ / ₈
8	11 ³ / ₄	13 ¹ / ₂	1 ¹ / ₈	8	⁷ / ₈

mm					
ø	e	f	t	n	h
150	241	279	25	8	22
200	298	343	29	8	22

Dimensions: inch

PHASE	SIZE ø	MODEL	OUTPUT		PUMP & MOTOR										WEIGHT Lb
			KW	HP	A	B	C	D	E	F	G	H	J	L	
THREE	6/8	200DLFU67.5	7.5	10	33	16 ¹⁵ / ₁₆	24 ¹ / ₂	8 ⁹ / ₁₆	17 ¹¹ / ₁₆	16 ⁵ / ₁₆	³ / ₈	38 ¹ / ₂	11 ¹³ / ₁₆	12 ³ / ₈	428
		200DLFU611	11	15	33 ⁷ / ₁₆	16 ¹⁵ / ₁₆	24 ¹ / ₂	9	17 ¹¹ / ₁₆	16 ⁵ / ₁₆	⁵ / ₁₆	42 ³ / ₁₆	11 ¹³ / ₁₆	12 ³ / ₈	549
		200DLFU615	15	20	34 ¹ / ₄	17 ¹³ / ₁₆	25 ¹ / ₄	9	18 ¹ / ₂	16 ¹ / ₈	⁵ / ₁₆	44 ¹ / ₄	12 ⁵ / ₈	12 ⁵ / ₈	635
		200DLFU618	18.5	25	34 ³ / ₄	17 ¹³ / ₁₆	25 ¹ / ₄	9 ¹ / ₂	18 ¹ / ₂	16 ¹ / ₈	⁵ / ₁₆	45 ¹³ / ₁₆	12 ⁵ / ₈	12 ⁵ / ₈	712
		200DLFU622	22	30	34 ⁹ / ₁₆	18 ⁷ / ₈	26 ¹ / ₁₆	8 ⁹ / ₁₆	19 ⁹ / ₁₆	16 ³ / ₁₆	⁵ / ₁₆	45 ³ / ₄	13 ³ / ₈	12 ⁵ / ₈	787
		200DLFU630	30	40	35 ⁹ / ₁₆	20 ⁹ / ₁₆	24 ⁷ / ₈	10 ⁵ / ₁₆	18 ¹ / ₈	26 ⁹ / ₁₆	⁵ / ₁₆	54 ¹ / ₈	14 ³ / ₁₆	17 ¹¹ / ₁₆	1347
		200DLFU637	37	50	35 ³ / ₁₆	20 ⁹ / ₁₆	24 ⁷ / ₈	10 ⁵ / ₁₆	18 ¹ / ₈	26 ³ / ₁₆	⁵ / ₁₆	57 ¹ / ₂	14 ³ / ₁₆	18 ¹ / ₂	1398
		200DLFU645	45	60	35 ³ / ₁₆	20 ⁹ / ₁₆	24 ⁷ / ₈	10 ⁵ / ₁₆	18 ¹ / ₈	26 ³ / ₁₆	⁵ / ₁₆	57 ¹ / ₂	14 ³ / ₁₆	18 ¹ / ₂	1457

Dimensions: mm

PHASE	SIZE ø	MODEL	OUTPUT		PUMP & MOTOR										WEIGHT kg
			KW	HP	A	B	C	D	E	F	G	H	J	L	
THREE	150/200	200DLFU67.5	7.5	10	838	430	622	217	450	414	10	978	300	315	194
		200DLFU611	11	15	850	430	622	228	450	414	8	1071	300	315	249
		200DLFU615	15	20	870	453	642	228	470	410	8	1124	320	320	288
		200DLFU618	18.5	25	882	453	642	241	470	410	8	1164	320	320	323
		200DLFU622	22	30	878	479	662	217	490	411	8	1162	340	320	357
		200DLFU630	30	40	895	522	632	262	461	665	8	1375	360	449	611
		200DLFU637	37	50	895	522	632	262	461	665	8	1460	360	470	634
		200DLFU645	45	60	895	522	632	262	461	665	8	1460	360	470	661

Dimensions

Project: _____ Model: _____ Chk'd: _____ Date: _____

**Model DLFU
250DLFU, 15 to 60HP**

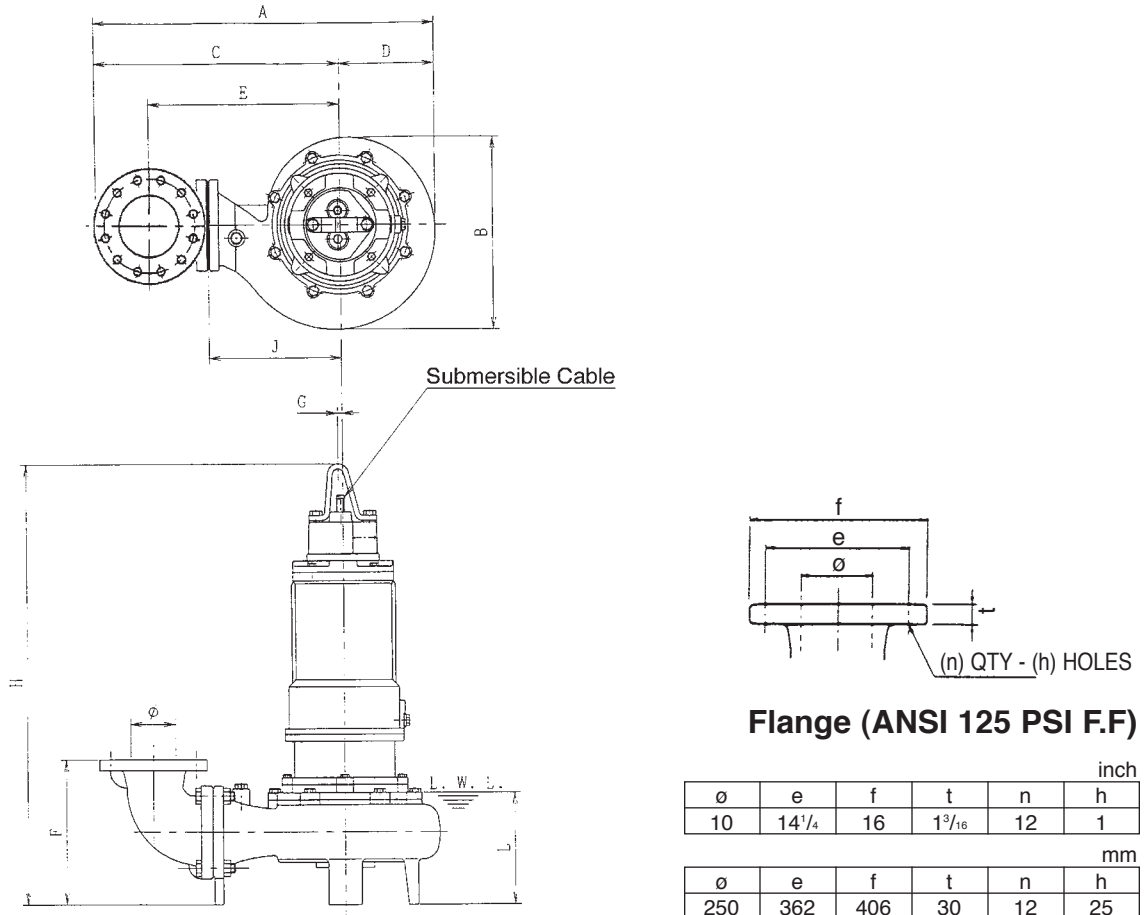

Dimensions: inch

PHASE	SIZE ø	MODEL	OUTPUT		PUMP & MOTOR										WEIGHT Lb
			kW	HP	A	B	C	D	E	F	G	H	J	L	
THREE	10	250DLFU611	11	15	38 ¹ / ₄	20 ⁵ / ₈	27 ¹¹ / ₁₆	10 ⁹ / ₁₆	19 ¹¹ / ₁₆	24 ¹ / ₂	5 ⁵ / ₁₆	45 ¹ / ₄	14 ⁹ / ₁₆	15 ³ / ₈	736
		250DLBFU615	15	20	38 ¹ / ₄	20 ⁵ / ₈	27 ¹¹ / ₁₆	10 ⁹ / ₁₆	19 ¹¹ / ₁₆	24 ¹ / ₂	5 ⁵ / ₁₆	47 ¹¹ / ₁₆	14 ⁹ / ₁₆	16 ¹ / ₈	833
		250DLCFU615	15	20	39 ³ / ₁₆	21 ⁵ / ₁₆	28 ⁷ / ₁₆	10 ³ / ₄	20 ¹ / ₂	24 ¹⁵ / ₁₆	5 ⁵ / ₁₆	47 ⁷ / ₈	15 ³ / ₈	16 ⁶ / ₁₆	877
		250DLFU618	18.5	25	39 ³ / ₁₆	21 ⁵ / ₁₆	28 ⁷ / ₁₆	10 ³ / ₄	20 ¹ / ₂	24 ¹⁵ / ₁₆	5 ⁵ / ₁₆	49 ⁷ / ₁₆	15 ³ / ₈	16 ⁶ / ₁₆	959
		250DLFU622	22	30	39 ³ / ₁₆	21 ⁵ / ₁₆	28 ⁷ / ₁₆	10 ³ / ₄	20 ¹ / ₂	24 ¹⁵ / ₁₆	5 ⁵ / ₁₆	49 ⁷ / ₁₆	15 ³ / ₈	16 ⁶ / ₁₆	1030
		250DLFU630	30	40	42 ³ / ₈	23 ¹¹ / ₁₆	30 ¹ / ₂	11 ¹⁵ / ₁₆	22 ¹ / ₂	29 ¹³ / ₁₆	5 ⁵ / ₁₆	57 ⁷ / ₁₆	17 ⁹ / ₁₆	20 ⁹ / ₁₆	1570
		250DLFU637	37	50	42 ³ / ₈	23 ¹¹ / ₁₆	30 ¹ / ₂	11 ¹⁵ / ₁₆	22 ¹ / ₂	29 ¹³ / ₁₆	5 ⁵ / ₁₆	60 ³ / ₈	17 ⁹ / ₁₆	21 ⁷ / ₁₆	1631
		250DLFU645	45	60	42 ³ / ₈	23 ¹¹ / ₁₆	30 ¹ / ₂	11 ¹⁵ / ₁₆	22 ¹ / ₂	29 ¹³ / ₁₆	5 ⁵ / ₁₆	60 ³ / ₈	17 ⁹ / ₁₆	21 ⁷ / ₁₆	1713

Dimensions: mm

PHASE	SIZE ø	MODEL	OUTPUT		PUMP & MOTOR										WEIGHT kg
			kW	HP	A	B	C	D	E	F	G	H	J	L	
THREE	250	250DLFU611	11	10	972	524	703	269	500	622	8	1149	370	390	334
		250DLBFU615	15	20	972	524	703	269	500	622	8	1211	370	410	378
		250DLCFU615	15	20	996	541	723	273	520	634	8	1216	390	415	398
		250DLFU618	18.5	25	996	541	723	273	520	634	8	1256	390	415	435
		250DLFU622	22	30	996	541	723	273	520	634	8	1256	390	415	467
		250DLFU630	30	40	1077	602	774	304	571	757	8	1449	440	523	712
		250DLFU637	37	50	1077	602	774	304	571	757	8	1534	440	544	740
		250DLFU645	45	60	1077	602	774	304	571	757	8	1534	440	544	777

Dimensions

Project: _____ Model: _____ Chk'd: _____ Date: _____

**Model DLFU
300DLFU, 25 to 60HP**

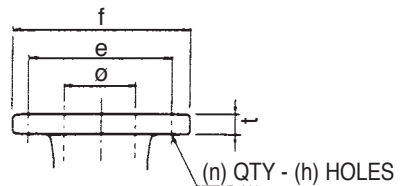
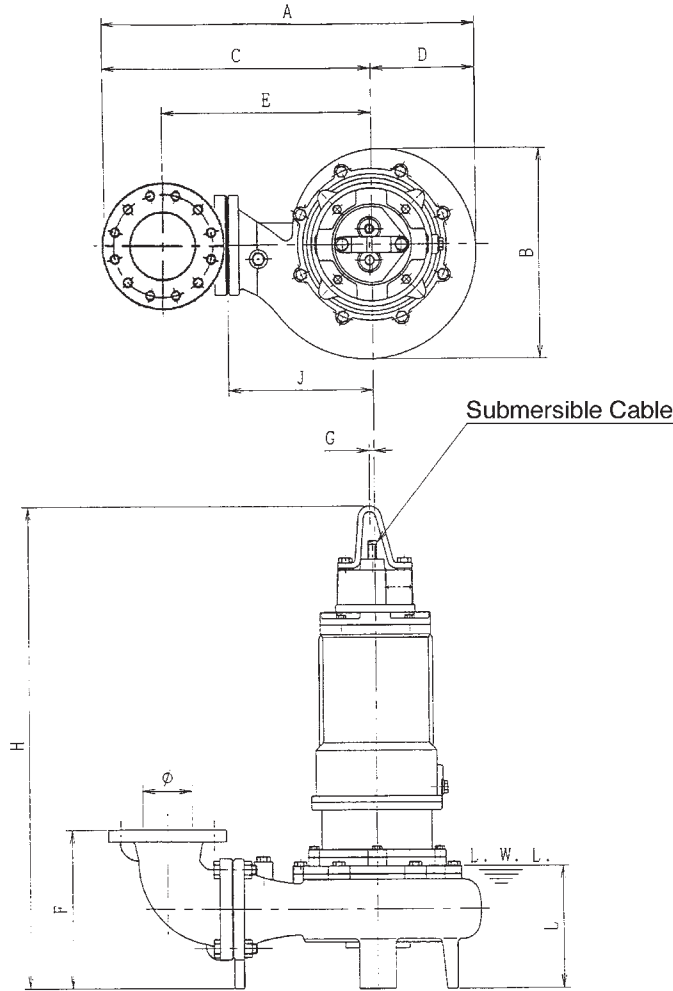

Flange (ANSI 125 PSI F.F)

inch					
ø	e	f	t	n	h
12	17	19	1 ¹ / ₄	12	1

mm					
ø	e	f	t	n	h
300	432	483	32	12	25

Dimensions: inch

PHASE	SIZE ø	MODEL	OUTPUT		PUMP & MOTOR										WEIGHT Lb
			kW	HP	A	B	C	D	E	F	G	H	J	L	
THREE	12	300DLFU618	18.5	25	44	23 ¹ / ₈	32 ³ / ₁₆	11 ⁷ / ₈	22 ⁵ / ₈	26 ⁷ / ₁₆	5 ⁵ / ₁₆	51 ¹ / ₈	16 ⁹ / ₁₆	17 ¹⁵ / ₁₆	1047
		300DLFU622	22	30	44	23 ¹ / ₈	32 ³ / ₁₆	11 ⁷ / ₈	22 ⁵ / ₈	26 ⁷ / ₁₆	5 ⁵ / ₁₆	51 ¹ / ₈	16 ⁹ / ₁₆	17 ¹⁵ / ₁₆	1107
		300DLFU630	30	40	49 ¹ / ₈	27 ⁵ / ₁₆	35 ⁵ / ₁₆	13 ¹³ / ₁₆	25 ¹³ / ₁₆	34 ¹ / ₈	5 ⁵ / ₁₆	60 ¹³ / ₁₆	19 ¹¹ / ₁₆	24 ⁵ / ₁₆	1733
		300DLFU637	37	50	49 ¹ / ₈	27 ⁵ / ₁₆	35 ⁵ / ₁₆	13 ¹³ / ₁₆	25 ¹³ / ₁₆	34 ¹ / ₈	5 ⁵ / ₁₆	64 ¹ / ₈	19 ¹¹ / ₁₆	25 ³ / ₁₆	1795
		300DLFU645	45	60	49 ¹ / ₈	27 ⁵ / ₁₆	35 ⁵ / ₁₆	13 ¹³ / ₁₆	25 ¹³ / ₁₆	34 ¹ / ₈	5 ⁵ / ₁₆	64 ¹ / ₈	19 ¹¹ / ₁₆	25 ³ / ₁₆	1876

Dimensions: mm

PHASE	SIZE ø	MODEL	OUTPUT		PUMP & MOTOR										WEIGHT kg
			kW	HP	A	B	C	D	E	F	G	H	J	L	
THREE	300	300DLFU618	18.5	25	1118	587	817	302	575	671	8	1298	420	455	475
		300DLFU622	22	30	1118	587	817	302	575	671	8	1298	420	455	502
		300DLFU630	30	40	1248	693	897	351	656	867	8	1544	500	618	786
		300DLFU637	37	50	1248	693	897	351	656	867	8	1629	500	639	814
		300DLFU645	45	60	1248	693	897	351	656	867	8	1629	500	639	851

Dimensions

Project: _____ Model: _____ Chk'd: _____ Date: _____

Model DLFU with Quick Discharge Connector
50DLFU, 2HP
80DLFU, 2HP
100DLFU, 2 to 5HP

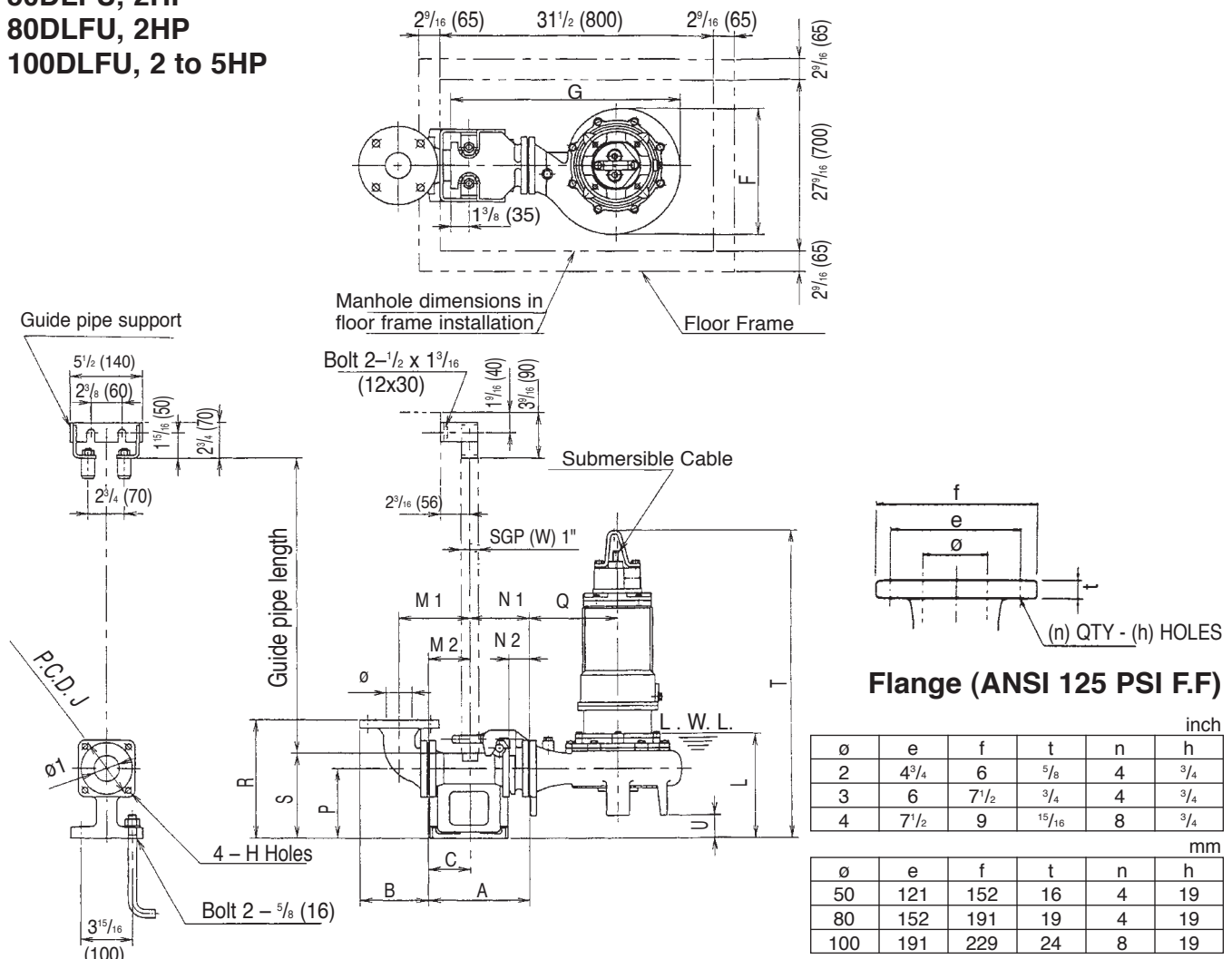

Dimensions: inch

PHASE	SIZE ø	MODEL	OUTPUT KW/HP	QDC MODEL	QDC													PUMP & MOTOR						WEIGHT Lb		
					A	B	C	H	J	M ₁	M ₂	N ₁	N ₂	P	R	S	ø1	F	G	L	Q	T	U	PUMP	QDC	
THREE	2/3	50DLFU61.5	1.5	2	LM65	8 ⁷ / ₁₆	6	3 ³ / ₄	1/2	5 ¹ / ₂	6 ² / ₁₆	3 ³ / ₄	4 ³ / ₄	1 ³ / ₄	5 ¹¹ / ₁₆	9 ¹³ / ₁₆	7 ¹ / ₂	2 ¹ / ₂	10 ⁵ / ₈	18 ¹ / ₄	8 ¹ / ₄	7 ¹ / ₁₆	29 ⁵ / ₈	1 ¹⁵ / ₁₆	132	31
		80DLFU61.5	1.5	2	LM80	8 ⁷ / ₁₆	6 ² / ₈	3 ⁹ / ₁₆	9 ¹ / ₁₆	6 ¹ / ₈	6 ¹ / ₂	3 ⁹ / ₁₆	4 ¹³ / ₁₆	1 ¹⁵ / ₁₆	6 ⁷ / ₈	11 ¹ / ₄	9 ¹ / ₁₆	3	11 ¹ / ₂	20 ⁵ / ₈	9 ⁵ / ₈	8 ¹ / ₄	31 ¹ / ₁₆	2 ⁹ / ₁₆	148	37
	3/4	100DLFU61.5	1.5	2	LM80	8 ⁷ / ₁₆	8 ¹ / ₄	3 ⁹ / ₁₆	9 ¹ / ₁₆	6 ¹ / ₈	7 ¹¹ / ₁₆	3 ⁹ / ₁₆	4 ¹⁵ / ₁₆	1 ¹⁵ / ₁₆	6 ⁷ / ₈	11 ¹³ / ₁₆	9 ¹ / ₁₆	3	10 ¹ / ₂	19 ⁷ / ₁₆	9 ⁵ / ₈	7 ⁷ / ₈	30 ³ / ₄	1	170	37
		100DLFU62.2	2.2	3	LM80	8 ⁷ / ₁₆	8 ¹ / ₄	3 ⁹ / ₁₆	9 ¹ / ₁₆	6 ¹ / ₈	7 ¹¹ / ₁₆	3 ⁹ / ₁₆	4 ¹⁵ / ₁₆	1 ¹⁵ / ₁₆	6 ⁷ / ₈	11 ¹³ / ₁₆	9 ¹ / ₁₆	3	11 ¹ / ₈	20 ¹ / ₂	9 ⁵ / ₈	8 ¹¹ / ₁₆	31 ³ / ₄	1	198	37
		100DLFU63.7	3.7	5	LM80	8 ⁷ / ₁₆	8 ¹ / ₄	3 ⁹ / ₁₆	9 ¹ / ₁₆	6 ¹ / ₈	7 ¹¹ / ₁₆	3 ⁹ / ₁₆	4 ¹³ / ₁₆	1 ¹⁵ / ₁₆	6 ⁷ / ₈	11 ¹³ / ₁₆	9 ¹ / ₁₆	3	11 ¹ / ₈	20 ¹ / ₂	9 ⁵ / ₈	8 ¹¹ / ₁₆	33 ³ / ₄	1	216	37

Dimensions: mm

PHASE	SIZE ø	MODEL	OUTPUT KW/HP	QDC MODEL	QDC													PUMP & MOTOR						WEIGHT kg		
					A	B	C	H	J	M ₁	M ₂	N ₁	N ₂	P	R	S	ø1	F	G	L	Q	T	U	PUMP	QDC	
THREE	50/80	50DLFU61.5	1.5	2	LM65	215	153	95	12	140	160	95	120	45	145	250	190	65	257	464	210	180	753	50	60	14
		80DLFU61.5	1.5	2	LM80	215	168	90	15	155	165	90	125	50	175	285	230	80	292	511	245	210	789	65	67	17
	80/100	100DLFU61.5	1.5	2	LM80	215	210	90	15	155	195	90	125	50	175	300	230	80	267	494	245	200	785	25	67	17
		100DLFU62.2	2.2	3	LM80	215	210	90	15	155	195	90	125	50	175	300	230	80	282	521	245	220	807	25	90	17
		100DLFU63.7	3.7	5	LM80	215	210	90	15	155	195	90	125	50	175	300	230	80	282	521	245	220	847	25	98	17

***Note:** All 80DLFU dimensions are based on 3" discharge.
 All 100DLFU dimensions are based on 4" discharge.

Dimensions

Project: _____ Model: _____ Chk'd: _____ Date: _____

**Model DLFU with Quick Discharge Connector
80DLMFU, 2 to 7½HP**

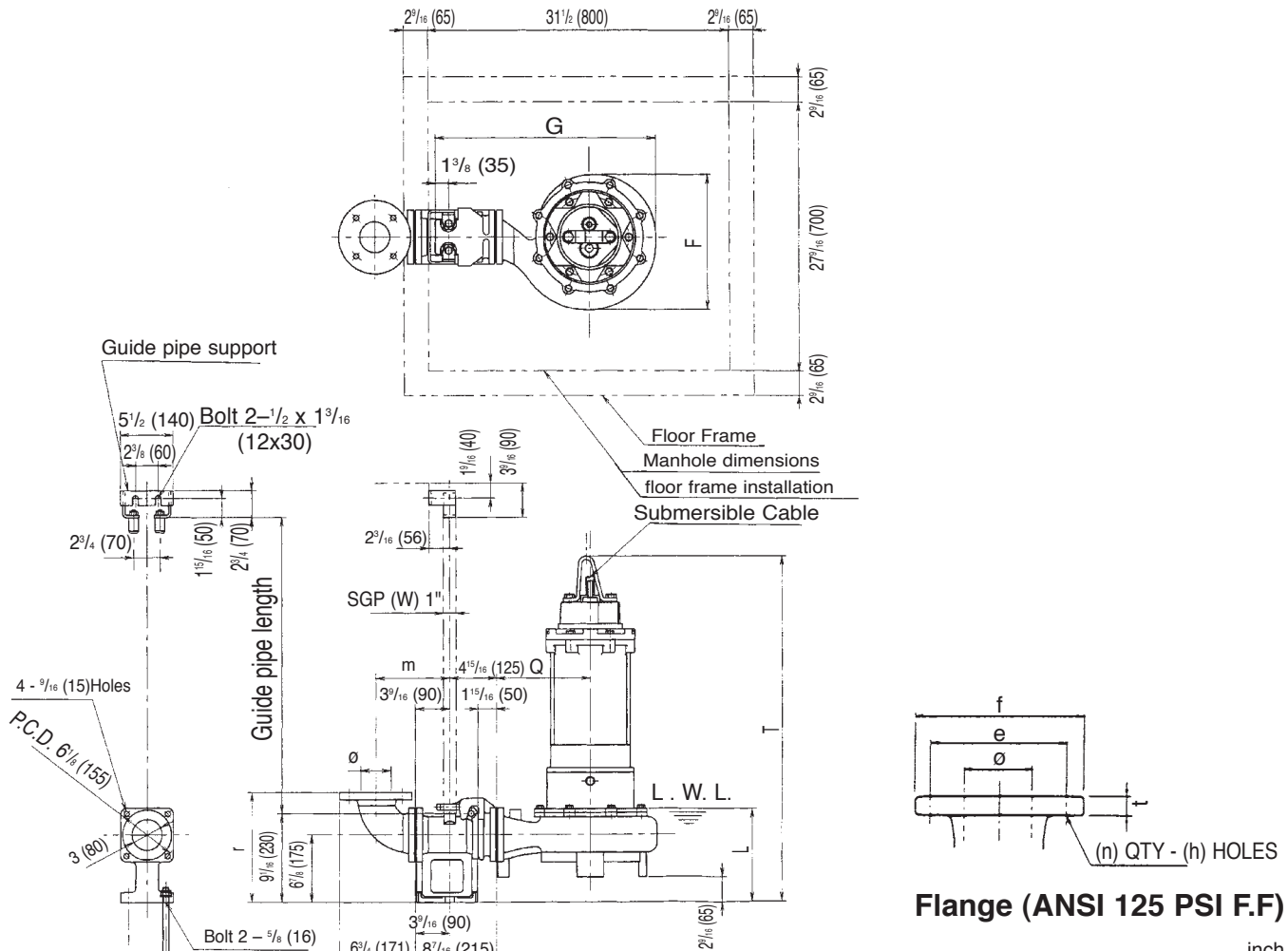

inch							
ø	e	f	t	n	h	r	m
3	6	7 1/2	3/4	4	3/4	11 3/16	6 1/2
4	7 1/2	9	15/16	8	3/4	11 13/16	7 11/16

mm							
ø	e	f	t	n	h	r	m
80	152	191	19	4	19	284	165
100	191	229	24	8	19	300	195

Dimensions: inch

PHASE	SIZE ø	PUMP MODEL	OUTPUT		Q.D.C. MODEL	PUMP & MOTOR					WEIGHT Lb	
			kw	HP		F	G	L	Q	T	PUMP	Q.D.C.
THREE	3/4	80DLMFU61.5	1.5	2	LM80	11 1/2	20 5/16	9 13/16	8 1/4	31 1/16	157	37
		80DLMFU62.2	2.2	3	LM80	11 1/2	20 5/16	9 15/16	8 1/4	32 1/16	187	37
		80DLMFU63.7	3.7	5	LM80	12 1/8	21	9 15/16	8 11/16	33 5/8	205	37
		80DLMFU65.5	5.5	7 1/2	LM80	12 15/16	22	12 2/8	9 1/4	38 15/16	311	37

Dimensions: mm

PHASE	SIZE ø	PUMP MODEL	OUTPUT		Q.D.C. MODEL	PUMP & MOTOR					WEIGHT kg	
			kw	HP		F	G	L	Q	T	PUMP	Q.D.C.
THREE	80/100	80DLMFU61.5	1.5	2	LM80	292	516	250	210	789	71	17
		80DLMFU62.2	2.2	3	LM80	292	516	253	210	815	85	17
		80DLMFU63.7	3.7	5	LM80	308	534	252	220	854	93	17
		80DLMFU65.5	5.5	7 1/2	LM80	328	559	327	235	989	141	17

Dimensions

Project: _____ Model: _____ Chk'd: _____ Date: _____

**Model DLFU with Quick Discharge Connector
80DLCMFU, 10 to 15HP**

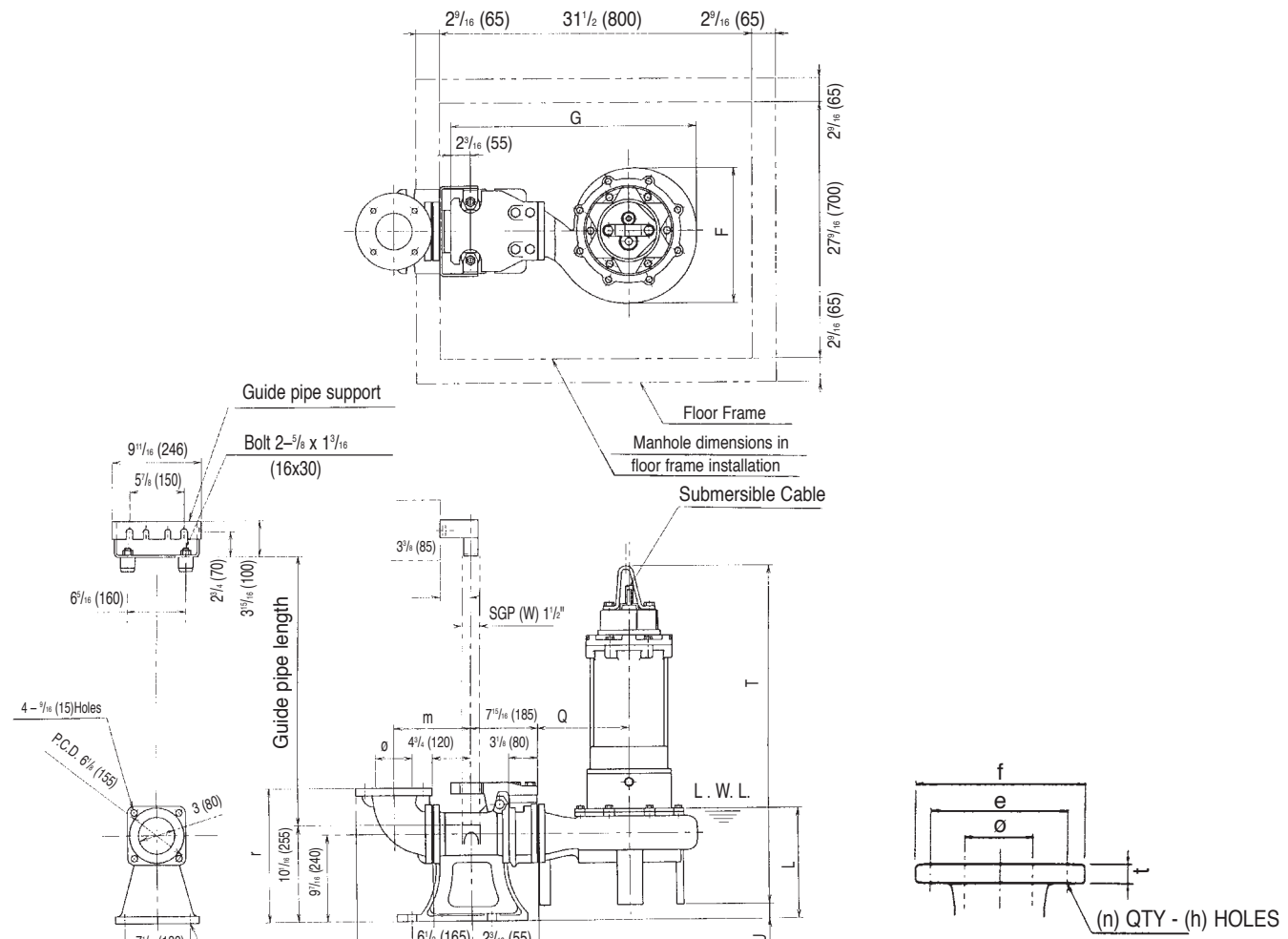

Flange (ANSI 125 PSI F.F)

inch							
ϕ	e	f	t	n	h	r	m
3	6	7 $\frac{1}{2}$	$\frac{3}{4}$	4	$\frac{3}{4}$	13 $\frac{3}{4}$	7 $\frac{11}{16}$
4	7 $\frac{1}{2}$	9	$\frac{15}{16}$	8	$\frac{3}{4}$	14 $\frac{3}{8}$	8 $\frac{7}{8}$
mm							
ϕ	e	f	t	n	h	r	m
80	152	191	19	4	19	350	195
100	191	229	24	8	19	365	226

Dimensions: inch

PHASE	SIZE ϕ	MODEL	OUTPUT		Q.D.C. MODEL	PUMP & MOTOR						WEIGHT Lb	
			KW	HP		F	G	L	Q	T	U	PUMP	Q.D.C.
THREE	3/4	80DLCMFU67.5	7.5	10	LL80	14 $\frac{15}{16}$	27 $\frac{3}{16}$	11 $\frac{1}{8}$	10 $\frac{1}{4}$	37 $\frac{9}{16}$	1 $\frac{11}{16}$	375	97
		80DLCMFU611	11	15	LL80	15 $\frac{11}{16}$	28 $\frac{3}{8}$	11 $\frac{1}{4}$	11	41 $\frac{1}{16}$	1 $\frac{3}{4}$	500	97

Dimensions: mm

PHASE	SIZE ϕ	MODEL	OUTPUT		Q.D.C. MODEL	PUMP & MOTOR						WEIGHT Lb	
			KW	HP		F	G	L	Q	T	U	PUMP	Q.D.C.
THREE	80/100	80DLCMFU67.5	7.5	10	LL80	379	690	283	260	948	43	170	44
		80DLCMFU611	11	15	LL80	399	720	285	280	1043	45	227	44

Dimensions

Project: _____ Model: _____ Chk'd: _____ Date: _____

**Model DLFU with Quick Discharge Connector
80DLFU, 3 to 30HP**

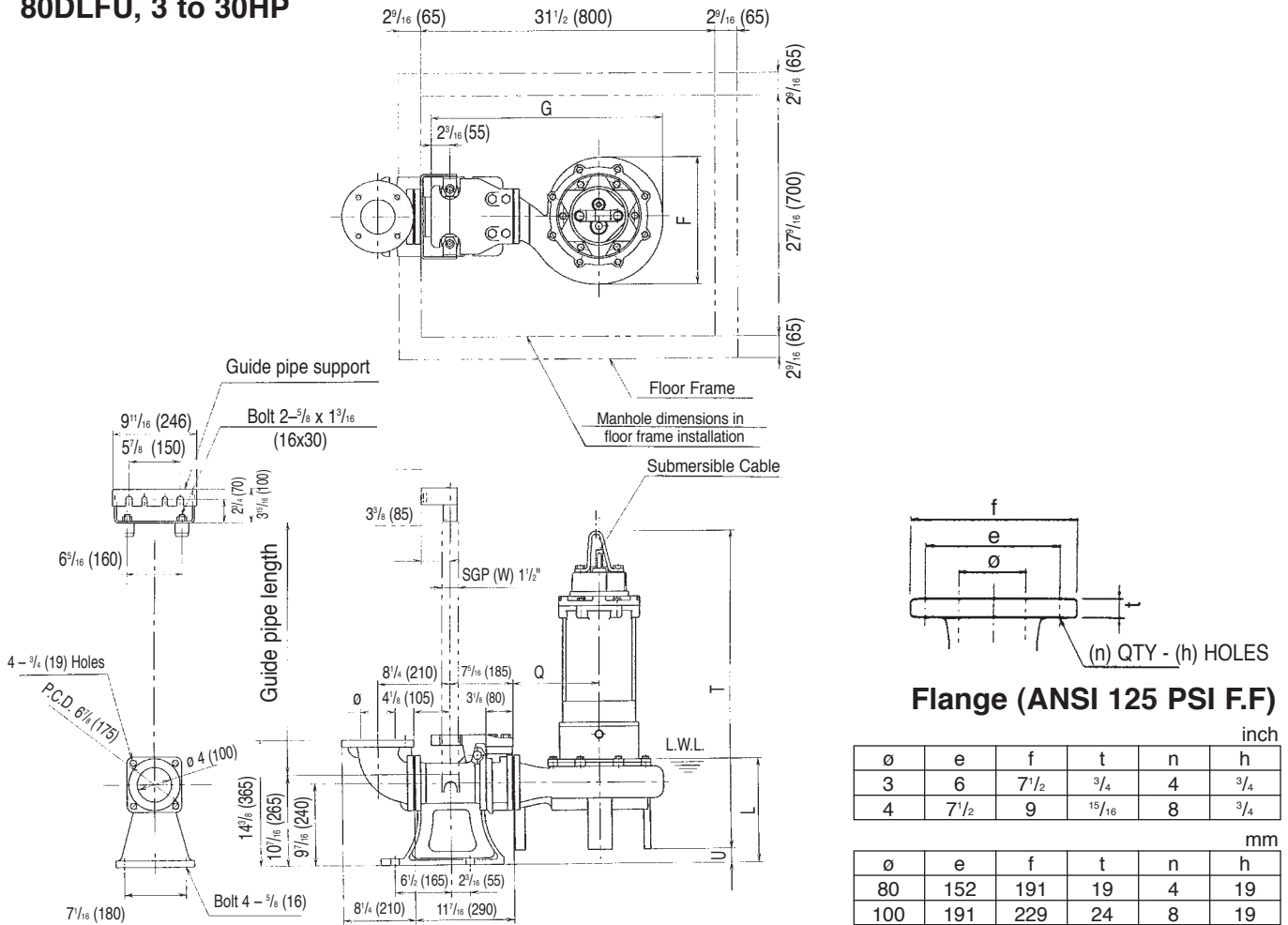

Flange (ANSI 125 PSI F.F)

inch					
ø	e	f	t	n	h
3	6	7 1/2	3/4	4	3/4
4	7 1/2	9	15/16	8	3/4

mm					
ø	e	f	t	n	h
80	152	191	19	4	19
100	191	229	24	8	19

Dimensions: inch

PHASE	SIZE ø	MODEL	OUTPUT		Q.D.C. MODEL	PUMP & MOTOR						WEIGHT Lb	
			kW	HP		F	G	L	Q	T	U	PUMP	Q.D.C.
THREE	3/4	80DLFU62.2	2.2	3	LL100	13 ^{3/16}	25 ^{3/8}	12 ^{5/8}	9 ^{1/4}	34 ^{3/4}	4 ^{1/2}	209	101
		80DLFU63.7	3.7	5	LL100	13 ^{3/16}	25 ^{3/8}	12 ^{5/8}	9 ^{1/4}	36 ^{5/16}	4 ^{1/2}	209	101
		80DLFU65.5	5.5	7 1/2	LL100	13 ^{3/16}	25 ^{3/8}	15 ^{9/16}	9 ^{1/4}	41 ^{5/8}	4 ^{1/2}	317	101
		80DLFU67.5	7.5	10	LL100	14 ^{1/2}	26 ^{9/16}	11 ^{13/16}	9 ^{13/16}	37 ^{11/16}	1 ^{5/8}	344	101
		80DLFU611	11	15	LL100	15 ^{3/16}	27 ^{11/16}	11 ^{5/8}	10 ^{5/8}	41 ^{5/16}	1 ^{5/8}	470	101
		80DLFU615	15	20	LL100	15 ^{3/16}	27 ^{11/16}	12 ^{3/8}	10 ^{5/8}	44 ^{1/8}	1 ^{5/8}	564	101
		80DLFU618	18.5	25	LL100	15 ^{13/16}	28 ^{3/4}	12 ^{3/8}	11 ^{7/16}	45 ^{11/16}	1 ^{5/8}	639	101
80DLFU622	22	30	LL100	15 ^{13/16}	28 ^{3/4}	12 ^{3/8}	11 ^{7/16}	45 ^{11/16}	1 ^{5/8}	694	101		

Dimensions: mm

PHASE	SIZE ø	MODEL	OUTPUT		Q.D.C. MODEL	PUMP & MOTOR						WEIGHT kg	
			kW	HP		F	G	L	Q	T	U	PUMP	Q.D.C.
THREE	80/100	80DLFU62.2	2.2	3	LL100	335	644	320	235	883	115	95	46
		80DLFU63.7	3.7	5	LL100	335	644	320	235	923	115	95	46
		80DLFU65.5	5.5	7 1/2	LL100	335	644	395	235	1058	115	144	46
		80DLFU67.5	7.5	10	LL100	369	675	300	250	958	42	156	46
		80DLFU611	11	15	LL100	385	703	295	270	1050	42	213	46
		80DLFU615	15	20	LL100	385	703	315	270	1120	42	256	46
		80DLFU618	18.5	25	LL100	402	730	315	290	1160	42	290	46
80DLFU622	22	30	LL100	402	730	315	290	1160	42	315	46		

Dimensions

Project: _____ Model: _____ Chk'd: _____ Date: _____

Model DLFU with Quick Discharge Connector
100DLMFU, 3 to 30HP

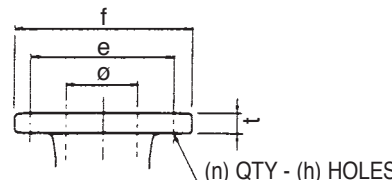
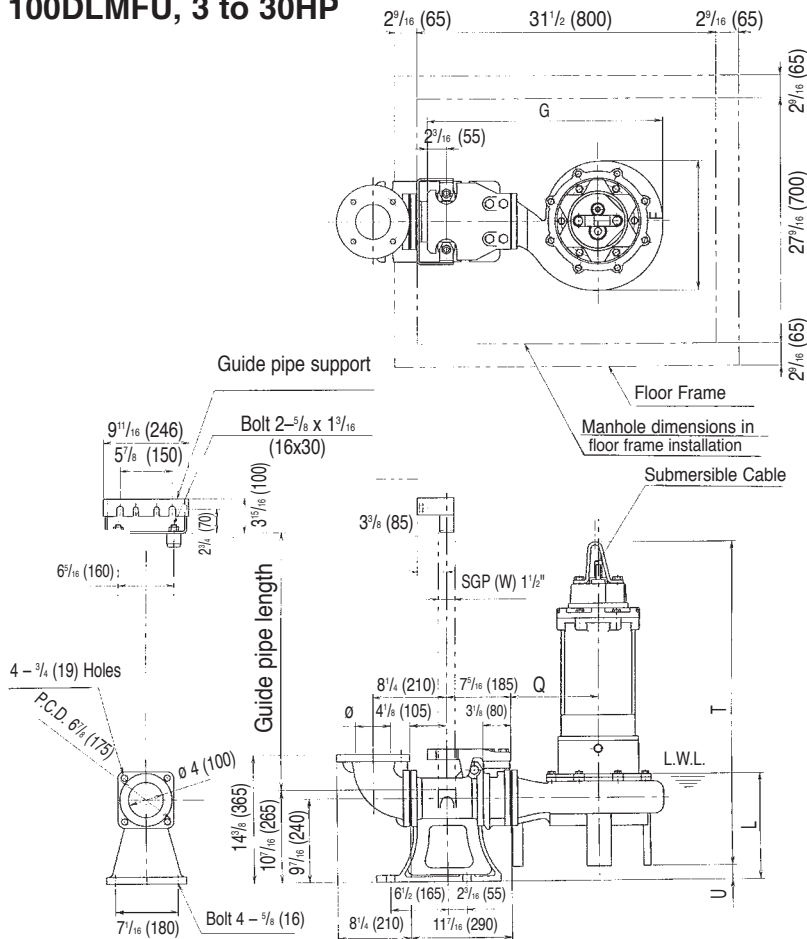

Flange (ANSI 125 PSI F.F)

inch					
ø	e	f	t	n	h
3	6	7 1/2	3/4	4	3/4
4	7 1/2	9	15/16	8	3/4

mm					
ø	e	f	t	n	h
80	152	191	19	4	19
100	191	229	24	8	19

Dimensions: inch

PHASE	SIZE ø	MODEL	OUTPUT		Q.D.C. MODEL	PUMP & MOTOR						WEIGHT Lb	
			kW	HP		F	G	L	Q	T	U	PUMP	Q.D.C.
THREE	3/4	100DLMFU62.2	2.2	3	LL100	13 ³ / ₁₆	25 ⁵ / ₈	12 ⁵ / ₈	9 ¹ / ₄	34 ³ / ₄	4 ¹ / ₂	209	101
		100DLMFU63.7	3.7	5	LL100	13 ³ / ₁₆	25 ⁵ / ₈	12 ⁵ / ₈	9 ¹ / ₄	36 ⁵ / ₁₆	4 ¹ / ₂	209	101
		100DLMFU65.5	5.5	7 1/2	LL100	13 ³ / ₁₆	25 ⁵ / ₈	15 ⁹ / ₁₆	9 ¹ / ₄	41 ⁵ / ₈	4 ¹ / ₂	317	101
		100DLMFU67.5	7.5	10	LL100	14 ¹ / ₂	26 ⁹ / ₁₆	11 ¹³ / ₁₆	9 ¹³ / ₁₆	37 ¹¹ / ₁₆	1 ⁵ / ₈	344	101
		100DLMFU611	11	15	LL100	15 ³ / ₁₆	27 ¹¹ / ₁₆	11 ⁵ / ₈	10 ⁵ / ₈	41 ⁵ / ₁₆	1 ⁵ / ₈	470	101
		100DLMFU615	15	20	LL100	15 ³ / ₁₆	27 ¹¹ / ₁₆	12 ³ / ₈	10 ⁵ / ₈	44 ¹ / ₈	1 ⁵ / ₈	564	101
		100DLMFU618	18.5	25	LL100	15 ¹³ / ₁₆	28 ³ / ₄	12 ³ / ₈	11 ⁷ / ₁₆	45 ¹¹ / ₁₆	1 ⁵ / ₈	639	101
100DLMFU622	22	30	LL100	15 ¹³ / ₁₆	28 ³ / ₄	12 ³ / ₈	11 ⁷ / ₁₆	45 ¹¹ / ₁₆	1 ⁵ / ₈	694	101		

Dimensions: mm

PHASE	SIZE ø	MODEL	OUTPUT		Q.D.C. MODEL	PUMP & MOTOR						WEIGHT kg	
			kW	HP		F	G	L	Q	T	U	PUMP	Q.D.C.
THREE	80/100	100DLMFU62.2	2.2	3	LL100	335	644	320	235	883	115	95	46
		100DLMFU63.7	3.7	5	LL100	335	644	320	235	923	115	95	46
		100DLMFU65.5	5.5	7 1/2	LL100	335	644	395	235	1058	115	144	46
		100DLMFU67.5	7.5	10	LL100	369	675	300	250	958	42	156	46
		100DLMFU611	11	15	LL100	385	703	295	270	1050	42	213	46
		100DLMFU615	15	20	LL100	385	703	315	270	1120	42	256	46
		100DLMFU618	18.5	25	LL100	402	730	315	290	1160	42	290	46
100DLMFU622	22	30	LL100	402	730	315	290	1160	42	315	46		

Dimensions

Project: _____ Model: _____ Chk'd: _____ Date: _____

Model DLFU with Quick Discharge Connector
100DLFU, 7½ to 30HP

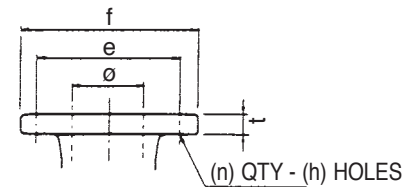
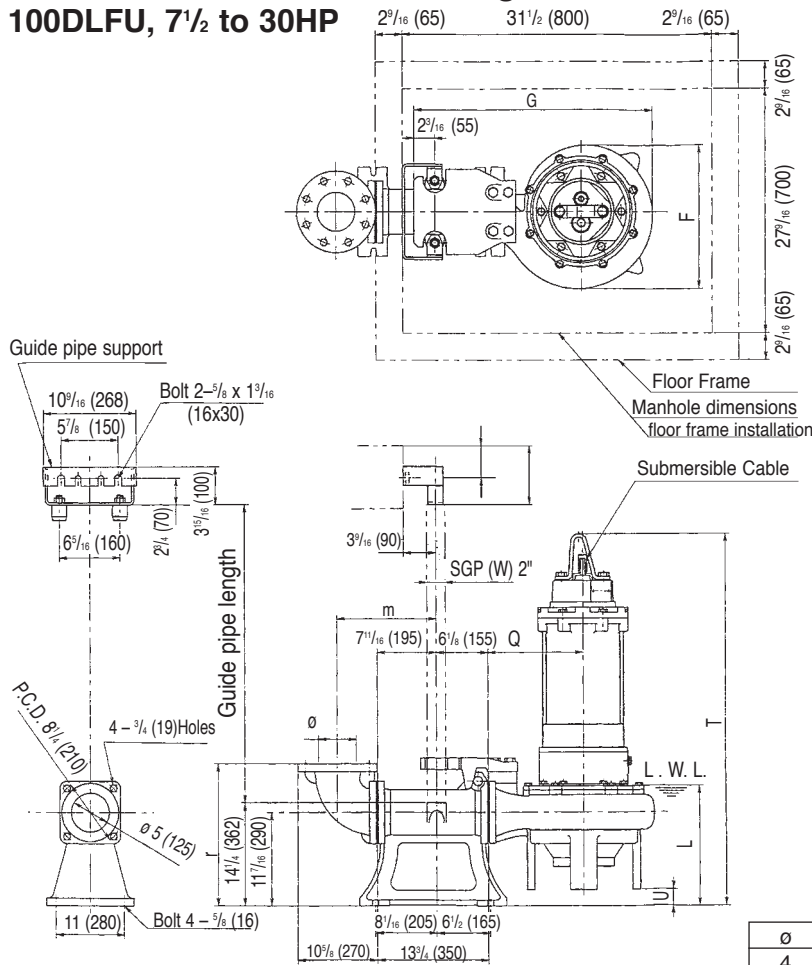

Flange (ANSI 125 PSI F.F)

inch							
ϕ	e	f	t	n	h	r	m
4	7 1/2	9	15 15/16	8	3/4	17 11/16	12 3/4
6	9 1/2	11	1	8	7/8	18 5/16	13 3/16
mm							
ϕ	e	f	t	n	h	r	m
100	191	191	19	8	19	450	325
150	241	229	24	8	22	465	345

Dimensions: inch

PHASE	SIZE ϕ	MODEL	OUTPUT		Q.D.C. MODEL	PUMP & MOTOR						WEIGHT Lb	
			kW	HP		F	G	L	Q	T	U	PUMP	Q.D.C.
THREE	4/6	100DLFU65.5	5.5	7 1/2	LL125	15 11/16	26 15/16	14 1/16	11	40 3/16	2 11/16	353	143
		100DLFU67.5	7.5	10	LL125	15 11/16	26 15/16	14 1/16	11	40 3/16	2 11/16	395	143
		100DLFU611	11	15	LL125	15 11/16	26 15/16	14 1/16	11	43 13/16	2 11/16	476	143
		100DLFU615	15	20	LL125	16 7/16	28 3/8	14 5/8	11 13/16	46 3/8	2 7/8	602	143
		100DLFU618	18.5	25	LL125	17 1/4	29 5/16	14 5/8	12 5/8	47 11/16	2 7/8	677	143
		100DLFU622	22	30	LL125	17 1/4	29 5/16	14 5/8	12 5/8	47 11/16	2 7/8	736	143

Dimensions: mm

PHASE	SIZE ϕ	MODEL	OUTPUT		Q.D.C. MODEL	PUMP & MOTOR						WEIGHT kg	
			kW	HP		F	G	L	Q	T	U	PUMP	Q.D.C.
THREE	100/150	100DLFU65.5	5.5	7 1/2	LL125	398	685	357	280	1020	69	160	65
		100DLFU67.5	7.5	10	LL125	398	685	357	280	1020	69	179	65
		100DLFU611	11	15	LL125	398	685	357	280	1113	69	216	65
		100DLFU615	15	20	LL125	417	715	371	300	1172	73	273	65
		100DLFU618	18.5	25	LL125	438	745	371	320	1212	73	307	65
		100DLFU622	22	30	LL125	438	745	371	320	1212	73	334	65

Dimensions

Project: _____ Model: _____ Chk'd: _____ Date: _____

Model DLFU with Quick Discharge Connector
100DLFU, 40 to 60HP

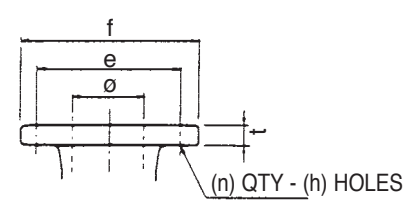
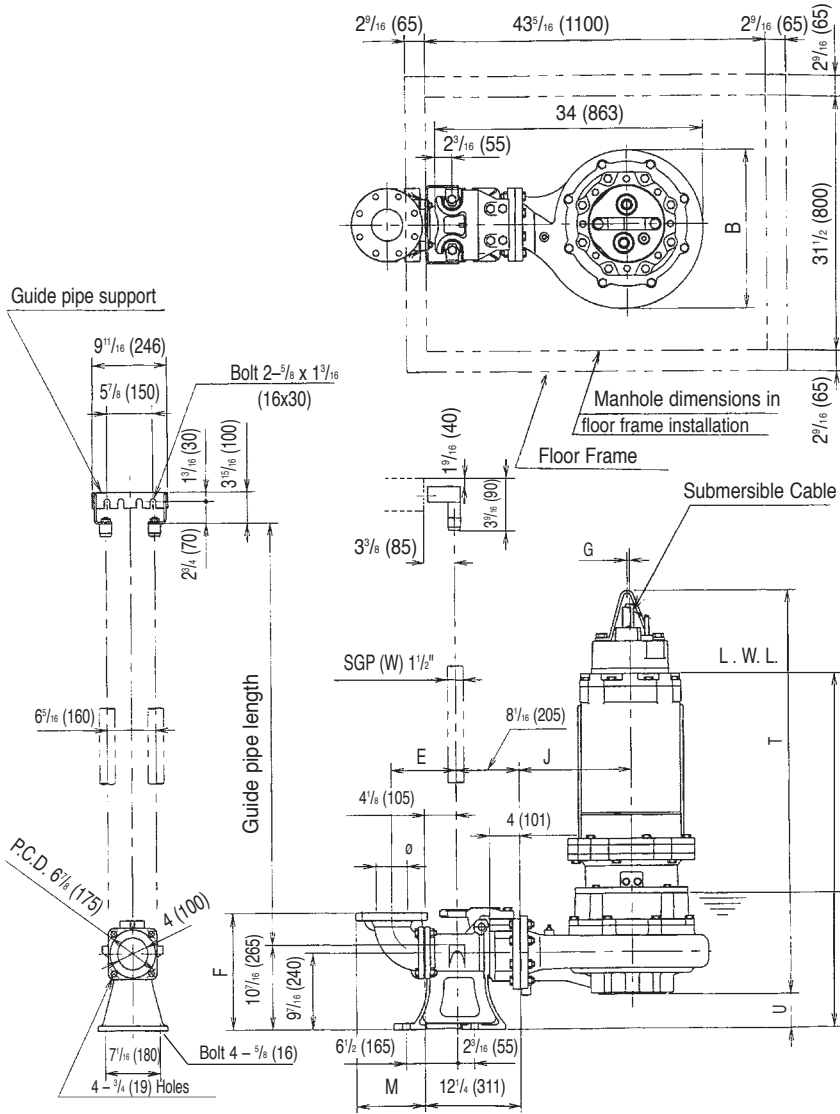

Flange (ANSI 125 PSI F.F)

inch					
Ø	e	f	t	n	h
4	7 1/2	9	1 5/16	8	3/4

mm					
Ø	e	f	t	n	h
100	191	229	24	8	19

Dimensions: inch

PHASE	SIZE Ø	MODEL	OUTPUT		Q.D.C. MODEL	PUMP & MOTOR							WEIGHT Lb			
			KW	HP		B	E	F	G	J	L	M	T	U	PUMP	Q.D.C.
THREE	4	100DLFU630	30	40	LL100	19 9/16	8 1/4	14 3/8	5/16	14 3/16	45 3/4	8 11/16	47 7/8	4 3/16	1001	106
		100DLFU637	37	50	LL100	19 9/16	8 1/4	14 3/8	5/16	14 3/16	45 3/4	8 11/16	51 7/16	4 3/16	1171	106
		100DLFU645	45	60	LL100	19 9/16	8 1/4	14 3/8	5/16	14 3/16	45 3/4	8 11/16	51 7/16	4 3/16	1219	106

Dimensions: mm

PHASE	SIZE Ø	MODEL	OUTPUT		Q.D.C. MODEL	PUMP & MOTOR							WEIGHT kg			
			KW	HP		B	E	F	G	J	L	M	T	U	PUMP	Q.D.C.
THREE	100	100DLFU630	30	40	LL100	497	210	365	8	360	397	220	1216	107	454	48
		100DLFU637	37	50	LL100	497	210	365	8	360	423	220	1306	107	531	48
		100DLFU645	45	60	LL100	497	210	365	8	360	423	220	1306	107	553	48

Dimensions

Project: _____ Model: _____ Chk'd: _____ Date: _____

Model DLFU with Quick Discharge Connector
150DLFU, 10 to 30HP

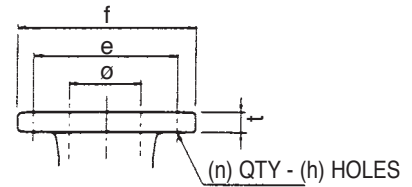
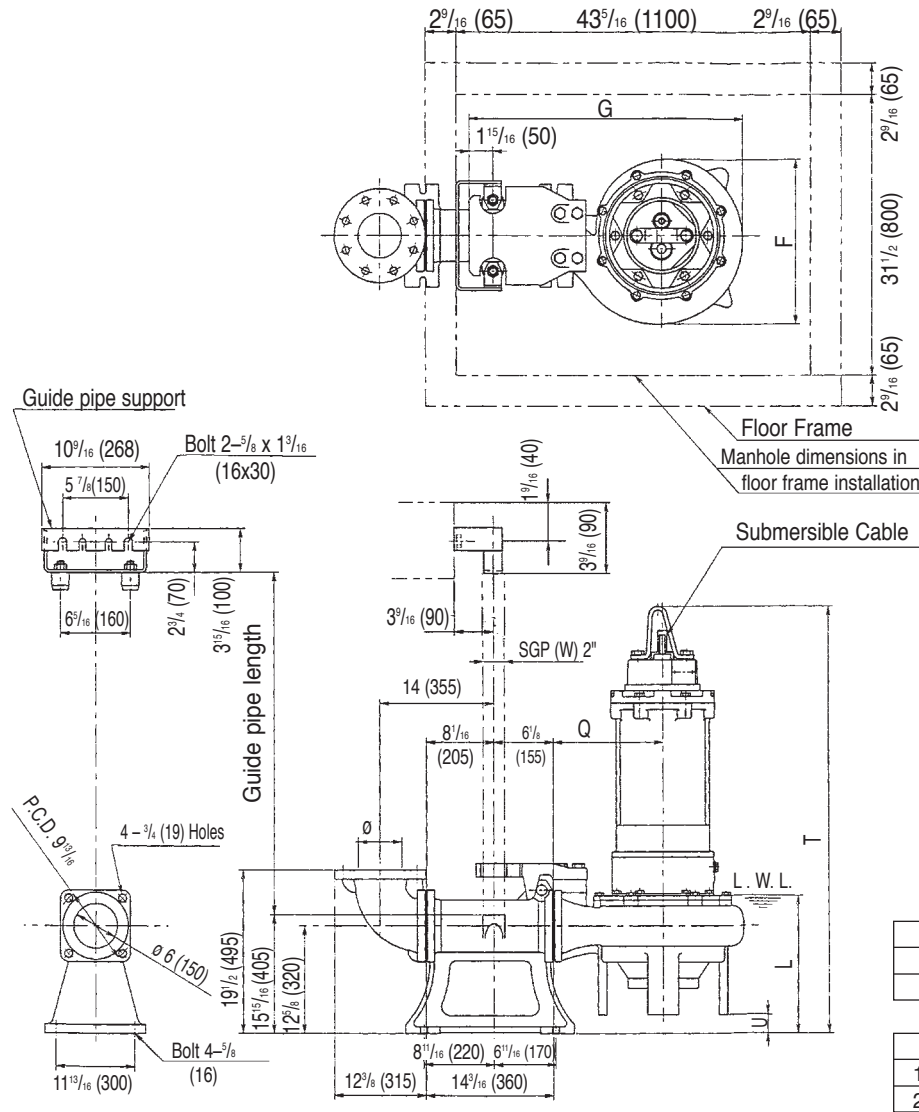

Flange (ANSI 125 PSI F.F)

inch					
ø	e	f	t	n	h
6	9 1/2	11	1	8	7/8
8	11 3/4	13 1/2	1 1/8	8	7/8

mm					
ø	e	f	t	n	h
150	241	279	25	8	22
200	298	343	29	8	22

Dimensions: inch

PHASE	SIZE ø	MODEL	OUTPUT		Q.D.C. MODEL	PUMP & MOTOR						WEIGHT Lb	
			kW	HP		F	G	L	Q	T	U	PUMP	Q.D.C.
THREE	6/8	150DLFU67.5	7.5	10	LL150	16 15/16	28 7/16	15 9/16	11 13/16	41 11/16	3 3/16	428	176
		150DLFU611	11	15	LL150	16 15/16	28 7/16	15 9/16	11 13/16	45 5/8	3 3/16	549	176
		150DLFU615	15	20	LL150	17 13/16	29 5/8	16 1/16	12 5/8	47 5/8	3 3/8	635	176
		150DLFU618	18.5	25	LL150	17 13/16	29 5/8	16 1/16	12 5/8	49 3/16	3 3/8	712	176
		150DLFU622	22	30	LL150	18 7/8	30 15/16	15 5/16	13 3/8	49 1/16	3 3/16	787	176

Dimensions: mm

PHASE	SIZE ø	MODEL	OUTPUT		Q.D.C. MODEL	PUMP & MOTOR						WEIGHT kg	
			kW	HP		F	G	L	Q	T	U	PUMP	Q.D.C.
THREE	150/200	150DLFU67.5	7.5	10	LL150	430	722	396	300	1059	81	194	80
		150DLFU611	11	15	LL150	430	722	396	300	1152	81	249	80
		150DLFU615	15	20	LL150	453	753	408	320	1209	85	288	80
		150DLFU618	18.5	25	LL150	453	753	408	320	1249	85	323	80
		150DLFU622	22	30	LL150	479	786	405	340	1246	84	357	80

Dimensions

Project: _____ Model: _____ Chk'd: _____ Date: _____

Model DLFU with Quick Discharge Connector
200DLFU, 10 to 30HP

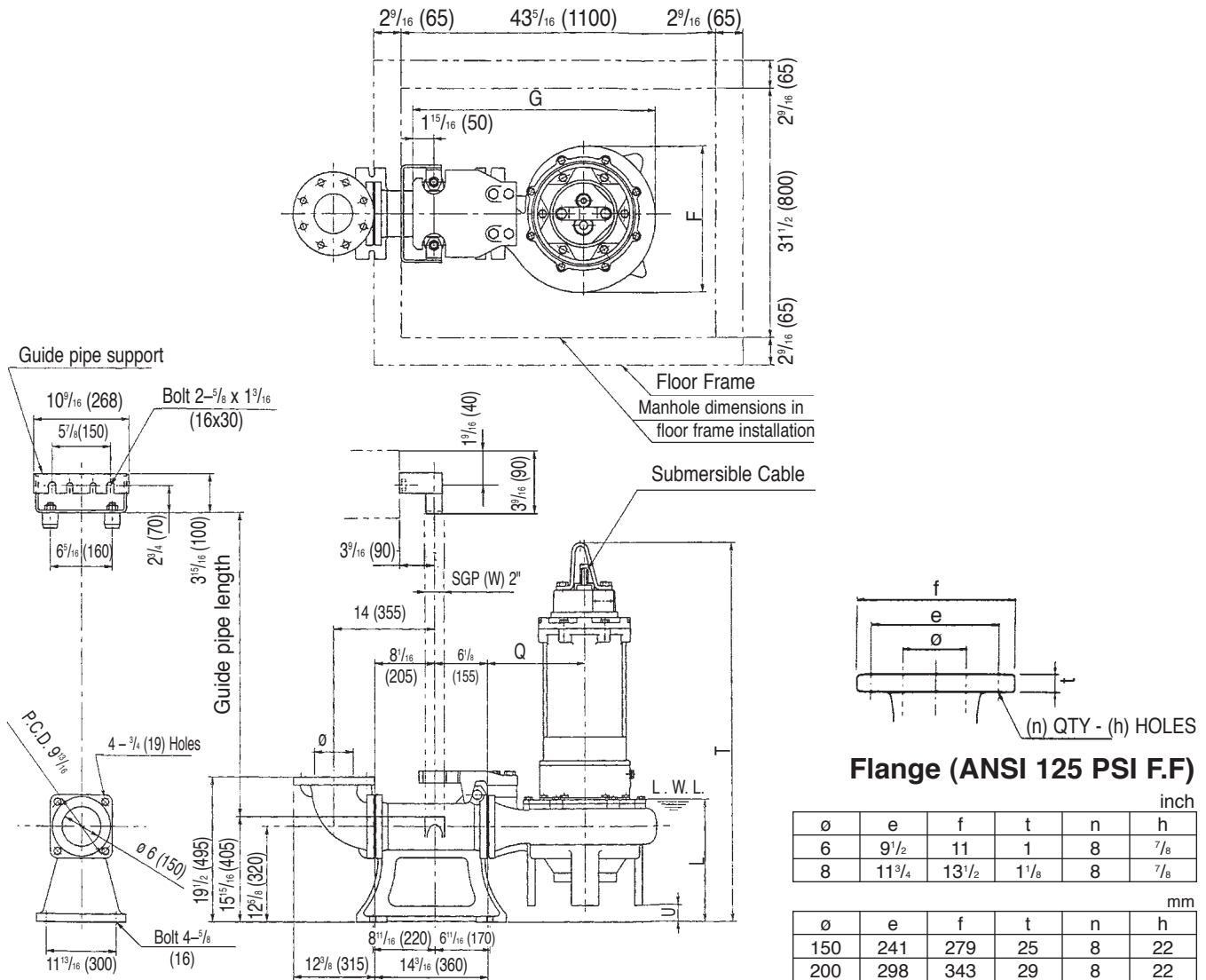

Dimensions: inch

PHASE	SIZE ø	MODEL	OUTPUT		Q.D.C. MODEL	PUMP & MOTOR						WEIGHT Lb	
			kW	HP		F	G	L	Q	T	U	PUMP	Q.D.C.
THREE	6/8	200DLFU67.5	7.5	10	LL150	16 15/16	28 7/16	15 9/16	11 13/16	41 11/16	3 3/16	428	176
		200DLFU611	11	15	LL150	16 15/16	28 7/16	15 9/16	11 13/16	45 3/8	3 3/16	549	176
		200DLFU615	15	20	LL150	17 13/16	29 9/8	16 1/16	12 5/8	47 5/8	3 3/8	635	176
		200DLFU618	18.5	25	LL150	17 13/16	29 9/8	16 1/16	12 5/8	49 3/16	3 3/8	712	176
		200DLFU622	22	30	LL150	18 7/8	30 15/16	15 15/16	13 3/8	49 1/16	3 9/16	787	176

Dimensions: mm

PHASE	SIZE ø	MODEL	OUTPUT		Q.D.C. MODEL	PUMP & MOTOR						WEIGHT kg	
			kW	HP		F	G	L	Q	T	U	PUMP	Q.D.C.
THREE	150/200	200DLFU67.5	7.5	10	LL150	430	722	396	300	1059	81	194	80
		200DLFU611	11	15	LL150	430	722	396	300	1152	81	249	80
		200DLFU615	15	20	LL150	453	753	408	320	1209	85	288	80
		200DLFU618	18.5	25	LL150	453	753	408	320	1249	85	323	80
		200DLFU622	22	30	LL150	479	786	405	340	1246	84	357	80

Dimensions

Project: _____ Model: _____ Chk'd: _____ Date: _____

Model DLFU with Quick Discharge Connector
150DLFU, 40 to 60HP
200DLFU, 40 to 60HP

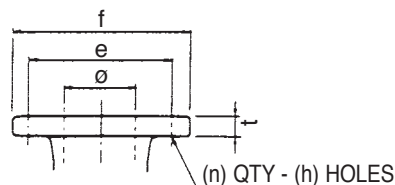
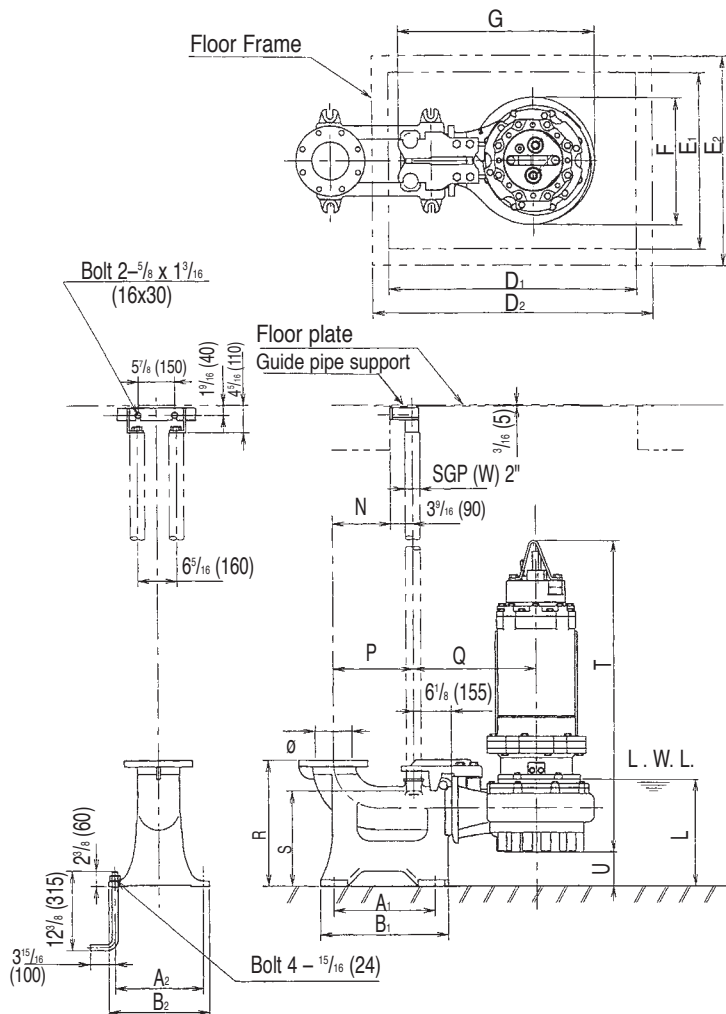

Flange (ANSI 125 PSI F.F)

inch					
ø	e	f	t	n	h
6	9 1/2	11	1	8	7/8
8	11 3/4	13 1/2	1 1/8	8	7/8

mm					
ø	e	f	t	n	h
150	241	279	25	8	22
200	298	343	29	8	22

Dimensions: inch

PHASE	SIZE ø	MODEL	OUTPUT		QDC MODEL	PUMP & MOTOR																ACCESS HOLE				WEIGHT Lb	
			kW	HP		A ₁	A ₂	B ₁	B ₂	F	G	L	N	P	Q	R	S	T	U	D ₁	D ₂	E ₁	E ₂	PUMP	QDC		
THREE	6	150DLFU630	30	40	LL150YU	16 1/8	14 3/16	20 1/2	16 1/8	18 9/16	31 5/16	15 3/16	9 1/4	12 3/16	19 7/8	19 11/16	15 5/16	47 1/16	5 1/4	39 3/4	44 7/8	27 3/16	32 1/16	1294	179		
		150DLFU637	37	50	LL150YU	16 1/8	14 3/16	20 1/2	16 1/8	18 9/16	31 5/16	16 5/8	9 1/4	12 3/16	19 7/8	19 11/16	15 5/16	50 5/8	5 1/4	39 3/4	44 7/8	27 3/16	32 1/16	1345	179		
		150DLFU645	45	60	LL150YU	16 1/8	14 3/16	20 1/2	16 1/8	18 9/16	31 5/16	16 5/8	9 1/4	12 3/16	19 7/8	19 11/16	15 5/16	50 5/8	5 1/4	39 3/4	44 7/8	27 3/16	32 1/16	1404	179		
	8	200DLFU630	30	40	LL200YU	17 3/16	16 3/16	21 5/8	18 1/2	20 9/16	32 1/2	17 1/2	10 7/16	14	20 1/4	23 3/8	16 3/4	47 1/8	6 7/8	43 3/8	48 7/8	31 1/2	36 5/8	1347	227		
		200DLFU637	37	50	LL200YU	17 3/16	16 3/16	21 5/8	18 1/2	20 9/16	32 1/2	18 3/8	10 7/16	14	20 1/4	23 3/8	16 3/4	50 5/8	6 7/8	43 3/8	48 7/8	31 1/2	36 5/8	1398	227		
		200DLFU645	45	60	LL200YU	17 3/16	16 3/16	21 5/8	18 1/2	20 9/16	32 1/2	18 3/8	10 7/16	14	20 1/4	23 3/8	16 3/4	50 5/8	6 7/8	43 3/8	48 7/8	31 1/2	36 5/8	1457	227		

Dimensions: mm

PHASE	SIZE ø	MODEL	OUTPUT		QDC MODEL	PUMP & MOTOR																ACCESS HOLE				WEIGHT kg	
			kW	HP		A ₁	A ₂	B ₁	B ₂	F	G	L	N	P	Q	R	S	T	U	D ₁	D ₂	E ₁	E ₂	PUMP	QDC		
THREE	150	150DLFU630	30	40	LL150YU	410	360	520	410	471	795	402	235	325	505	500	385	1195	133	1010	1140	700	830	587	81		
		150DLFU637	37	50	LL150YU	410	360	520	410	471	795	423	235	325	505	500	385	1280	133	1010	1140	700	830	610	81		
		150DLFU645	45	60	LL150YU	410	360	520	410	471	795	423	235	325	505	500	385	1280	133	1010	1140	700	830	637	81		
	200	200DLFU630	30	40	LL200YU	440	420	550	470	522	825	444	265	355	515	600	425	1195	175	1100	1230	800	930	611	103		
		200DLFU637	37	50	LL200YU	440	420	550	470	522	825	465	265	355	515	600	425	1280	175	1100	1230	800	930	634	103		
		200DLFU645	45	60	LL200YU	440	420	550	470	522	825	465	265	355	515	600	425	1280	175	1100	1230	800	930	661	103		

Dimensions

Project: _____ Model: _____ Chk'd: _____ Date: _____

**Model DLFU with Quick Discharge Connector
250DLFU, 15 to 30HP**

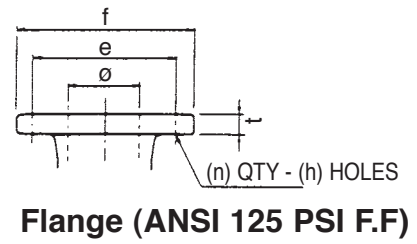
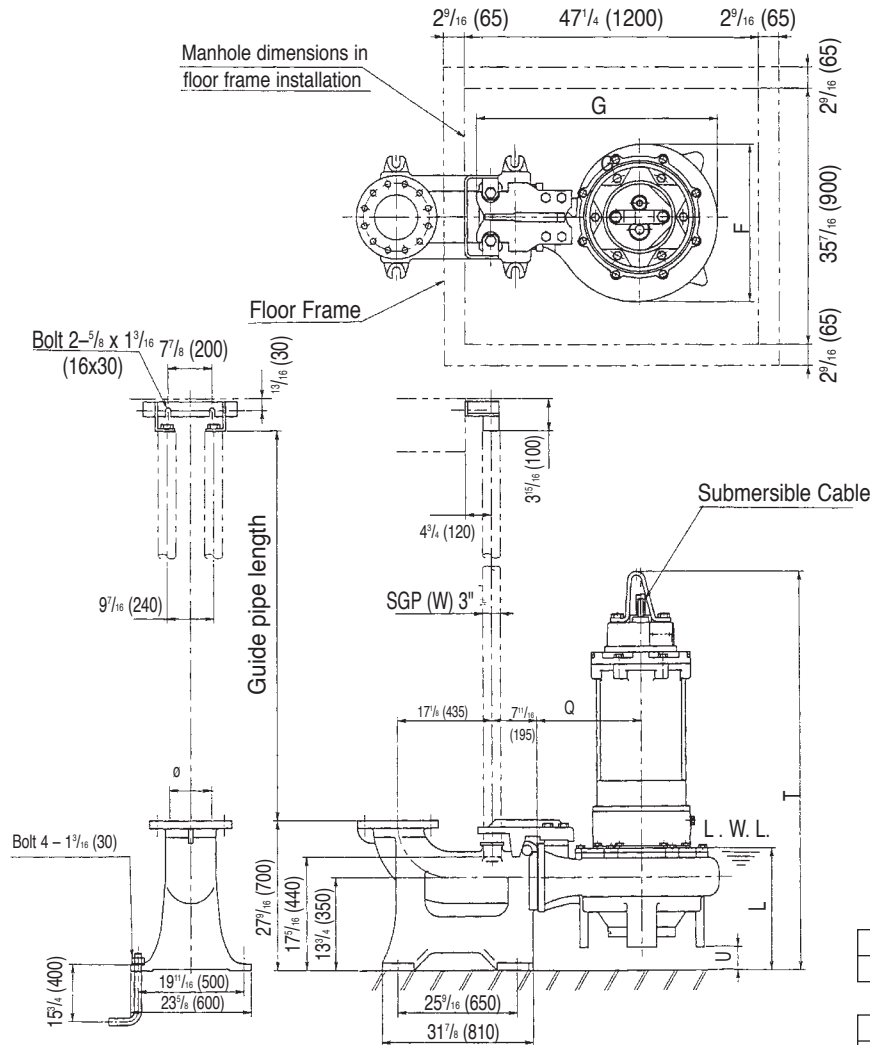

inch					
ø	e	f	t	n	h
10	14 1/4	16	1 3/16	12	1

mm					
ø	e	f	t	n	h
250	362	406	30	12	25

Dimensions: inch

PHASE	SIZE ø	MODEL	OUTPUT		Q.D.C. MODEL	PUMP & MOTOR						WEIGHT Lb	
			kW	HP		F	G	L	Q	T	U	PUMP	Q.D.C.
THREE	10	250DLFU611	11	15	LL250U	20 5/8	35 7/16	17 3/4	14 9/16	47 1/2	2 5/16	736	331
		250DLBFU615	15	20	LL250U	20 5/8	35 7/16	18 7/16	14 9/16	49 15/16	2 5/16	833	331
		250DLFCFU615	15	20	LL250U	21 5/16	36 3/8	18 1/8	15 3/8	49 11/16	1 13/16	877	331
		250DLFU618	18.5	25	LL250U	21 5/16	36 3/8	18 1/8	15 3/8	51 1/4	1 13/16	959	331
		250DLFU622	22	30	LL250U	21 5/16	36 3/8	18 1/8	15 3/8	51 1/4	1 13/16	1030	331

Dimensions: mm

PHASE	SIZE ø	MODEL	OUTPUT		Q.D.C. MODEL	PUMP & MOTOR						WEIGHT kg	
			kW	HP		F	G	L	Q	T	U	PUMP	Q.D.C.
THREE	250	250DLFU611	11	15	LL250U	524	900	451	370	1207	58	334	150
		250DLBFU615	15	20	LL250U	524	900	468	370	1269	58	378	150
		250DLFCFU615	15	20	LL250U	541	924	461	390	1262	46	398	150
		250DLFU618	18.5	25	LL250U	541	924	461	390	1302	46	435	150
		250DLFU622	22	30	LL250U	541	924	461	390	1302	46	467	150

Dimensions

Project: _____ Model: _____ Chk'd: _____ Date: _____

Model DLFU with Quick Discharge Connector
250DLFU, 40 TO 60HP
300DLFU, 40 TO 60HP

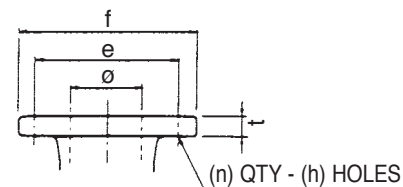
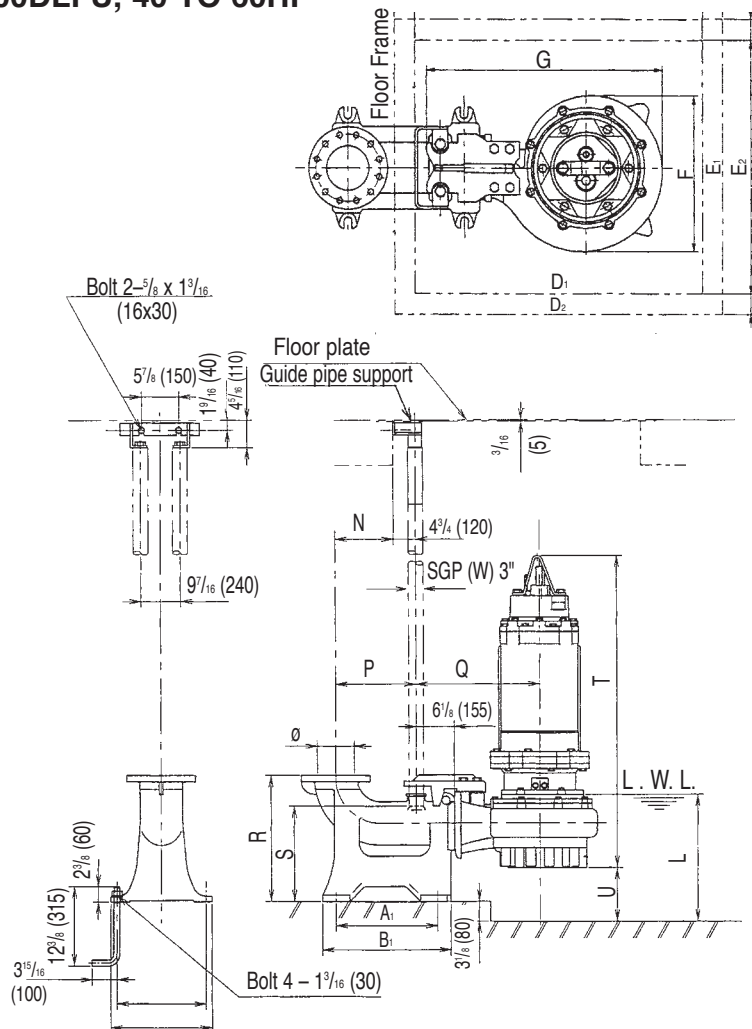

Flange (ANSI 125 PSI F.F)

inch					
ø	e	f	t	n	h
10	14 1/4	16	1 3/16	12	1
12	17	19	1 1/4	12	1

mm					
ø	e	f	t	n	h
250	362	406	30	12	25
300	432	483	32	12	25

Dimensions: inch

PHASE	SIZE ø	MODEL	OUTPUT		QDC MODEL	PUMP & MOTOR																ACCESS HOLE				WEIGHT Lb	
			KW	HP		A ₁	A ₂	B ₁	B ₂	F	G	L	N	P	Q	R	S	T	U	D ₁	D ₂	E ₁	E ₂	PUMP	QDC		
THREE	10	250DLFU630	30	40	LL250YU	25 9/16	19 11/16	31 1/8	22 1/16	23 11/16	39 3/4	17 9/16	12 3/8	17 1/8	25	27 9/16	17 9/16	48 9/16	8 3/4	47 1/4	53 3/8	35 7/16	41 5/16	1570	344		
		250DLFU637	37	50	LL250YU	25 9/16	19 11/16	31 1/8	22 1/16	23 11/16	39 3/4	18 9/16	12 3/8	17 1/8	25	27 9/16	17 9/16	51 1/4	8 3/4	47 1/4	53 3/8	35 7/16	41 5/16	1631	344		
		250DLFU645	45	60	LL250YU	25 9/16	19 11/16	31 1/8	22 1/16	23 11/16	39 3/4	18 9/16	12 3/8	17 1/8	25	27 9/16	17 9/16	51 1/4	8 3/4	47 1/4	53 3/8	35 7/16	41 5/16	1713	344		
	12	300DLFU630	30	40	LL300YU	26 3/4	22 3/16	32 3/16	25 3/16	27 9/16	43 3/8	20 3/8	13 9/16	18 3/16	27 3/8	31 1/2	21 5/8	50 9/16	9 15/16	51 3/16	57 1/16	39 3/8	45 1/4	1733	450		
		300DLFU637	37	50	LL300YU	26 3/4	22 3/16	32 3/16	25 3/16	27 9/16	43 3/8	21 3/4	13 9/16	18 3/16	27 3/8	31 1/2	21 5/8	53 3/8	9 9/16	51 3/16	57 1/16	39 3/8	45 1/4	1795	450		
		300DLFU645	45	60	LL300YU	26 3/4	22 3/16	32 3/16	25 3/16	27 9/16	43 3/8	21 3/4	13 9/16	18 3/16	27 3/8	31 1/2	21 5/8	53 3/8	9 9/16	51 3/16	57 1/16	39 3/8	45 1/4	1876	450		

Dimensions: mm

PHASE	SIZE ø	MODEL	OUTPUT		QDC MODEL	PUMP & MOTOR																ACCESS HOLE				WEIGHT kg	
			KW	HP		A ₁	A ₂	B ₁	B ₂	F	G	L	N	P	Q	R	S	T	U	D ₁	D ₂	E ₁	E ₂	PUMP	QDC		
THREE	250	250DLFU630	30	40	LL250YU	650	500	790	560	602	1010	446	315	435	635	700	440	1229	223	1200	1350	900	1050	712	156		
		250DLFU637	37	50	LL250YU	650	500	790	560	602	1010	467	315	435	635	700	440	1314	223	1200	1350	900	1050	740	156		
		250DLFU645	45	60	LL250YU	650	500	790	560	602	1010	467	315	435	635	700	440	1314	223	1200	1350	900	1050	777	156		
	300	300DLFU630	30	40	LL300YU	680	580	820	640	693	1115	531	345	465	695	800	550	1284	253	1300	1450	1000	1150	786	204		
		300DLFU637	37	50	LL300YU	680	580	820	640	693	1115	552	345	465	695	800	550	1369	253	1300	1450	1000	1150	814	204		
		300DLFU645	45	60	LL300YU	680	580	820	640	693	1115	552	345	465	695	800	550	1369	253	1300	1450	1000	1150	851	204		

Dimensions

Project: _____ Model: _____ Chk'd: _____ Date: _____

**Model DLFU with Quick Discharge Connector
300DLFU, 25 to 30HP**

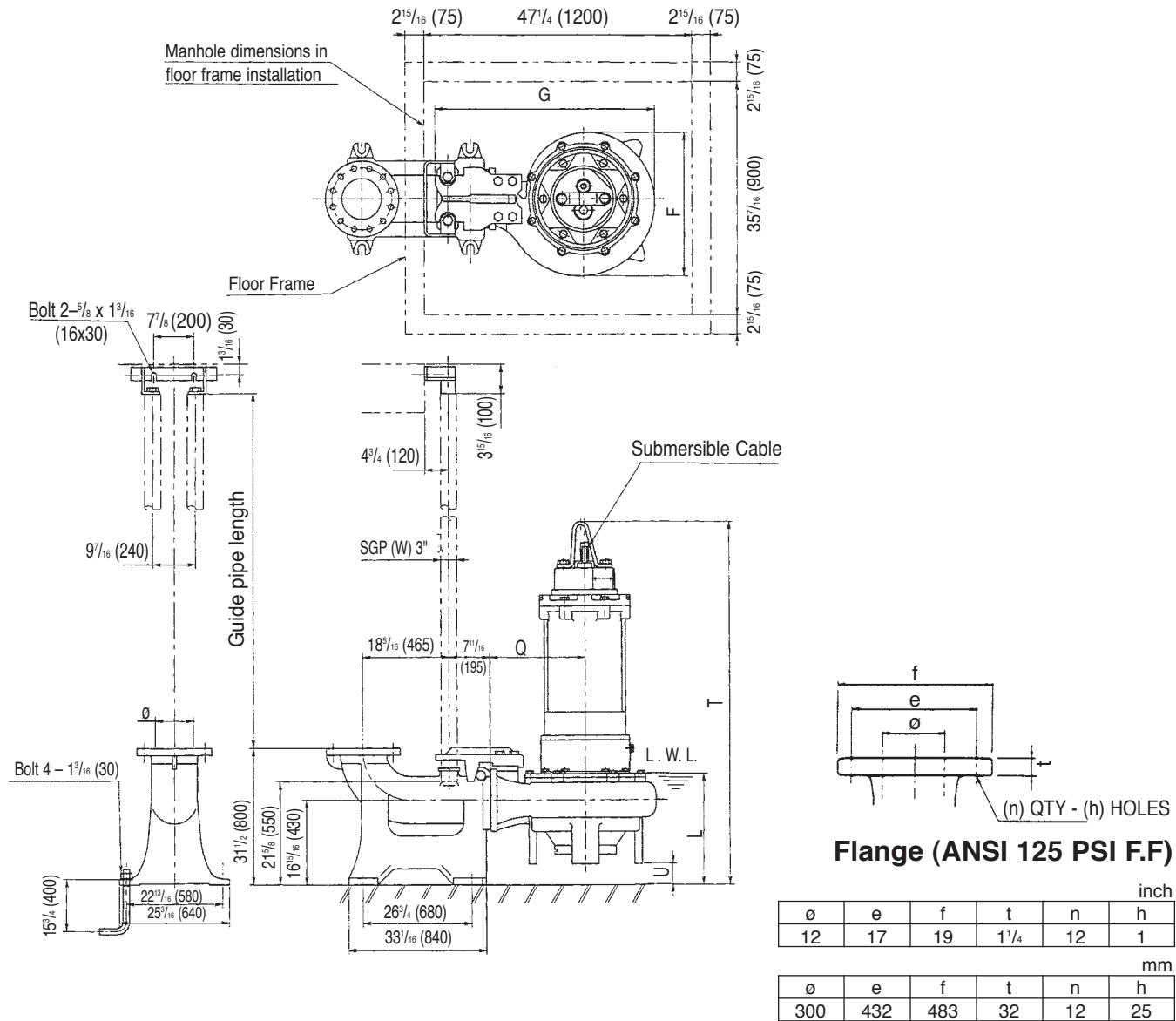

Dimensions: inch

PHASE	SIZE ø	MODEL	OUTPUT		Q.D.C. MODEL	PUMP & MOTOR						WEIGHT Lb	
			KW	HP		F	G	L	Q	T	U	PUMP	Q.D.C.
THREE	12	300DLFU618	18.5	25	LL300U	23 1/8	38 11/16	22 5/16	16 9/16	55 5/8	4 7/16	1047	331
		300DLFU622	22	30	LL300U	23 1/8	38 11/16	22 5/16	16 9/16	55 5/8	4 7/16	1107	331

Dimensions: mm

PHASE	SIZE ø	MODEL	OUTPUT		Q.D.C. MODEL	PUMP & MOTOR						WEIGHT kg	
			KW	HP		F	G	L	Q	T	U	PUMP	Q.D.C.
THREE	300	300DLFU618	18.5	25	LL300U	587	983	566	420	1407	109	475	150
		300DLFU622	22	30	LL300U	587	983	566	420	1407	109	502	150

Sectional View

Project: _____ Model: _____ Chk'd: _____ Date: _____

2 to 5HP

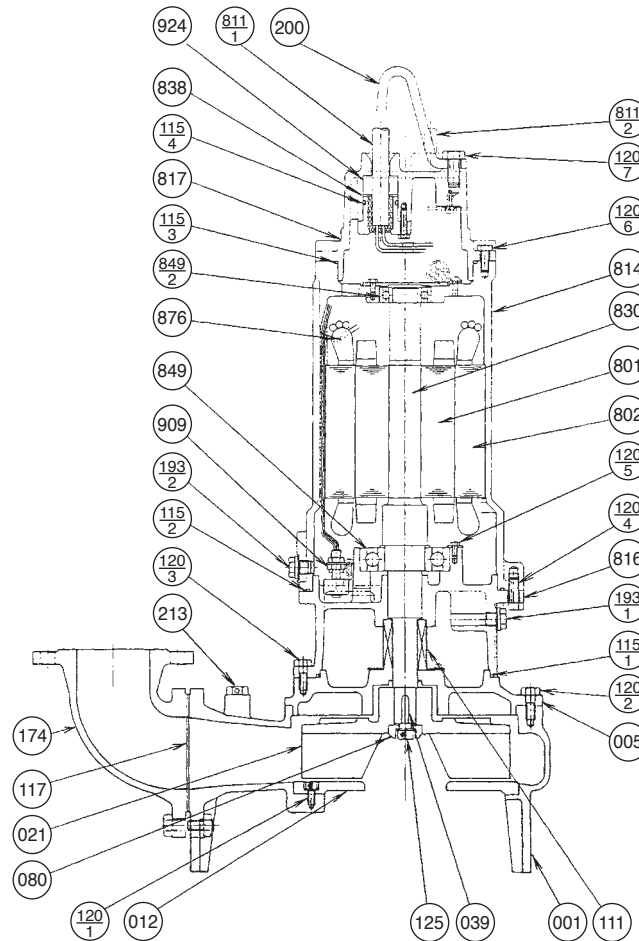

PART NO.	PART NAME	MATERIAL	ASTM, AISI CODE	NO. FOR 1 UNIT
001	CASING	CAST IRON	A48 Class 30	1
005	INTERMEDIATE CASING	CAST IRON	A48 Class 30	1
†012	SUCTION COVER	CAST IRON	A48 Class 30	1
†021	IMPELLER	CAST IRON	A48 Class 30	1
039	KEY	420 STAINLESS	AISI420	1
080	BUSHING	STEEL	A283 Grade D	1
†111	MECHANICAL SEAL	—		1 SET
†115-1	O-RING	RUBBER (NBR)		1
†115-2	O-RING	RUBBER (NBR)		1
†115-3	O-RING	RUBBER (NBR)		1
†115-4	O-RING	RUBBER (NBR)		2
†117	GASKET			1
120-1	BOLT	304 STAINLESS	AISI304	4
120-2	BOLT	304 STAINLESS	AISI304	8
120-3	BOLT	304 STAINLESS	AISI304	4
120-4	BOLT	304 STAINLESS	AISI304	4
120-5	BOLT	304 STAINLESS	AISI304	3
120-6	BOLT	304 STAINLESS	AISI304	4
120-7	BOLT	304 STAINLESS	AISI304	2
125	BOLT	304 STAINLESS	AISI304	1

PART NO.	PART NAME	MATERIAL	ASTM, AISI CODE	NO. FOR 1 UNIT
174	DISCHARGE ELBOW	CAST IRON	A48 Class 30	1
193-1	PLUG	304 STAINLESS	AISI304	1
193-2	PLUG	304 STAINLESS	AISI304	1
200	LIFTING HANGER	STEEL	A283 Grade D	1
213	AIR VENT VALVE	BRASS	B36 No. 272	1
801	ROTOR	—		1
802	STATOR	—		1
811-1	POWER CABLE	—		1
811-2	CONTROL CABLE	—		1
814	MOTOR COVER	CAST IRON	A48 Class 30	1
816	BRACKET	CAST IRON	A48 Class 30	1
817	BRACKET	CAST IRON	A48 Class 30	1
830	SHAFT	403 STAINLESS	AISI403	1
838	WASHER	304 STAINLESS	AISI304	2
†849-1	BALL BEARING	—		1
†849-2	BALL BEARING	—		1
876	MOTOR PROTECTOR	—		3
909	LEAKAGE DETECTOR	—		1
924	PACKING	RUBBER (NBR)		2

Motors are purchased as a complete unit
 †: Recommended spare parts

Sectional View

Project: _____ Model: _____ Chk'd: _____ Date: _____

7½ to 10HP

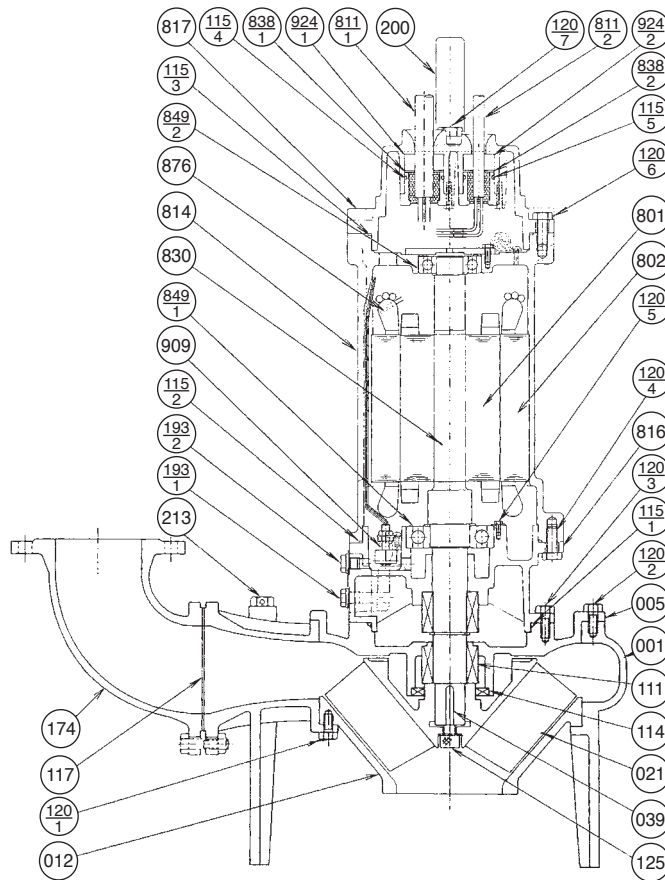

PART NO.	PART NAME	MATERIAL	ASTM, AISI CODE	NO. FOR 1 UNIT	PART NO.	PART NAME	MATERIAL	ASTM, AISI CODE	NO. FOR 1 UNIT
001	CASING	CAST IRON	A48 Class 30	1	174	DISCHARGE ELBOW	CAST IRON	A48 Class 30	1
005	INTERMEDIATE CASING	CAST IRON	A48 Class 30	1	193-1	PLUG	304 STAINLESS	AISI304	1
†012	SUCTION COVER	CAST IRON	A48 Class 30	1	193-2	PLUG	304 STAINLESS	AISI304	1
†021	IMPELLER	CAST IRON	A48 Class 30	1	200	LIFTING HANGER	STEEL	A283 Grade D	1
039	KEY	420 STAINLESS	AISI420	1	213	AIR VENT VALVE	BRASS	B36 No. 272	1
†111	MECHANICAL SEAL	—		1 SET	801	ROTOR	—		1
†114	OIL SEAL	RUBBER (NBR)		1	802	STATOR	—		1
†115-1	O-RING	RUBBER (NBR)		1	811-1	POWER CABLE	—		1
†115-2	O-RING	RUBBER (NBR)		1	811-2	CONTROL CABLE	—		1
†115-3	O-RING	RUBBER (NBR)		1	814	MOTOR COVER	CAST IRON	A48 Class 30	1
†115-4	O-RING	RUBBER (NBR)		1	816	BRACKET	CAST IRON	A48 Class 30	1
†115-5	O-RING	RUBBER (NBR)		1	817	BRACKET	CAST IRON	A48 Class 30	1
†117	GASKET			1	830	SHAFT	420J2 STAINLESS	AISI420	1
120-1	BOLT	304 STAINLESS	AISI304	4	838-1	WASHER	304 STAINLESS	AISI304	1
120-2	BOLT	304 STAINLESS	AISI304	8	838-2	WASHER	304 STAINLESS	AISI304	1
120-3	BOLT	304 STAINLESS	AISI304	4	†849-1	BALL BEARING	—		1
120-4	BOLT	304 STAINLESS	AISI304	6	†849-2	BALL BEARING	—		1
120-5	BOLT	304 STAINLESS	AISI304	3	876	MOTOR PROTECTOR	—		3
120-6	BOLT	304 STAINLESS	AISI304	4	909	LEAKAGE DETECTOR	—		1
120-7	BOLT	304 STAINLESS	AISI304	2	924-1	PACKING	RUBBER (NBR)		1
125	BOLT	304 STAINLESS	AISI304	1	924-2	PACKING	RUBBER (NBR)		1

Motors are purchased as a complete unit

†: Recommended spare parts

Sectional View

Project: _____ Model: _____ Chk'd: _____ Date: _____

15 to 30HP

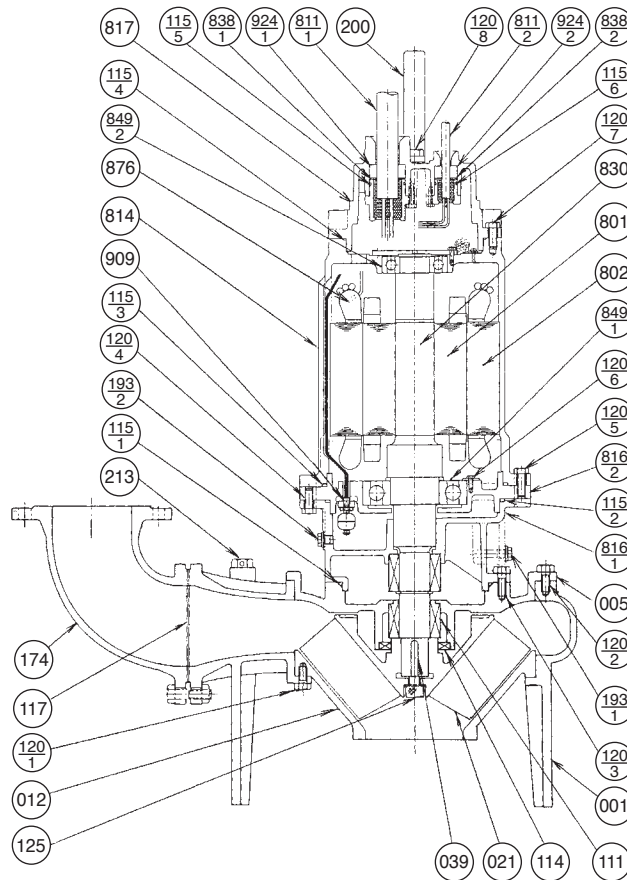

PART NO.	PART NAME	MATERIAL	ASTM, AISI CODE	NO. FOR 1 UNIT
001	CASING	CAST IRON	A48 Class 30	1
005	INTERMEDIATE CASING	CAST IRON	A48 Class 30	1
†012	SUCTION COVER	CAST IRON	A48 Class 30	1
†021	IMPELLER	CAST IRON	A48 Class 30	1
039	KEY	420 STAINLESS	AISI420	1
†111	MECHANICAL SEAL	—		1 SET
†114	OIL SEAL	RUBBER (NBR)		1
†115-1	O-RING	RUBBER (NBR)		1
†115-2	O-RING	RUBBER (NBR)		1
†115-3	O-RING	RUBBER (NBR)		1
†115-4	O-RING	RUBBER (NBR)		1
†115-5	O-RING	RUBBER (NBR)		1
†115-6	O-RING	RUBBER (NBR)		1
†117	GASKET			1
120-1	BOLT	304 STAINLESS	AISI304	4
120-2	BOLT	304 STAINLESS	AISI304	8
120-3	BOLT	304 STAINLESS	AISI304	4
120-4	BOLT	304 STAINLESS	AISI304	6
120-5	BOLT	304 STAINLESS	AISI304	6
120-6	BOLT	304 STAINLESS	AISI304	3
120-7	BOLT	304 STAINLESS	AISI304	6
120-8	BOLT	304 STAINLESS	AISI304	2
125	BOLT	304 STAINLESS	AISI304	1

PART NO.	PART NAME	MATERIAL	ASTM, AISI CODE	NO. FOR 1 UNIT
174	DISCHARGE ELBOW	CAST IRON	A48 Class 30	1
193-1	PLUG	304 STAINLESS	AISI304	1
193-2	PLUG	304 STAINLESS	AISI304	1
200	LIFTING HANGER	STEEL	A283 Grade D	1
213	AIR VENT VALVE	BRASS	B36 No. 272	1
801	ROTOR	—		1
802	STATOR	—		1
811-1	POWER CABLE	—		1
811-2	CONTROL CABLE	—		1
814	MOTOR COVER	CAST IRON	A48 Class 30	1
816-1	BRACKET	CAST IRON	A48 Class 30	1
816-2	BRACKET	CAST IRON	A48 Class 30	1
817	BRACKET	CAST IRON	A48 Class 30	1
830	SHAFT	420J2 STAINLESS	AISI420	1
838-1	WASHER	304 STAINLESS	AISI304	1
838-2	WASHER	304 STAINLESS	AISI304	1
†849-1	BALL BEARING	—		1
†849-2	BALL BEARING	—		1
876	MOTOR PROTECTOR	—		3
909	LEAKAGE DETECTOR	—		1
924-1	PACKING	RUBBER (NBR)		1
924-2	PACKING	RUBBER (NBR)		1

Motors are purchased as a complete unit
 †: Recommended spare parts

Sectional View

Project:

Model:

Chk'd:

Date:

**40 to 60HP
100DLFU**

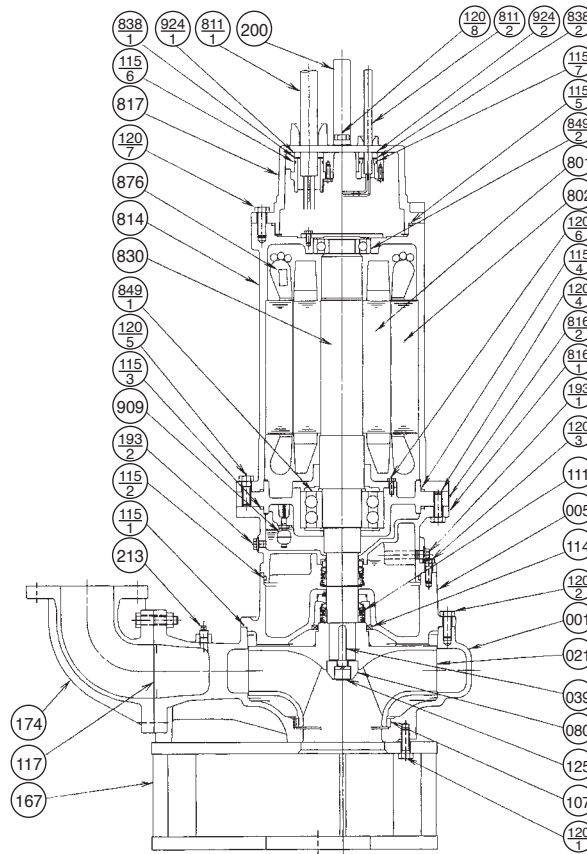

PART NO.	PART NAME	MATERIAL	ASTM, AISI CODE	NO. FOR 1 UNIT	PART NO.	PART NAME	MATERIAL	ASTM, AISI CODE	NO. FOR 1 UNIT
001	CASING	CAST IRON	A48 Class 30	1	125	BOLT	304 STAINLESS	AISI304	1
005	INTERMEDIATE CASING	CAST IRON	A48 Class 30	1	*167	BASE	STEEL	A283 Grade D	1
†021	IMPELLER	CAST IRON	A48 Class 30	1	174	DISCHARGE ELBOW	CAST IRON	A48 Class 30	1
039	KEY	420 STAINLESS	AISI420	1	193-1	PLUG	304 STAINLESS	AISI304	1
080	BUSHING	304 STAINLESS	AISI 304	1	193-2	PLUG	304 STAINLESS	AISI304	1
†107	WEARING RING	304 STAINLESS	AISI 304	1	200	LIFTING HANGER	STEEL	A283 Grade D	1
†111	MECHANICAL SEAL	—		1 SET	213	AIR VENT VALVE	BRASS	B36 No. 272	1
†114	OIL SEAL	RUBBER (NBR)		1	801	ROTOR	—		1
†115-1	O-RING	RUBBER (NBR)		1	802	STATOR	—		1
†115-2	O-RING	RUBBER (NBR)		1	811-1	POWER CABLE	—		2
†115-3	O-RING	RUBBER (NBR)		1	811-2	CONTROL CABLE	—		1
†115-4	O-RING	RUBBER (NBR)		1	814	MOTOR COVER	CAST IRON	A48 Class 30	1
†115-5	O-RING	RUBBER (NBR)		1	816-1	BRACKET	CAST IRON	A48 Class 30	1
†115-6	O-RING	RUBBER (NBR)		2	816-2	BRACKET	CAST IRON	A48 Class 30	1
†115-7	O-RING	RUBBER (NBR)		1	817	BRACKET	CAST IRON	A48 Class 30	1
†117	GASKET			1	830	SHAFT	420J2 STAINLESS	AISI420	1
120-1	BOLT	304 STAINLESS	AISI304	8	838-1	WASHER	304 STAINLESS	AISI304	2
120-2	BOLT	304 STAINLESS	AISI304	8	838-2	WASHER	304 STAINLESS	AISI304	1
120-3	BOLT	304 STAINLESS	AISI304	8	†849-1	BALL BEARING	—		1 SET
120-4	BOLT	304 STAINLESS	AISI304	8	†849-2	BALL BEARING	—		1
120-5	BOLT	304 STAINLESS	AISI304	6	876	MOTOR PROTECTOR	—		3
120-6	BOLT	304 STAINLESS	AISI304	4	909	LEAKAGE DETECTOR	—		1
120-7	BOLT	304 STAINLESS	AISI304	6	924-1	PACKING	RUBBER (NBR)		2
120-8	BOLT	304 STAINLESS	AISI304	2	924-2	PACKING	RUBBER (NBR)		1

Motors are purchased as a complete unit

†: Recommended spare parts

*: Option for hard-piped installations

Sectional View

Project:

Model:

Chk'd:

Date:

**40 to 60HP
150DLFU
200DLFU
250DLFU
300DLFU**

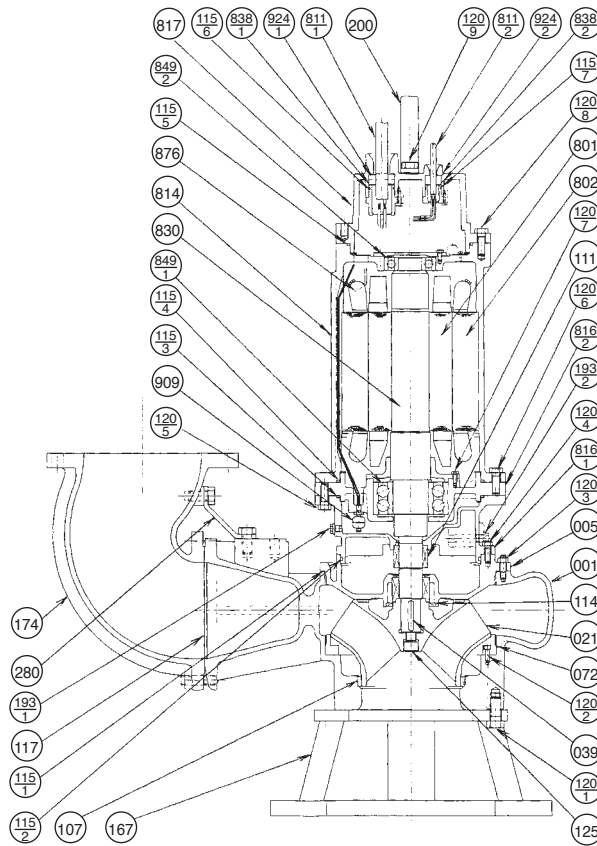

PART NO.	PART NAME	MATERIAL	ASTM, AISI CODE	NO. FOR 1 UNIT
001	CASING	CAST IRON	A48 Class 30	1
005	INTERMEDIATE CASING	CAST IRON	A48 Class 30	1
†021	IMPELLER	DUCTILE IRON	A536 60-40-18	1
039	KEY	420 STAINLESS	AISI420	1
†072	SIDE RING	CAST IRON	A48 Class 30	1
†107	WEARING RING	304 STAINLESS	AISI304	1
†111	MECHANICAL SEAL	—		1 SET
†114	OIL SEAL	RUBBER (NBR)		1
†115-1	O-RING	RUBBER (NBR)		1
†115-2	O-RING	RUBBER (NBR)		1
†115-3	O-RING	RUBBER (NBR)		1
†115-4	O-RING	RUBBER (NBR)		1
†115-5	O-RING	RUBBER (NBR)		1
†115-6	O-RING	RUBBER (NBR)		2
†115-7	O-RING	RUBBER (NBR)		1
†117	GASKET			1
120-1	BOLT	304 STAINLESS	AISI304	3/4
120-2	BOLT	304 STAINLESS	AISI304	4
120-3	BOLT	304 STAINLESS	AISI304	8
120-4	BOLT	304 STAINLESS	AISI304	4
120-5	BOLT	304 STAINLESS	AISI304	8
120-6	BOLT	304 STAINLESS	AISI304	8
120-7	BOLT	304 STAINLESS	AISI304	4
120-8	BOLT	304 STAINLESS	AISI304	6
120-9	BOLT	304 STAINLESS	AISI304	2

PART NO.	PART NAME	MATERIAL	ASTM, AISI CODE	NO. FOR 1 UNIT
125	BOLT	304 STAINLESS	AISI304	1
*167	BASE	STEEL	A283 Grade D	1
174	DISCHARGE ELBOW	CAST IRON	A48 Class 30	1
193-1	PLUG	304 STAINLESS	AISI304	1
193-2	PLUG	304 STAINLESS	AISI304	1
200	LIFTING HANGER	STEEL	A283 Grade D	1
280	ELBOW SUPPORT	STEEL	A283 Grade D	2
801	ROTOR	—		1
802	STATOR	—		1
811-1	POWER CABLE	—		2
811-2	CONTROL CABLE	—		1
814	MOTOR COVER	CAST IRON	A48 Class 30	1
816-1	BRACKET	CAST IRON	A48 Class 30	1
816-2	BRACKET	CAST IRON	A48 Class 30	1
817	BRACKET	CAST IRON	A48 Class 30	1
830	SHAFT	420J2 STAINLESS	AISI420	1
838-1	WASHER	304 STAINLESS	AISI304	2
838-2	WASHER	304 STAINLESS	AISI304	1
†849-1	BALL BEARING	—		1 SET
†849-2	BALL BEARING	—		1
876	MOTOR PROTECTOR	—		3
909	LEAKAGE DETECTOR	—		1
924-1	PACKING	RUBBER (NBR)		2
924-2	PACKING	RUBBER (NBR)		1

Motors are purchased as a complete unit
 †: Recommended spare parts
 *: Option for hard-piped installations