

**Contents**

**Model**

80DMLEU62.2	100DMLEU63.7	150DMLEU65.5
80DMLEU63.7	100DMLEU65.5	150DMLEU67.5
80DMLEU65.5	100DMLEU67.5	150DMLEU611
80DMLEU67.5	100DMLEU611	150DMLEU615
80DMLEU611	100DMLEU615	150DMLEU622
80DMLEU615	100DMLEU622	
80DMLEU622		

<b>Section</b>	<b>Page</b>
Specifications	2-138
Selection Chart	2-141
Performance Curves	2-142
Dimensions	2-146
Sectional View	2-150
QDC Information	2-278
Motor Data	2-153
motor electrical specifications	
cable data	
wiring diagrams	
motor electrical data	

**Model Designation**

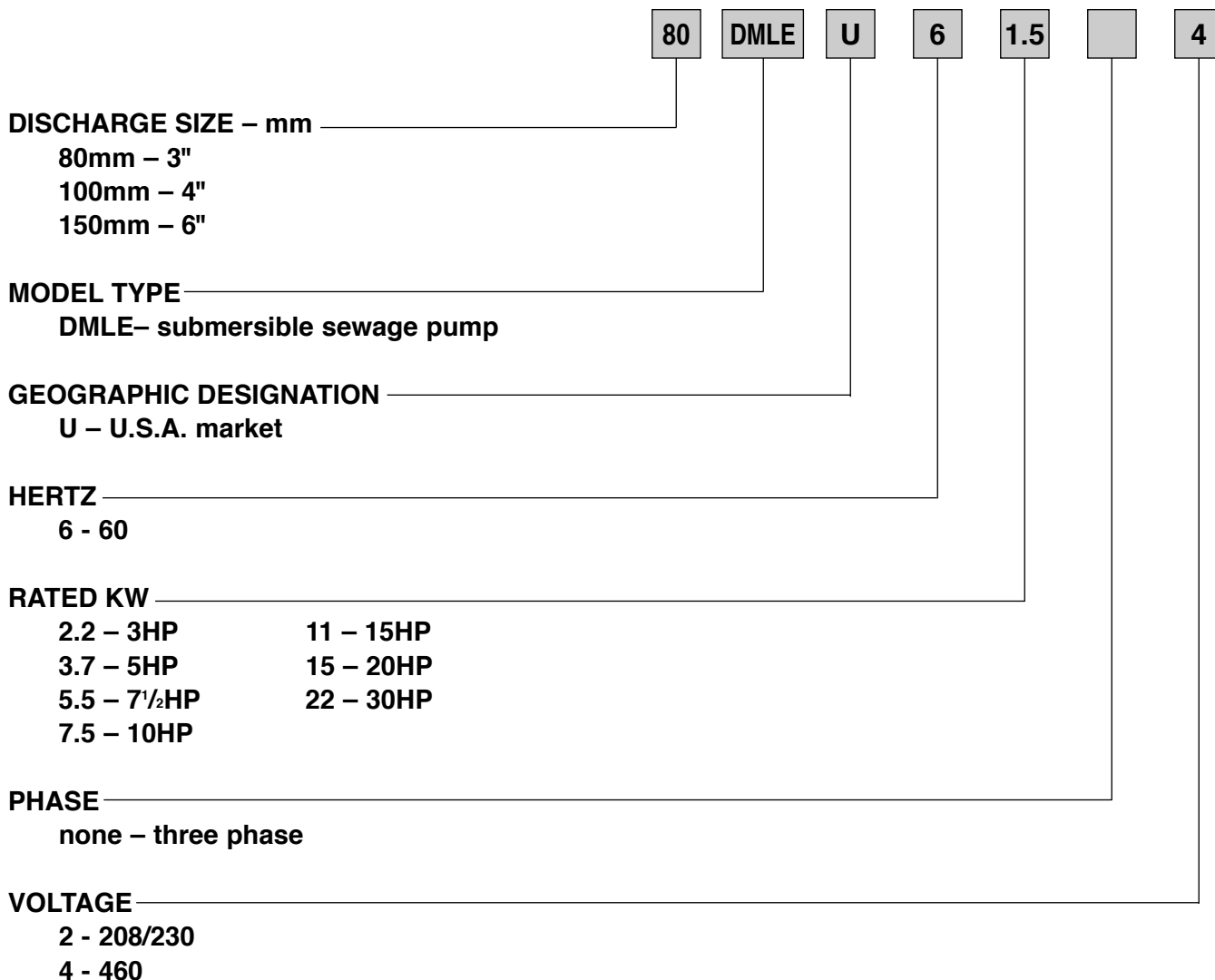

**Specifications**

**Model DMLEU**  
Specifications

	Standard	Optional
Size	3, 4, 6 inch	
Range of HP	3 to 30HP	
Range of Performance	Capacity: 55 to 1345 GPM Head: 12 to 136 feet	
<b>Limitation</b> Maximum Water Temperature	104°F (40°C)	
<b>Synchronous Speed</b>	1800 RPM	
<b>Materials</b> Casing Impeller Shaft Motor Frame Fastener	Cast Iron Cast Iron 403 Stainless Steel Cast Iron 304 Stainless Steel	
<b>Mechanical Seal</b> Material – Upper Side Material – Lower Side Impeller Type Bearing Motor Three Phase Service Factor Motor Protection Accessories	Double Mechanical Seal Carbon/Ceramic Silicon Carbide/Silicon Carbide Non-clog single channel enclosed Pre-lubricated Ball Bearing Air-filled, dry submersible, Class F Insulation 208/230 or 460V 1.15 Built-in Auto cut (3HP model) Thermal Detector – Klixons Mechanical seal leak detector – internal oil probe Submersible cable 33 ft.	66 ft. QDC System

**Specifications**

**A. General:**

Provide submersible sewage pumps suitable for continuous duty operation underwater without loss of watertight integrity to a depth of 65 feet. If mounted on a guide rail system, design shall be such that the pump will be automatically connected to the discharge piping when lowered into place on the discharge connection. The pump shall be easily removable for inspection or service, requiring no bolts, nuts, or other fasteners to be disconnected, or the need for personnel to enter the wet well. The motor and pump shall be designed, manufactured, and assembled by the same manufacturer.

**B. Manufacturer:**

EBARA International Corporation

**C. Pump Characteristics:**

Pumps shall conform to the following requirements:

Number of units	
Design flow (gpm)	
Design TDH (ft)	
Minimum shut off head (ft)	
RPM	1800
Maximum HP	
Minimum efficiency at design (%)	
Minimum power factor at design (%)	
Voltage/HZ	208/230V, 460V / 60
Phase	

**D. Pump Construction:**

All major parts of the pumping unit(s) including casing, impeller, motor frame and discharge elbow shall be manufactured from gray cast iron, ASTM A-48 Class 30. Castings shall have smooth surfaces devoid of blow holes or other casting irregularities. Casing design shall be centerline discharge with a large radius on the cut water to prevent clogging. Units shall be furnished with a discharge elbow and 125 lb. flat face ANSI flange. All exposed bolts and nuts shall be 304 stainless steel. All mating surfaces of major components shall be machined and fitted with NBR O-rings where watertight sealing is required. Machining and fitting shall be such that sealing is accomplished by automatic compression of O-rings in two planes and O-ring contact is made on four surfaces without the requirement of specific torque limits. Internal and external surfaces are prepared to SPPC-VISI-SP-3-63 then coated with a zinc-chromate primer. The external surfaces are then coated with a Modified epoxy resin (Product name: Metal Grip Black\_Mod) by air spray.

Impeller shall be single vane enclosed design. The impeller design shall include back pump out vanes to reduce the pressure and entry of foreign materials into the mechanical seal area. The inlet edge of the impeller vanes shall be angled toward the impeller periphery so as to facilitate the release of objects that might otherwise clog the pump. Impellers shall be direct connected to the motor shaft with a slip fit, key driven, and secured with an impeller bolt. The unit shall include a replaceable casing wear ring at the pump suction to maintain working clearances and hydraulic efficiencies.

Double mechanical seals operating in an oil bath shall be provided on all units. The oil filled seal chamber shall be designed to prevent over-filling and include an anti-vortexing vane to insure proper lubrication of both seal faces. Lower face materials shall be silicon carbide vs. silicon carbide, upper faces carbon vs. ceramic, NBR elastomers, and 304SS hardware. Seal system shall not rely on pumping medium for lubrication.

---

**Specifications**

---

**E. Motor Construction:**

The pump motor shall be an air filled induction type with a squirrel cage rotor, shell type design, built to NEMA MG-1, Design B specifications. Stator windings shall be copper, insulated with moisture resistant Class F insulation, rated for 311 F. The stator shall be dipped and baked in Class F varnish and heat shrunk fitted into the stator housing. Rotor bars and short circuit rings shall be manufactured of cast aluminum. Motor shaft shall be one piece AISI403 material, rotating on two permanently lubricated ball bearings designed for a minimum B-10 life of 60,000 hours. Motor service factor shall be 1.15 and capable of up to 20 starts per hour. The motor shall be designed for continuous duty pumping at a maximum sump temperature of 104 F. Voltage and frequency tolerances shall be a maximum 10 / 5% respectively. For 3 HP units, motor protection shall be provided by an auto-cut device located directly over the windings to provide protection from single phasing, low voltage, phase imbalance, locked rotor, and no load or run dry conditions. Motor over temperature protection shall be provided by miniature thermal protectors embedded in the windings. An electrical probe shall be provided in the oil chamber for detecting the presence of water. The probe shall be mounted internally to the motor housing. A solid state device mounted in the pump control panel or in a separate enclosure shall send a low voltage, low amperage signal to the probe. If water enters the oil chamber, the probe shall close an electrical circuit and energize a warning device. Motor shall be non-overloading over the entire performance curve and be able to operate at full load intermittently while unsubmerged without damage to the unit.

Power cable jacket shall be manufactured of an oil resistant chloroprene rubber material, designed for submerged applications. Cable shall be watertight to a depth of at least 65'. Cable entry shall be composed of a one piece, vulcanized, three way mechanical sealing system with a thick molded shoulder with increasing cable diameters to resist fatigue from bending forces. The molded shoulder, acts as the primary and secondary sealing points. This system shall also prevent leakage into the motor housing due to capillary action through the insulation if the cable is damaged or cut. A metallic plate shall be utilized to clamp the entry system to the motor housing.

**F. Guide Rail system:**

Design shall include two (2) 304SS schedule 40 guide rails sized to mount directly to the quick discharge connector, QDC, at the floor of the wet well and to a guide rail bracket at the top of the wetwell below the hatch opening, (refer to project drawings). Intermediate guide brackets are recommended for rail lengths over 15 feet.

Guide rails are not part of the pump package and shall be supplied by others.

The QDC shall be manufactured of cast iron, ASTM A48 Class 30. It shall be designed to adequately support the guide rails, discharge piping, and pumping unit under both static and dynamic loading conditions with support legs that are suitable for anchoring it to the wetwell floor. The face of the inlet QDC flange shall be perpendicular to the floor of the wetwell. The discharge flange of the QDC shall conform to ANSI B16.1 Class 125.

The pump design shall include an integral self-aligning sliding bracket. Sealing of the pumping unit to the QDC shall be accomplished by a single, linear, downward motion of the pump. The entire weight of the pump unit shall be guided to and wedged tightly against the inlet flange of the QDC, making metal to metal contact with the pump discharge forming a seal without the use of bolts, gaskets or O-rings.

A stainless steel lifting chain of adequate length for removing and installing the pump unit is recommended. The chain shall have a round link with a 2-1/4" inside diameter every two feet. This link will allow for a sliding pinch bar through the link to pick the chain, more than once if necessary, at multiple intervals during pump removal and installation.

Selection Chart

Model DMLEU  
Selection chart

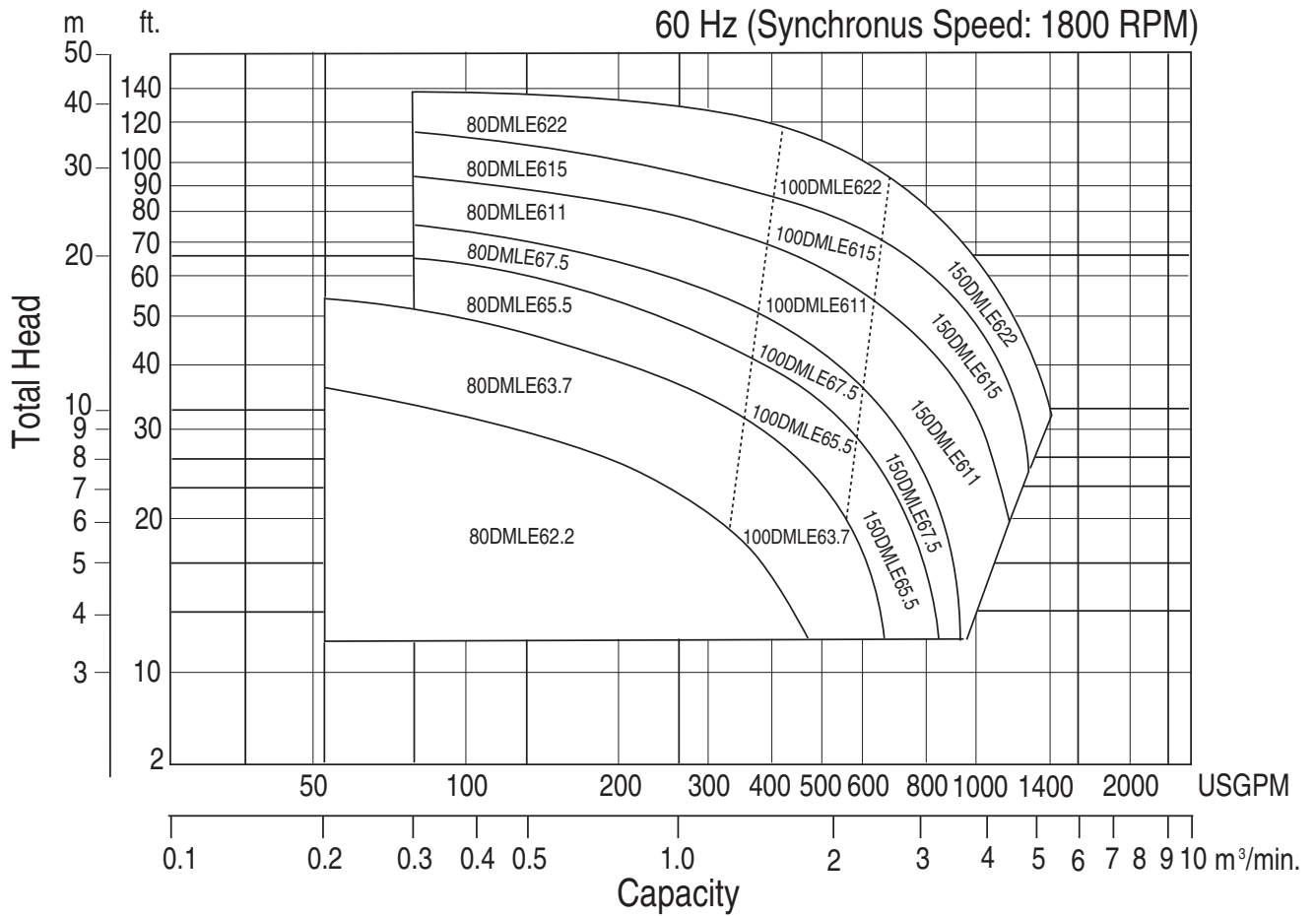

**Performance Curves**

Project: \_\_\_\_\_ GPM: \_\_\_\_\_ TDH: \_\_\_\_\_ EFF: \_\_\_\_\_ HP: \_\_\_\_\_ Chk'd: \_\_\_\_\_ Date: \_\_\_\_\_

**80DMLE62.2 (3HP)**

**Synchronous Speed: 1800 RPM**

**3 inch Discharge**

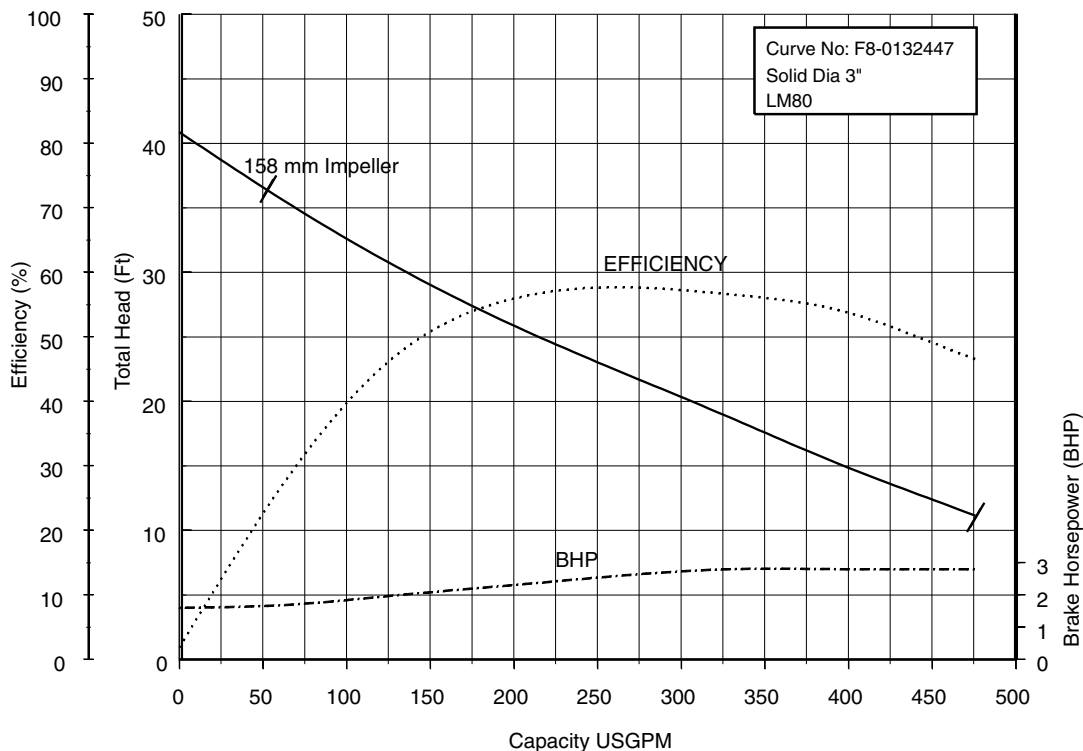

**80, 100DMLE63.7 (5HP)**

**Synchronous Speed: 1800 RPM**

**3, 4 inch Discharge**

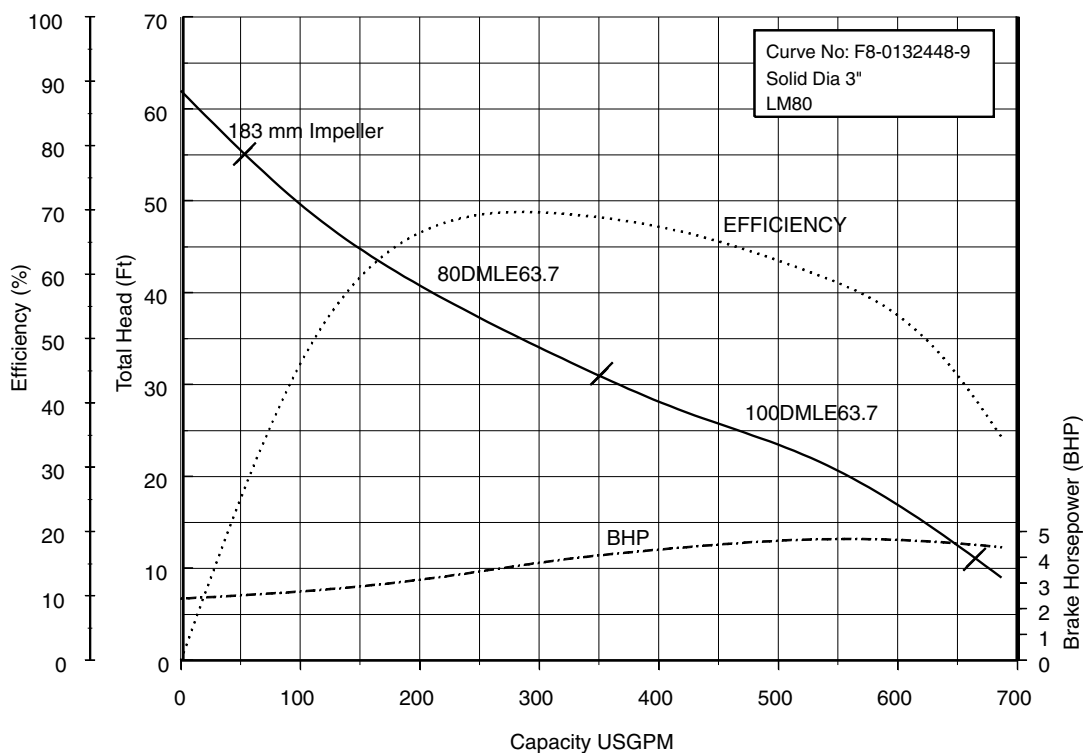

**Performance Curves**

Project: \_\_\_\_\_ GPM: \_\_\_\_\_ TDH: \_\_\_\_\_ EFF: \_\_\_\_\_ HP: \_\_\_\_\_ Chk'd: \_\_\_\_\_ Date: \_\_\_\_\_

**80, 100, 150DMLE65.5 (7.5HP) Synchronous Speed: 1800 RPM 3, 4, 6 inch Discharge**

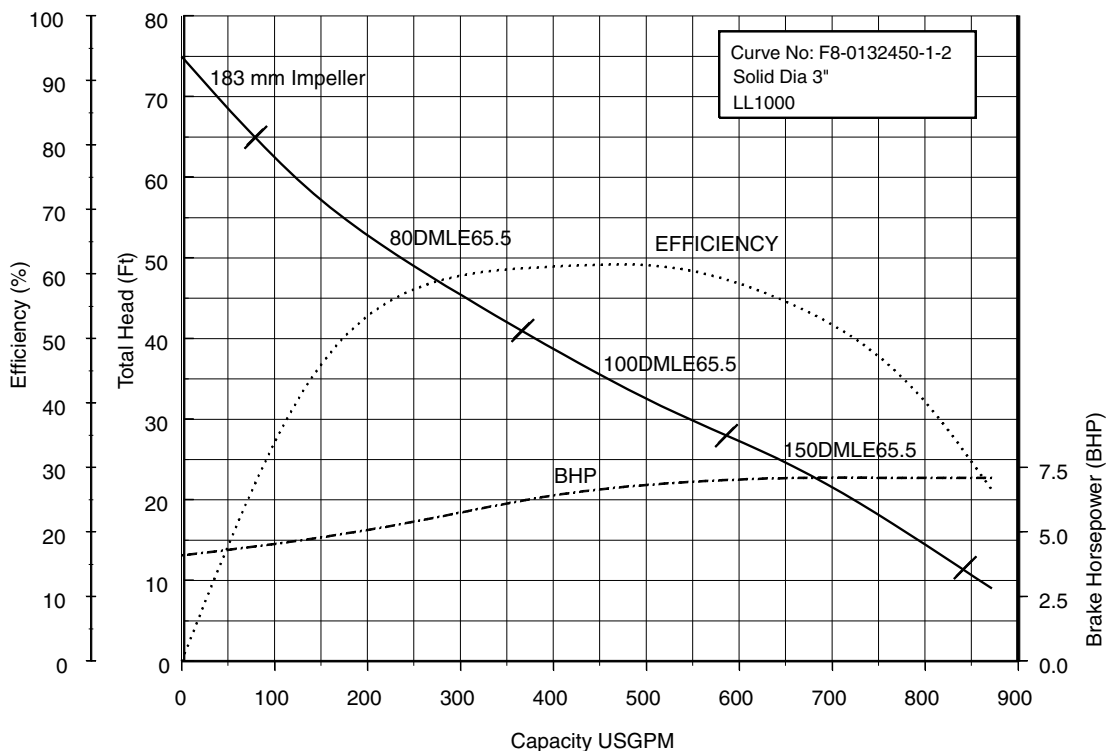

**80, 100, 150DMLE67.5 (10HP) Synchronous Speed: 1800 RPM 3, 4, 6 inch Discharge**

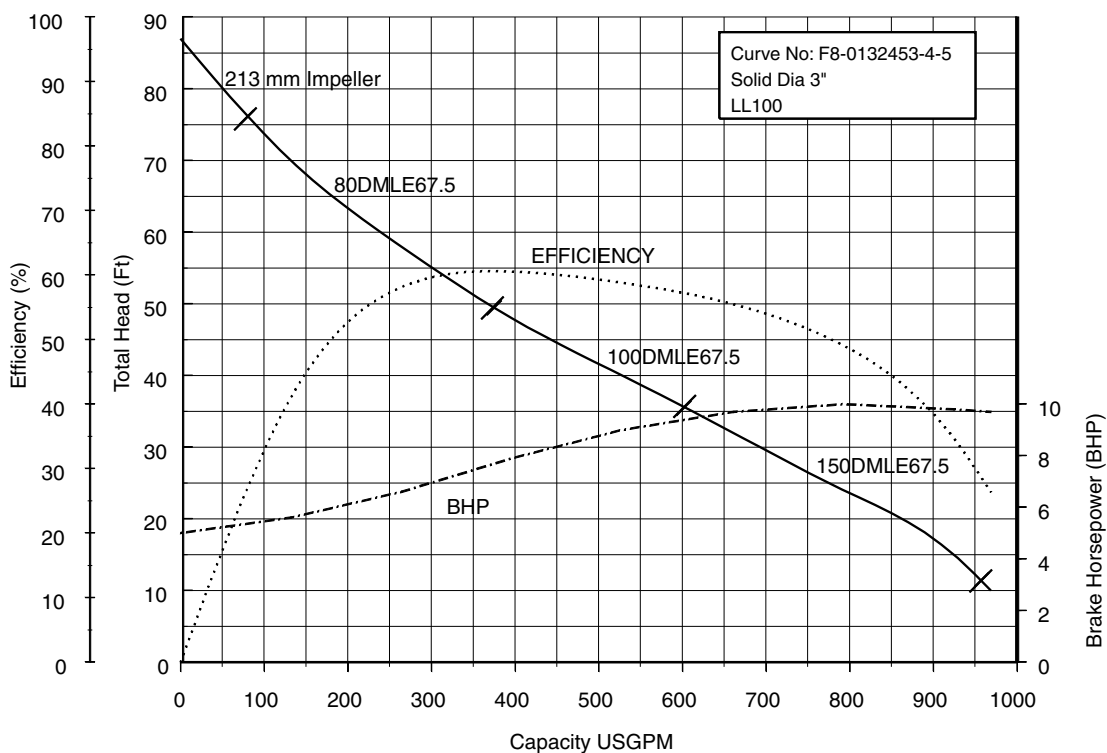



**Performance Curves**

Project: \_\_\_\_\_ GPM: \_\_\_\_\_ TDH: \_\_\_\_\_ EFF: \_\_\_\_\_ HP: \_\_\_\_\_ Chk'd: \_\_\_\_\_ Date: \_\_\_\_\_

**80, 100, 150DMLE611 (15HP) Synchronous Speed: 1800 RPM 3, 4, 6 inch Discharge**

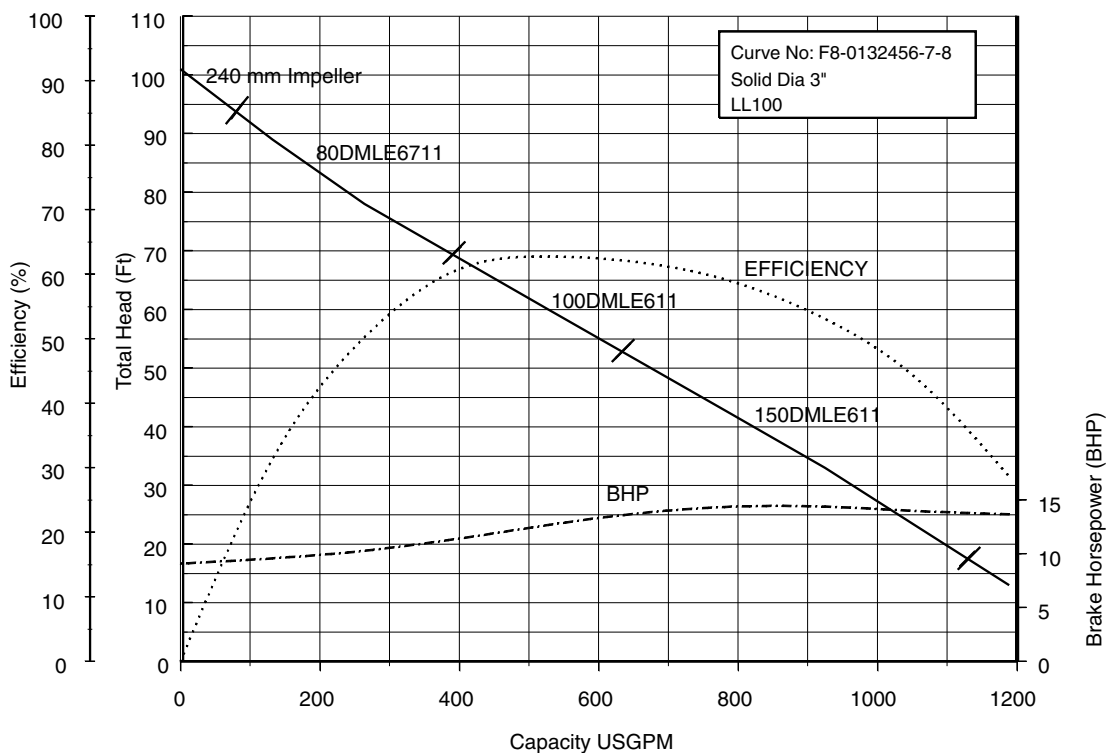

**80, 100, 150DMLE615 (20HP) Synchronous Speed: 1800 RPM 3, 4, 6 inch Discharge**

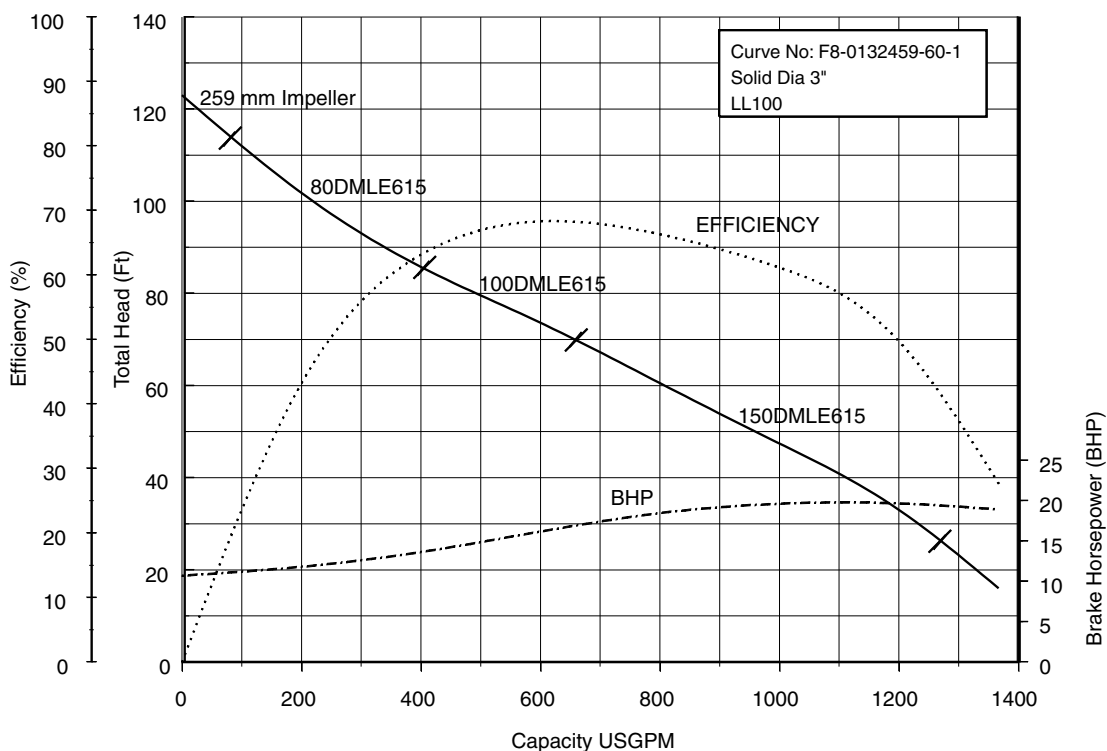

**Performance Curves**

Project: \_\_\_\_\_ GPM: \_\_\_\_\_ TDH: \_\_\_\_\_ EFF: \_\_\_\_\_ HP: \_\_\_\_\_ Chk'd: \_\_\_\_\_ Date: \_\_\_\_\_

**80, 100, 150DMLE622 (30HP) Synchronous Speed: 1800 RPM 3, 4, 6 inch Discharge**

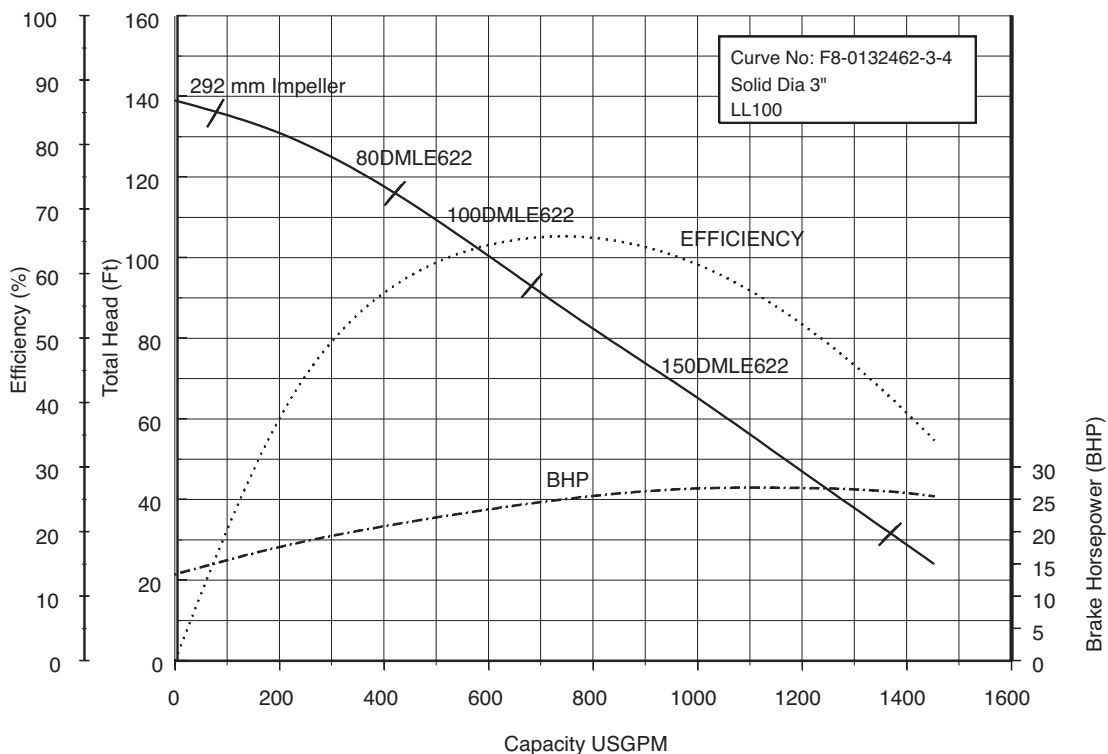

**Dimensions**

Project: \_\_\_\_\_ Model: \_\_\_\_\_ Chk'd: \_\_\_\_\_ Date: \_\_\_\_\_

**Model DMLEU**

80DMLEU, 3 to 30HP  
 100DMLEU, 5 to 30 HP  
 150DMLEU, 7.5 to 30HP

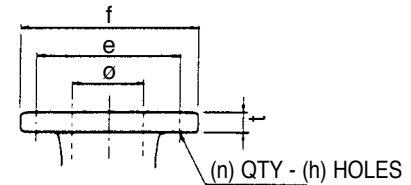
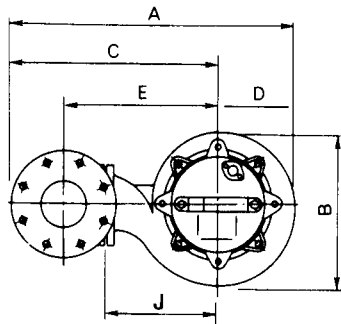
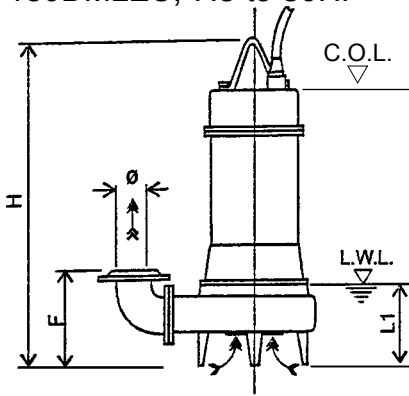

**Flange (ANSI 125 PSI F.F)**

inch					
ø	e	f	t	n	h
3	6	7 <sup>1</sup> / <sub>2</sub>	<sup>3</sup> / <sub>4</sub>	4	<sup>3</sup> / <sub>4</sub>
4	7 <sup>1</sup> / <sub>2</sub>	9	<sup>15</sup> / <sub>16</sub>	8	<sup>3</sup> / <sub>4</sub>
6	9 <sup>1</sup> / <sub>2</sub>	11	1	8	<sup>3</sup> / <sub>4</sub>

mm					
ø	e	f	t	n	h
80	150	185	19	4	19
100	175	210	20	8	19
150	240	280	22	8	19

**Dimensions: inch**

PHASE	SIZE ø	MODEL	OUTPUT		PUMP & MOTOR									WEIGHT Lb
			kW	HP	A	B	C	D	E	F	H	J	L1	
THREE	3	80DMLEU62.2	2.2	3	21	12 <sup>5</sup> / <sub>8</sub>	14 <sup>7</sup> / <sub>8</sub>	6 <sup>3</sup> / <sub>16</sub>	11 <sup>1</sup> / <sub>4</sub>	11 <sup>3</sup> / <sub>4</sub>	26 <sup>5</sup> / <sub>16</sub>	8 <sup>1</sup> / <sub>4</sub>	11	176
		80DMLEU63.7	3.7	5	21	12 <sup>5</sup> / <sub>8</sub>	14 <sup>7</sup> / <sub>8</sub>	6 <sup>3</sup> / <sub>16</sub>	11 <sup>1</sup> / <sub>4</sub>	11 <sup>3</sup> / <sub>4</sub>	28 <sup>5</sup> / <sub>8</sub>	8 <sup>1</sup> / <sub>4</sub>	11	192
		80DMLEU65.5	5.5	7.5	25 <sup>3</sup> / <sub>16</sub>	15	17 <sup>13</sup> / <sub>16</sub>	7 <sup>3</sup> / <sub>8</sub>	14 <sup>3</sup> / <sub>16</sub>	13 <sup>1</sup> / <sub>8</sub>	32 <sup>7</sup> / <sub>16</sub>	10 <sup>1</sup> / <sub>16</sub>	12 <sup>3</sup> / <sub>16</sub>	260
		80DMLEU67.5	7.5	10	25 <sup>3</sup> / <sub>16</sub>	15	17 <sup>13</sup> / <sub>16</sub>	7 <sup>3</sup> / <sub>8</sub>	14 <sup>3</sup> / <sub>16</sub>	13 <sup>1</sup> / <sub>8</sub>	32 <sup>7</sup> / <sub>16</sub>	10 <sup>1</sup> / <sub>16</sub>	12 <sup>3</sup> / <sub>16</sub>	271
		80DMLEU611	11	15	28 <sup>7</sup> / <sub>8</sub>	17 <sup>15</sup> / <sub>16</sub>	20 <sup>3</sup> / <sub>16</sub>	8 <sup>11</sup> / <sub>16</sub>	16 <sup>9</sup> / <sub>16</sub>	13 <sup>3</sup> / <sub>4</sub>	36 <sup>15</sup> / <sub>16</sub>	12 <sup>3</sup> / <sub>8</sub>	12 <sup>15</sup> / <sub>16</sub>	346
		80DMLEU615	15	20	28 <sup>7</sup> / <sub>8</sub>	17 <sup>15</sup> / <sub>16</sub>	20 <sup>3</sup> / <sub>16</sub>	8 <sup>11</sup> / <sub>16</sub>	16 <sup>9</sup> / <sub>16</sub>	13 <sup>3</sup> / <sub>4</sub>	36 <sup>15</sup> / <sub>16</sub>	12 <sup>3</sup> / <sub>8</sub>	12 <sup>15</sup> / <sub>16</sub>	359
	80DMLEU622	22	30	30 <sup>9</sup> / <sub>16</sub>	19 <sup>9</sup> / <sub>16</sub>	21	9 <sup>5</sup> / <sub>8</sub>	17 <sup>5</sup> / <sub>16</sub>	14 <sup>3</sup> / <sub>16</sub>	40 <sup>3</sup> / <sub>16</sub>	13 <sup>3</sup> / <sub>16</sub>	13 <sup>1</sup> / <sub>16</sub>	492	
	4	100DMLEU63.7	3.7	5	22 <sup>11</sup> / <sub>16</sub>	12 <sup>5</sup> / <sub>8</sub>	16 <sup>9</sup> / <sub>16</sub>	6 <sup>3</sup> / <sub>16</sub>	12 <sup>3</sup> / <sub>8</sub>	12 <sup>5</sup> / <sub>16</sub>	28 <sup>5</sup> / <sub>8</sub>	8 <sup>1</sup> / <sub>4</sub>	11	196
		100DMLEU65.5	5.5	7.5	25 <sup>11</sup> / <sub>16</sub>	15	18 <sup>5</sup> / <sub>16</sub>	7 <sup>3</sup> / <sub>8</sub>	14 <sup>3</sup> / <sub>16</sub>	13 <sup>1</sup> / <sub>8</sub>	32 <sup>7</sup> / <sub>16</sub>	10 <sup>1</sup> / <sub>16</sub>	12 <sup>3</sup> / <sub>16</sub>	267
		100DMLEU67.5	7.5	10	25 <sup>11</sup> / <sub>16</sub>	15	18 <sup>5</sup> / <sub>16</sub>	7 <sup>3</sup> / <sub>8</sub>	14 <sup>3</sup> / <sub>16</sub>	13 <sup>1</sup> / <sub>8</sub>	32 <sup>7</sup> / <sub>16</sub>	10 <sup>1</sup> / <sub>16</sub>	12 <sup>3</sup> / <sub>16</sub>	276
		100DMLEU611	11	15	29 <sup>3</sup> / <sub>8</sub>	17 <sup>15</sup> / <sub>16</sub>	20 <sup>11</sup> / <sub>16</sub>	8 <sup>11</sup> / <sub>16</sub>	16 <sup>9</sup> / <sub>16</sub>	13 <sup>3</sup> / <sub>4</sub>	36 <sup>15</sup> / <sub>16</sub>	12 <sup>3</sup> / <sub>8</sub>	12 <sup>15</sup> / <sub>16</sub>	353
		100DMLEU615	15	20	29 <sup>3</sup> / <sub>8</sub>	17 <sup>15</sup> / <sub>16</sub>	20 <sup>11</sup> / <sub>16</sub>	8 <sup>11</sup> / <sub>16</sub>	16 <sup>9</sup> / <sub>16</sub>	13 <sup>3</sup> / <sub>4</sub>	36 <sup>15</sup> / <sub>16</sub>	12 <sup>3</sup> / <sub>8</sub>	12 <sup>15</sup> / <sub>16</sub>	366
		100DMLEU622	22	30	31 <sup>1</sup> / <sub>8</sub>	19 <sup>9</sup> / <sub>16</sub>	21 <sup>7</sup> / <sub>16</sub>	9 <sup>5</sup> / <sub>8</sub>	17 <sup>5</sup> / <sub>16</sub>	14 <sup>3</sup> / <sub>16</sub>	40 <sup>3</sup> / <sub>16</sub>	13 <sup>3</sup> / <sub>16</sub>	13 <sup>1</sup> / <sub>16</sub>	498
	6	150DMLEU65.5	5.5	7.5	28 <sup>1</sup> / <sub>16</sub>	15	20 <sup>11</sup> / <sub>16</sub>	7 <sup>3</sup> / <sub>8</sub>	15 <sup>3</sup> / <sub>16</sub>	14 <sup>1</sup> / <sub>2</sub>	32 <sup>7</sup> / <sub>16</sub>	10 <sup>1</sup> / <sub>16</sub>	12 <sup>3</sup> / <sub>16</sub>	280
		150DMLEU67.5	7.5	10	28 <sup>1</sup> / <sub>16</sub>	15	20 <sup>11</sup> / <sub>16</sub>	7 <sup>3</sup> / <sub>8</sub>	15 <sup>3</sup> / <sub>16</sub>	14 <sup>1</sup> / <sub>2</sub>	32 <sup>7</sup> / <sub>16</sub>	10 <sup>1</sup> / <sub>16</sub>	12 <sup>3</sup> / <sub>16</sub>	291
150DMLEU611		11	15	31 <sup>3</sup> / <sub>4</sub>	17 <sup>15</sup> / <sub>16</sub>	23 <sup>1</sup> / <sub>16</sub>	8 <sup>11</sup> / <sub>16</sub>	17 <sup>1</sup> / <sub>2</sub>	15 <sup>3</sup> / <sub>16</sub>	36 <sup>15</sup> / <sub>16</sub>	12 <sup>3</sup> / <sub>8</sub>	12 <sup>15</sup> / <sub>16</sub>	366	
150DMLEU615		15	20	31 <sup>3</sup> / <sub>4</sub>	17 <sup>15</sup> / <sub>16</sub>	23 <sup>1</sup> / <sub>16</sub>	8 <sup>11</sup> / <sub>16</sub>	17 <sup>1</sup> / <sub>2</sub>	15 <sup>3</sup> / <sub>16</sub>	36 <sup>15</sup> / <sub>16</sub>	12 <sup>3</sup> / <sub>8</sub>	12 <sup>15</sup> / <sub>16</sub>	379	
150DMLEU622		22	30	33 <sup>7</sup> / <sub>16</sub>	19 <sup>9</sup> / <sub>16</sub>	23 <sup>13</sup> / <sub>16</sub>	9 <sup>5</sup> / <sub>8</sub>	18 <sup>5</sup> / <sub>16</sub>	15 <sup>11</sup> / <sub>16</sub>	40 <sup>3</sup> / <sub>16</sub>	13 <sup>3</sup> / <sub>16</sub>	13 <sup>1</sup> / <sub>16</sub>	511	

**Dimensions: mm**

PHASE	SIZE ø	MODEL	OUTPUT		PUMP & MOTOR									WEIGHT kg
			kW	HP	A	B	C	D	E	F	H	J	L1	
THREE	80	80DMLEU62.2	2.2	3	534	320	378	157	285	298	668	210	279	80
		80DMLEU63.7	3.7	5	534	320	378	157	285	298	727	210	279	87
		80DMLEU65.5	5.5	7.5	640	381	453	188	360	334	824	255	310	118
		80DMLEU67.5	7.5	10	640	381	453	188	360	334	824	255	310	123
		80DMLEU611	11	15	734	455	513	221	420	350	938	315	329	157
		80DMLEU615	15	20	734	455	513	221	420	350	938	315	329	163
	80DMLEU622	22	30	777	497	533	245	440	363	1021	335	332	223	
	100	100DMLEU63.7	3.7	5	577	320	420	157	315	313	727	210	279	89
		100DMLEU65.5	5.5	7.5	653	381	465	188	360	334	824	255	310	121
		100DMLEU67.5	7.5	10	653	381	465	188	360	334	824	255	310	125
		100DMLEU611	11	15	746	455	525	221	420	350	938	315	329	160
		100DMLEU615	15	20	746	455	525	221	420	350	938	315	329	166
		100DMLEU622	22	30	790	497	545	245	440	363	1021	335	332	226
	150	150DMLEU65.5	5.5	7.5	713	381	525	188	385	369	824	255	310	127
		150DMLEU67.5	7.5	10	713	381	525	188	385	369	824	255	310	132
150DMLEU611		11	15	806	455	585	221	445	385	938	315	329	166	
150DMLEU615		15	20	806	455	585	221	445	385	938	315	329	172	
150DMLEU622		22	30	850	497	605	245	465	398	1021	335	332	232	

**Dimensions**

Project: \_\_\_\_\_ Model: \_\_\_\_\_ Chk'd: \_\_\_\_\_ Date: \_\_\_\_\_

**Model DMLEU with Quick Discharge Connector**

80DMLEU62.2

80DMLEU63.7

100DMLEU63.7

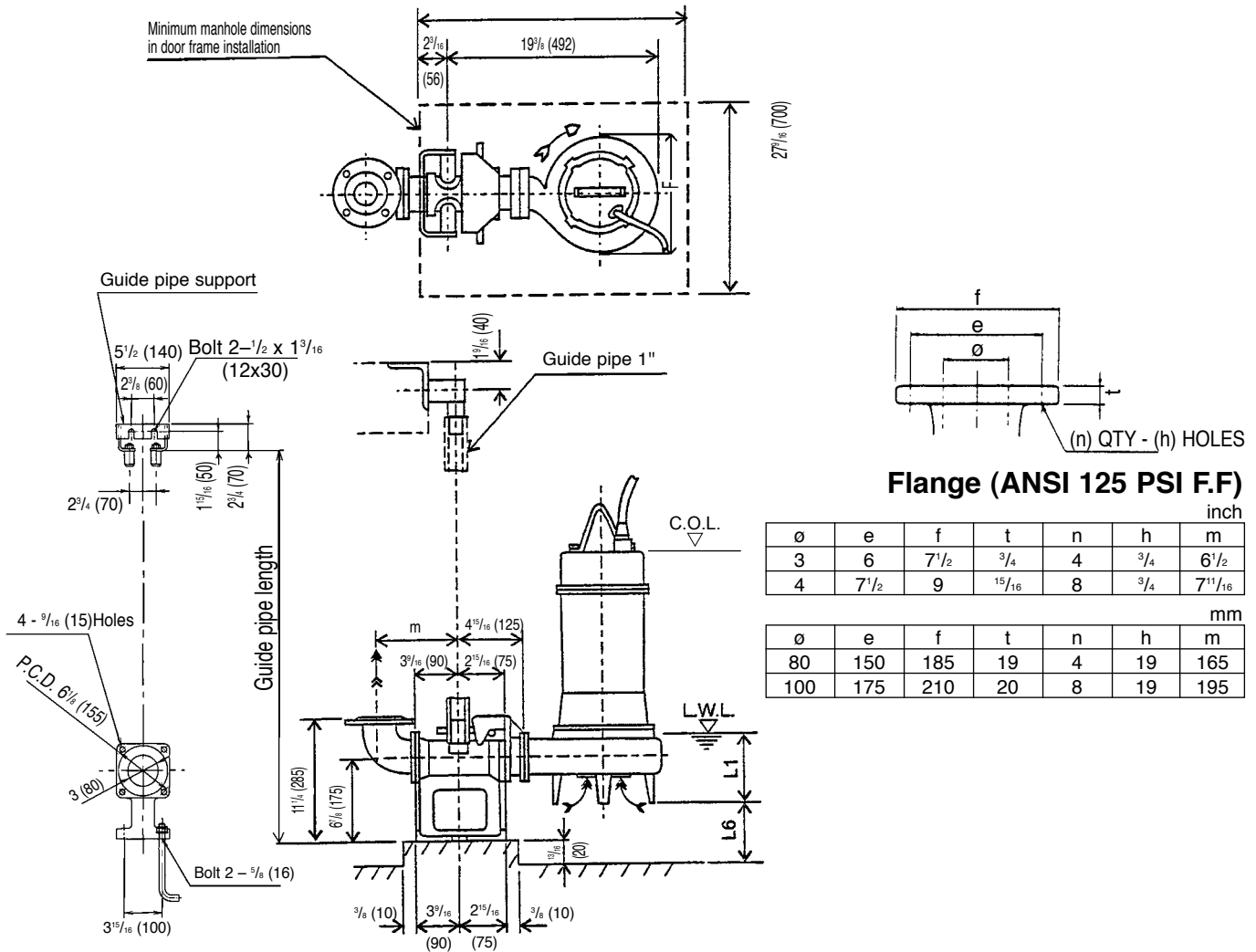

**Dimensions: inch**

PHASE	SIZE ø	MODEL	OUTPUT		Q.D.C. MODEL	PUMP & MOTOR			WEIGHT Lb	
			kW	HP		F	L1	L6	PUMP	Q.D.C.
THREE	3	80DMLEU62.2	2.2	3	LM80	12 5/8	11	1/4	176	37
		80DMLEU63.7	3.7	5	LM80	12 5/8	11	1/4	192	37
	4	100DMLEU63.7	3.7	5	LM80	12 5/8	11	1/4	196	37

**Dimensions: mm**

PHASE	SIZE ø	MODEL	OUTPUT		Q.D.C. MODEL	PUMP & MOTOR			WEIGHT kg	
			kW	HP		F	L1	L6	PUMP	Q.D.C.
THREE	80	80DMLEU62.2	2.2	3	LM80	320	279	7	80	17
		80DMLEU63.7	3.7	5	LM80	320	279	7	87	17
	100	100DMLEU63.7	3.7	5	LM80	320	279	7	89	17

**Dimensions**

Project: \_\_\_\_\_ Model: \_\_\_\_\_ Chk'd: \_\_\_\_\_ Date: \_\_\_\_\_

**Model DMLEU with Quick Discharge Connector**

80DMLEU  
100DMLEU

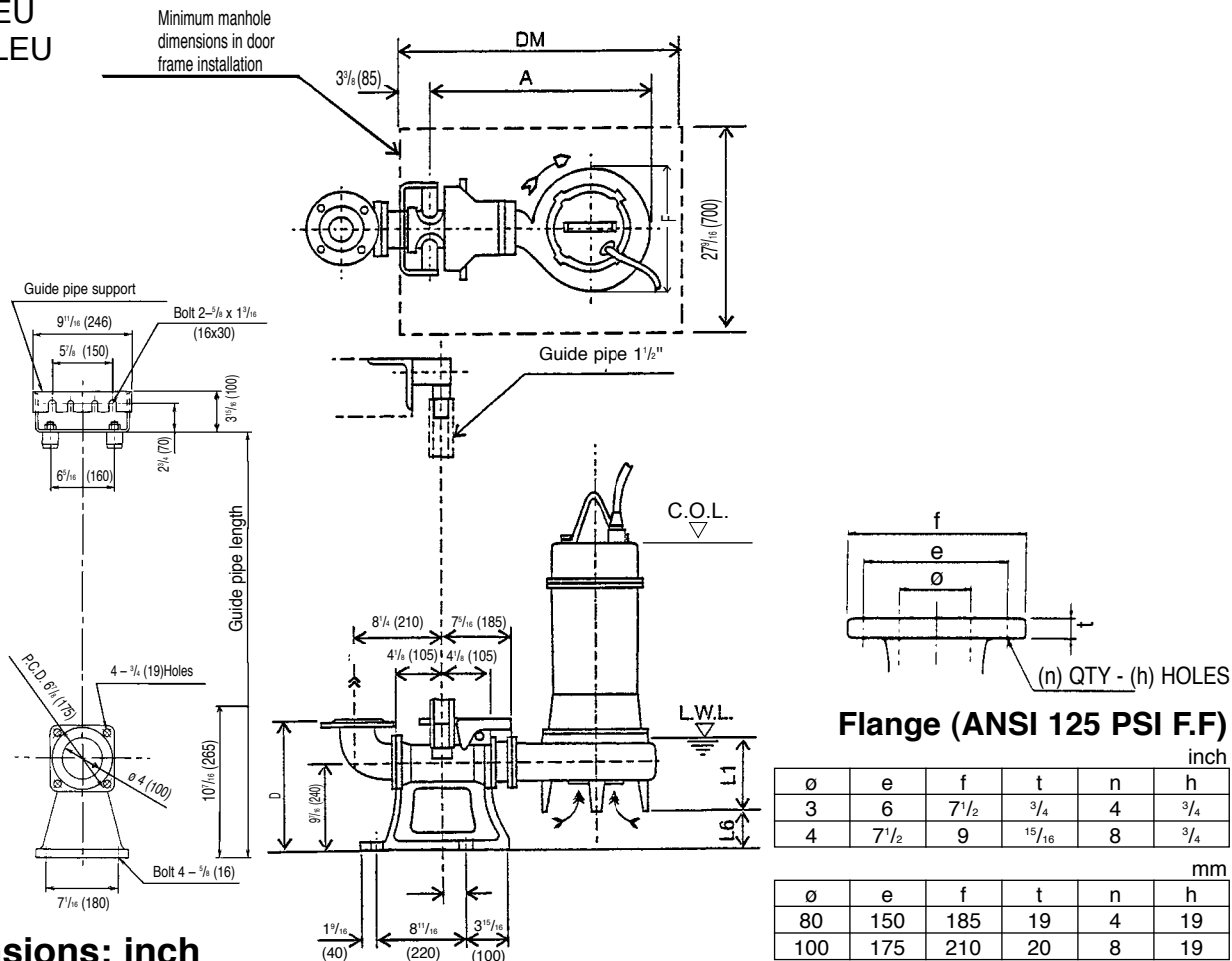

**Dimensions: inch**

PHASE	SIZE ø	MODEL	OUTPUT		Q.D.C. MODEL	PUMP & MOTOR						WEIGHT Lb	
			kW	HP		A	D	F	L1	L6	DM	PUMP	Q.D.C.
THREE	3	80DMLEU65.5	5.5	7.5	LL100	24 <sup>3</sup> / <sub>4</sub>	14 <sup>3</sup> / <sub>8</sub>	15	12 <sup>9</sup> / <sub>16</sub>	1 <sup>1</sup> / <sub>4</sub>	31 <sup>1</sup> / <sub>2</sub>	260	101
		80DMLEU67.5	7.5	10	LL100	24 <sup>3</sup> / <sub>4</sub>	14 <sup>3</sup> / <sub>8</sub>	15	12 <sup>9</sup> / <sub>16</sub>	1 <sup>1</sup> / <sub>4</sub>	31 <sup>1</sup> / <sub>2</sub>	271	101
		80DMLEU611	11	15	LL100	28 <sup>3</sup> / <sub>8</sub>	14 <sup>3</sup> / <sub>8</sub>	17 <sup>15</sup> / <sub>16</sub>	12 <sup>15</sup> / <sub>16</sub>	9 <sup>9</sup> / <sub>16</sub>	39 <sup>3</sup> / <sub>8</sub>	346	101
		80DMLEU615	15	20	LL100	28 <sup>3</sup> / <sub>8</sub>	14 <sup>3</sup> / <sub>8</sub>	17 <sup>15</sup> / <sub>16</sub>	12 <sup>15</sup> / <sub>16</sub>	9 <sup>9</sup> / <sub>16</sub>	39 <sup>3</sup> / <sub>8</sub>	359	101
	4	80DMLEU622	22	30	LL100	30 <sup>1</sup> / <sub>8</sub>	14 <sup>3</sup> / <sub>8</sub>	19 <sup>9</sup> / <sub>16</sub>	13 <sup>1</sup> / <sub>16</sub>	1 <sup>1</sup> / <sub>2</sub>	39 <sup>3</sup> / <sub>8</sub>	492	101
		100DMLEU65.5	5.5	7.5	LL100	24 <sup>3</sup> / <sub>4</sub>	14 <sup>3</sup> / <sub>8</sub>	15	12 <sup>9</sup> / <sub>16</sub>	1 <sup>1</sup> / <sub>4</sub>	31 <sup>1</sup> / <sub>2</sub>	267	101
		100DMLEU67.5	7.5	10	LL100	24 <sup>3</sup> / <sub>4</sub>	14 <sup>3</sup> / <sub>8</sub>	15	12 <sup>9</sup> / <sub>16</sub>	1 <sup>1</sup> / <sub>4</sub>	31 <sup>1</sup> / <sub>2</sub>	276	101
		100DMLEU611	11	15	LL100	28 <sup>3</sup> / <sub>8</sub>	14 <sup>3</sup> / <sub>8</sub>	17 <sup>15</sup> / <sub>16</sub>	12 <sup>15</sup> / <sub>16</sub>	9 <sup>9</sup> / <sub>16</sub>	39 <sup>3</sup> / <sub>8</sub>	353	101
4	100DMLEU615	15	20	LL100	28 <sup>3</sup> / <sub>8</sub>	14 <sup>3</sup> / <sub>8</sub>	17 <sup>15</sup> / <sub>16</sub>	12 <sup>15</sup> / <sub>16</sub>	9 <sup>9</sup> / <sub>16</sub>	39 <sup>3</sup> / <sub>8</sub>	366	101	
	100DMLEU622	22	30	LL100	30 <sup>1</sup> / <sub>8</sub>	14 <sup>3</sup> / <sub>8</sub>	19 <sup>9</sup> / <sub>16</sub>	13 <sup>1</sup> / <sub>16</sub>	1 <sup>1</sup> / <sub>2</sub>	39 <sup>3</sup> / <sub>8</sub>	498	101	

**Dimensions: mm**

PHASE	SIZE ø	MODEL	OUTPUT		Q.D.C. MODEL	PUMP & MOTOR						WEIGHT kg	
			kW	HP		A	D	F	L1	L6	DM	PUMP	Q.D.C.
THREE	80	80DMLEU65.5	5.5	7.5	LL100	628	365	381	310	31	800	118	46
		80DMLEU67.5	7.5	10	LL100	628	365	381	310	31	800	123	46
		80DMLEU611	11	15	LL100	721	365	455	329	15	1000	157	46
		80DMLEU615	15	20	LL100	721	365	455	329	15	1000	163	46
	100	80DMLEU622	22	30	LL100	765	365	497	332	12	1000	223	46
		100DMLEU65.5	5.5	7.5	LL100	628	365	381	310	31	800	121	46
		100DMLEU67.5	7.5	10	LL100	628	365	381	310	31	800	125	46
		100DMLEU611	11	15	LL100	721	365	455	329	15	1000	160	46
4	100DMLEU615	15	20	LL100	721	365	455	329	15	1000	166	46	
	100DMLEU622	22	30	LL100	765	365	497	332	12	1000	226	46	

**Dimensions**

Project: \_\_\_\_\_ Model: \_\_\_\_\_ Chk'd: \_\_\_\_\_ Date: \_\_\_\_\_

**Model DMLEU with Quick Discharge Connector**  
150DMLEU

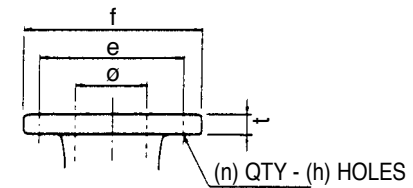
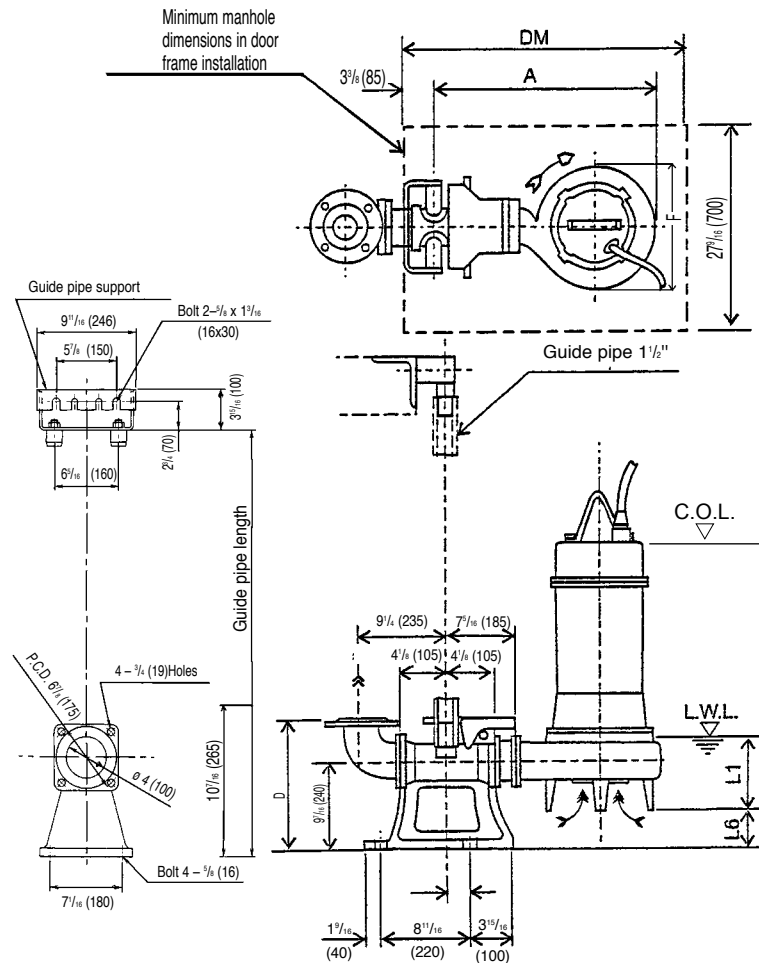

**Flange (ANSI 125 PSI F.F)**

inch					
ø	e	f	t	n	h
6	9 1/2	11	1	8	3/4

mm					
ø	e	f	t	n	h
150	240	280	212	8	19

**Dimensions: inch**

PHASE	SIZE ø	MODEL	OUTPUT		Q.D.C. MODEL	PUMP & MOTOR					WEIGHT Lb		
			kW	HP		A	D	F	L1	L6	DM	PUMP	Q.D.C.
THREE	6	150DMLEU65.5	5.5	7.5	LL100	24 3/4	15 3/4	15	12 3/16	1 1/4	31 1/2	280	101
		150DMLEU67.5	7.5	10	LL100	24 3/4	15 3/4	15	12 3/16	1 1/4	31 1/2	291	101
		150DMLEU611	11	115	LL100	28 3/8	15 3/4	17 15/16	12 15/16	9/16	39 3/8	366	101
		150DMLEU615	15	20	LL100	28 3/8	15 3/4	17 15/16	12 15/16	9/16	39 3/8	379	101
		150DMLEU622	22	30	LL100	30 1/8	15 3/4	19 9/16	13 1/16	1/2	39 3/8	511	101

**Dimensions: mm**

PHASE	SIZE ø	MODEL	OUTPUT		Q.D.C. MODEL	PUMP & MOTOR					WEIGHT kg		
			kW	HP		A	D	F	L1	L6	DM	PUMP	Q.D.C.
THREE	150	150DMLEU65.5	5.5	7.5	LL100	628	400	381	310	31	800	127	46
		150DMLEU67.5	7.5	10	LL100	628	400	381	310	31	800	132	46
		150DMLEU611	11	115	LL100	721	400	455	329	15	1000	166	46
		150DMLEU615	15	20	LL100	721	400	455	329	15	1000	172	46
		150DMLEU622	22	30	LL100	765	400	497	332	12	1000	232	46

**Sectional View**

Project: \_\_\_\_\_ Model: \_\_\_\_\_ Chk'd: \_\_\_\_\_ Date: \_\_\_\_\_

**80DMLE62.2**

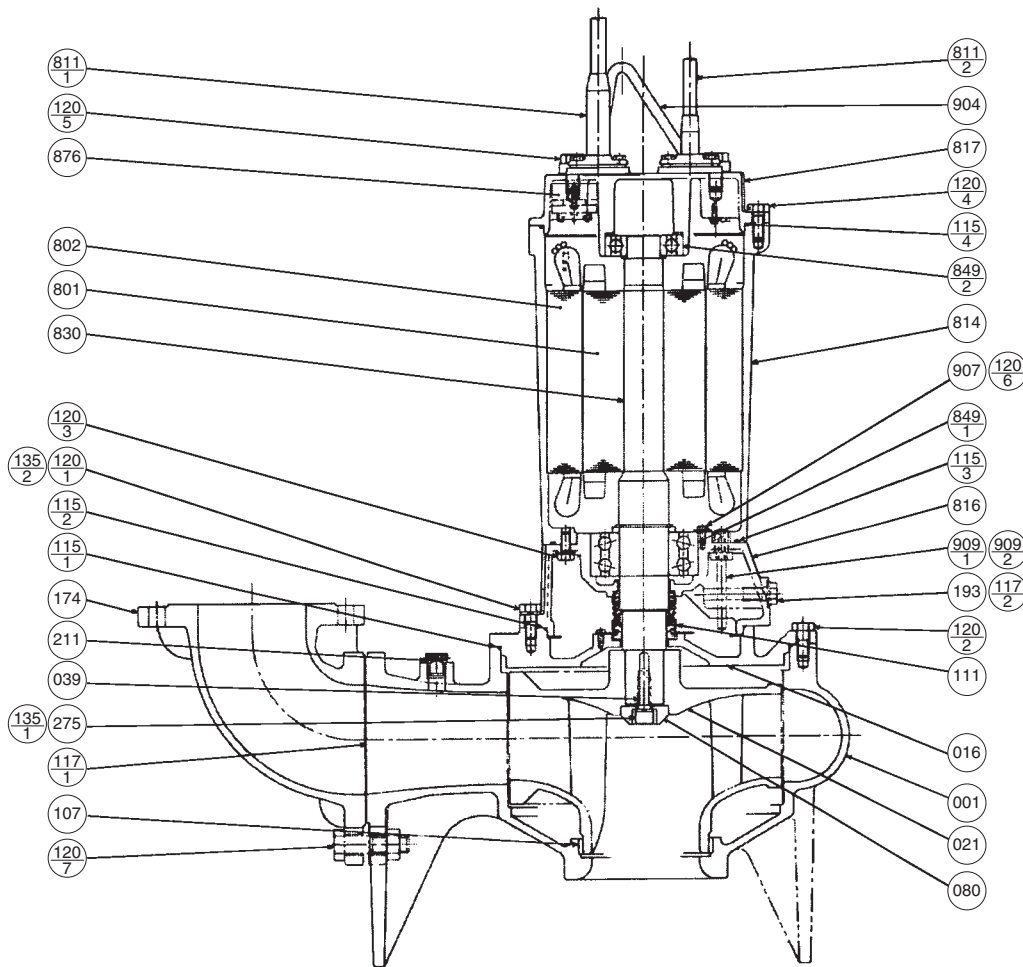

PART NO.	PART NAME	MATERIAL	NO. FOR 1 UNIT
909-2	ELECTRODE HOLDER	PVC	1
909-1	ELECTRODE	SUS304	1
907	BEARING COVER	SPCC	1
904	LIFTING HANGER	SS400	1
876	AUTO CUT	—	1
849-2	BALL BEARING	—	1
849-1	BALL BEARING	—	1
830	SHAFT	SUS403	1
817	OPPOSITE SIDE BRACKET	FC200	1
816	POWER SIDE BRACKET	FC200	1
814	MOTOR FRAME	FC200	1
811-2	SUBMERSIBLE CABLE	—	1
811-1	SUBMERSIBLE CABLE	—	1
802	STATOR	—	1
801	ROTOR	—	1
275	IMPELLER BOLT	SUS304	1
211	AIR VENT VALVE	C3604	1
193	OIL PLUG	SUS304	1
174	DISCHARGE PIPE	FC200	1
135-2	WASHER	SUS304	4
135-1	WASHER	SUS304	1

PART NO.	PART NAME	MATERIAL	NO. FOR 1 UNIT
120-7	BOLT	SUS304	4
120-6	BOLT	SUS304	3
120-5	BOLT	SUS304	2
120-4	BOLT	SUS304	4
120-3	BOLT	SUS304	4
120-2	BOLT	SUS304	8
120-1	BOLT	SUS304	4
117-2	SEAL WASHER	NBR/304	1
117-1	FLANGE GASKET	—	1
115-4	O-RING	NBR	1
115-3	O-RING	NBR	1
115-2	O-RING	NBR	1
115-1	O-RING	NBR	1
111	MECHANICAL SEAL	—	1
107	WEARING RING	CAC406	1
080	BUSHING	SS400	1
039	KEY	SUS420J2	1
021	IMPELLER	FC200	1
016	MECHANICAL SEAL COVER	FC200	1
001	CASING	FC200	1

**Sectional View**

Project: \_\_\_\_\_ Model: \_\_\_\_\_ Chk'd: \_\_\_\_\_ Date: \_\_\_\_\_

**5 to 10 HP  
80DMLE  
100DMLE  
150DMLE**

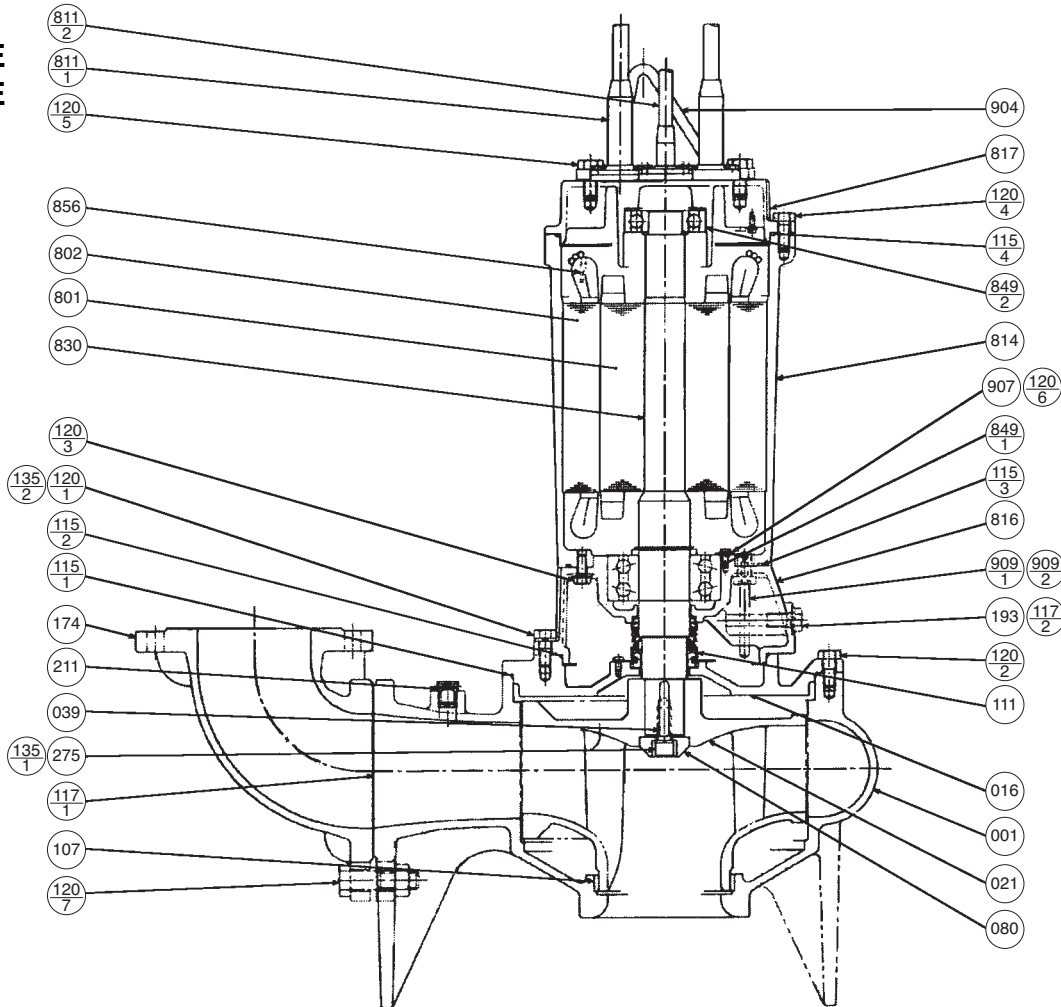

PART NO.	PART NAME	MATERIAL	NO. FOR 1 UNIT
909-2	ELECTRODE HOLDER	PVC	1
909-1	ELECTRODE	SUS304	1
907	BEARING COVER	SPCC	3
904	LIFTING HANGER	SS400	1
856	THERMAL PROTECTOR	—	2
849-2	BALL BEARING	—	1
849-1	BALL BEARING	—	1
830	SHAFT	SUS403	1
817	OPPOSITE SIDE BRACKET	FC200	1
816	POWER SIDE BRACKET	FC200	1
814	MOTOR FRAME	FC200	1
811-2	SUBMERSIBLE CABLE	—	1
811-1	SUBMERSIBLE CABLE	—	2
802	STATOR	—	1
801	ROTOR	—	1
275	IMPELLER BOLT	SUS304	1
211	AIR VENT VALVE	C3604	1
193	OIL PLUG	SUS304	1
174	DISCHARGE PIPE	FC200	1
135-2	WASHER	SUS304	4
135-1	WASHER	SUS304	1

PART NO.	PART NAME	MATERIAL	NO. FOR 1 UNIT
120-7	BOLT	SUS304	4
120-6	BOLT	SUS304	3
120-5	BOLT	SUS304	2
120-4	BOLT	SUS304	4
120-3	BOLT	SUS304	4
120-2	BOLT	SUS304	8
120-1	BOLT	SUS304	4
117-2	SEAL WASHER	NBR/304	1
117-1	FLANGE GASKET	—	1
115-4	O-RING	NBR	1
115-3	O-RING	NBR	1
115-2	O-RING	NBR	1
115-1	O-RING	NBR	1
111	MECHANICAL SEAL	—	1
107	WEARING RING	CAC406	1
080	BUSHING	SS400	1
039	KEY	SUS420J2	1
021	IMPELLER	FC200	1
016	MECHANICAL SEAL COVER	FC200	1
001	CASING	FC200	1



**Sectional View**

Project: \_\_\_\_\_ Model: \_\_\_\_\_ Chk'd: \_\_\_\_\_ Date: \_\_\_\_\_

**15 to 30HP  
80DMLE  
100DMLE  
150DMLE**

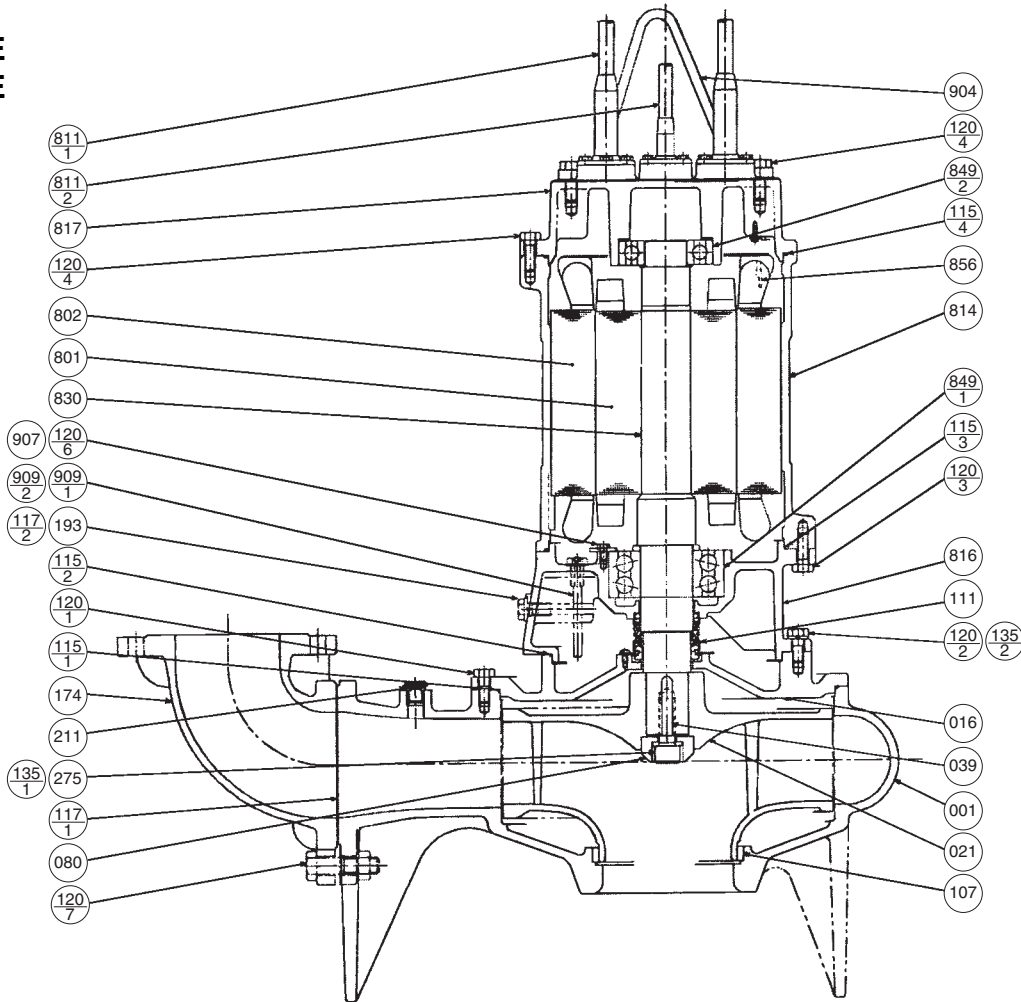

PART NO.	PART NAME	MATERIAL	NO. FOR 1 UNIT
909-2	ELECTRODE HOLDER	PVC	1
909-1	ELECTRODE	SUS304	1
907	BEARING COVER	SPCC	3
904	LIFTING HANGER	SS400	1
856	THERMAL PROTECTOR	—	2
849-2	BALL BEARING	—	1
849-1	BALL BEARING	—	1
830	SHAFT	SUS403	1
817	OPPOSITE SIDE BRACKET	FC200	1
816	POWER SIDE BRACKET	FC200	1
814	MOTOR FRAME	FC200	1
811-2	SUBMERSIBLE CABLE	—	1
811-1	SUBMERSIBLE CABLE	—	2
802	STATOR	—	1
801	ROTOR	—	1
275	IMPELLER BOLT	SUS304	1
211	AIR VENT VALVE	C3604	1
193	OIL PLUG	SUS304	1
174	DISCHARGE PIPE	FC200	1
135-2	WASHER	SUS304	4
135-1	WASHER	SUS304	1

PART NO.	PART NAME	MATERIAL	NO. FOR 1 UNIT
120-7	BOLT	SUS304	4
120-6	BOLT	SUS304	3
120-5	BOLT	SUS304	2
120-4	BOLT	SUS304	6
120-3	BOLT	SUS304	4
120-2	BOLT	SUS304	4
120-1	BOLT	SUS304	8
117-2	SEAL WASHER	NBR/304	1
117-1	FLANGE GASKET	—	1
115-4	O-RING	NBR	1
115-3	O-RING	NBR	1
115-2	O-RING	NBR	1
115-1	O-RING	NBR	1
111	MECHANICAL SEAL	—	1
107	WEARING RING	CAC406	1
080	BUSHING	SS400	1
039	KEY	SUS420J2	1
021	IMPELLER	FC200	1
016	MECHANICAL SEAL COVER	FC200	1
001	CASING	FC200	1

**Motor Data**

Project: \_\_\_\_\_ Model: \_\_\_\_\_ Chk'd: \_\_\_\_\_ Date: \_\_\_\_\_

**Models DMLEU**  
**Three Phase**  
**3 to 30HP**  
**60HZ**  
**208/230V**

Nameplate Rating	Output	HP	3	5	7½	10	15	20	30
		kW	2.2	3.7	5.5	7.5	11	15	22
	Phase		3	3	3	3	3	3	3
	Poles		4	4	4	4	4	4	4
	Volts	V	208/230	208/230	208/230	208/230	208/230	208/230	208/230
	Amperes	A	10.3/9.8	16.2/15.4	23.7/23.0	30.4/29.8	42.8/41.2	57.6/54.6	78.6/73.2
	Speed	min <sup>-1</sup>	1700/1720	1700/1720	1725/1740	1735/1750	1745/1750	1750/1760	1765/1770
	Insulation Class		F	F	F	F	F	F	F
Capacitor	Start	µF	—	—	—	—	—	—	—
	Run	µF	—	—	—	—	—	—	—
No Load Test	Amperes	A	3.55/4.44	5.43/6.84	9.09/11.64	11.25/14.53	13.46/17.64	17.13/22.20	21.28/26.97
	Watts	W	650/750	750/1100	1200/1400	1200/1450	1175/1600	1780/2150	1800/2100
Resistance at 20°C		Ω	1.89	0.975	0.502	0.354	0.257	0.164	0.083
100% Load	Amperes	A	10.3/9.8	16.2/15.4	23.7/23.0	30.4/29.8	42.8/41.2	57.6/54.6	78.6/73.2
	Efficiency	%	66.68/64.68	69.96/69.03	72.89/71.13	77.48/74.90	80.48/78.26	80.23/79.27	86.45/86.63
	Power Factor	%	89.32/86.28	90.24/87.28	88.29/84.13	88.15/84.12	88.41/85.46	89.88/86.80	89.84/87.49
	Speed	min <sup>-1</sup>	1702/1721	1707/1728	1732/1743	1743/1755	1748/1757	1754/1763	1767/1773
Locked Rotor Torque		%	184/219	205/245	232/278	237/287	153/184	168/201	144/173
Starting Current		A	48.4/53.0	88.7/97.8	150.7/166.6	209.9/229.6	240.3/264.6	375.0/413.8	528.6/584.4
Number Starts Per Hour			20	20	20	20	20	20	20
Design Standard			JEC37						
Voltage Tolerance		%	-10 to 6%	±10%	±10%	±10%	±10%	±10%	±10%
Frequency Tolerance		%	±5%	±5%	±5%	±5%	±5%	±5%	±5%

**Motor Data**

Project: \_\_\_\_\_ Model: \_\_\_\_\_ Chk'd: \_\_\_\_\_ Date: \_\_\_\_\_

**Models DMLEU**  
**Three Phase**  
**3 to 30HP**  
**60HZ**  
**460V**

Name-Plate Rating	Output	HP	3	5	7½	10	15	20	30
		kW	2.2	3.7	5.5	7.5	11	15	22
	Phase		3	3	3	3	3	3	3
	Poles		4	4	4	4	4	4	4
	Volts V		460	460	460	460	460	460	460
	Amperes A		4.9	7.7	11.5	14.9	20.6	27.3	36.6
	Speed min <sup>-1</sup>		1720	1720	1740	1750	1750	1760	1770
	Insulation Class		F	F	F	F	F	F	F
Capacitor µF		Start	—	—	—	—	—	—	—
		Run	—	—	—	—	—	—	—
No Load Test		Amperes A	2.22	3.42	5.82	7.27	8.82	11.1	13.48
		Watts	750	1100	1400	1450	1600	2150	2100
Resistance at 20°C		OHMS Ω	6.953	3.592	1.842	1.248	0.863	0.549	0.289
100% Load	Current Amp.	4.9	7.7	11.5	14.9	20.6	27.3	36.6	
	Efficiency %	64.68	69.03	71.13	74.9	78.26	79.27	86.63	
	Power Factor %	86.28	87.28	84.13	84.12	85.46	86.8	87.49	
	Speed min <sup>-1</sup>	1721	1728	1743	1755	1757	1763	1773	
Locked Rotor Torque		%	222	248	278	287	184	201	173
Starting Current		A	26.5	48.9	83.3	114.8	132.3	206.9	292.2
Number Starts Per Hour			20	20	20	20	20	20	20
Design Standard			JEC37						
Voltage Tolerance		%	-10 to +6%	±10%	±10%	±10%	±10%	±10%	±10%
Frequency Tolerance		%	±5%	±5%	±5%	±5%	±5%	±5%	±5%



**Motor Specification**

Project: \_\_\_\_\_ Model: \_\_\_\_\_ Chk'd: \_\_\_\_\_ Date: \_\_\_\_\_

**Power Cable Specification**

OUTPUT		PHASE	VOLTAGE V	GAUGE mm <sup>2</sup>	NUMBER OF COND.	DETAILS OF CONDUCTOR		INSULATOR THICKNESS mm	SHEATH THICKNESS mm	CABLE O.D. mm	CONDUCTOR RESISTANCE at 20 °C/km
HP	KW					QTY/DIA. OF WIRE PCS/mm	DIAMETER mm				
3	2.2	THREE	208/230/460	2	4	37/0.26	1.8	0.8	1.8	11.8	9.79
5	3.7	THREE	208/230/460	2	4	37/0.26	1.8	0.8	1.8	11.8	9.79
					3	37/0.26	1.8	0.8	1.8	10.9	9.79
7½	5.5	THREE	208/230/460	3.5	4	45/0.32	2.5	0.8	2	13.9	5.24
					3	45/0.32	2.5	0.8	1.9	12.6	5.24
10	7.5	THREE	208/230/460	3.5	4	45/0.32	2.5	0.8	2	13.9	5.24
					3	45/0.32	2.5	0.8	1.9	12.6	5.24
15	11	THREE	208/230/460	3.5	4	45/0.32	2.5	0.8	2	13.9	5.24
					3	45/0.32	2.5	0.8	1.9	12.6	5.24
20	15	THREE	208/230/460	5.5	4	70/0.32	3.1	1	2.1	16.5	3.37
					3	70/0.32	3.1	1	2	15	3.37
30	22	THREE	208/230/460	14	4	88/0.45	4.9	1	2.4	22	1.43
					3	88/0.45	4.9	1	2.3	20	1.43

**Sensor Cable Specifications**

OUTPUT		PHASE	VOLTAGE V	GAUGE AWG	NUMBER OF COND.	DETAILS OF CONDUCTOR		INSULATOR THICKNESS mm	SHEATH THICKNESS mm	CABLE O.D. mm	CONDUCTOR RESISTANCE at 20 °C/km
HP	KW					QTY/DIA. OF WIRE PCS/mm	DIAMETER mm				
3	2.2	THREE	208/230/460	#16	2	50/0.18	1.25	0.8	1.7	9.6	15.1
5-30	3.7-22				4			11	1.8	11.1	



**Motor Wiring Diagram**

Project:

Model:

Chk'd:

Date:

Output 3HP  
208/230V

LINE CABLE

E- GREEN

U- RED

V- WHITE

W- BLACK

CONTROL CABLE

WHITE, BLACK

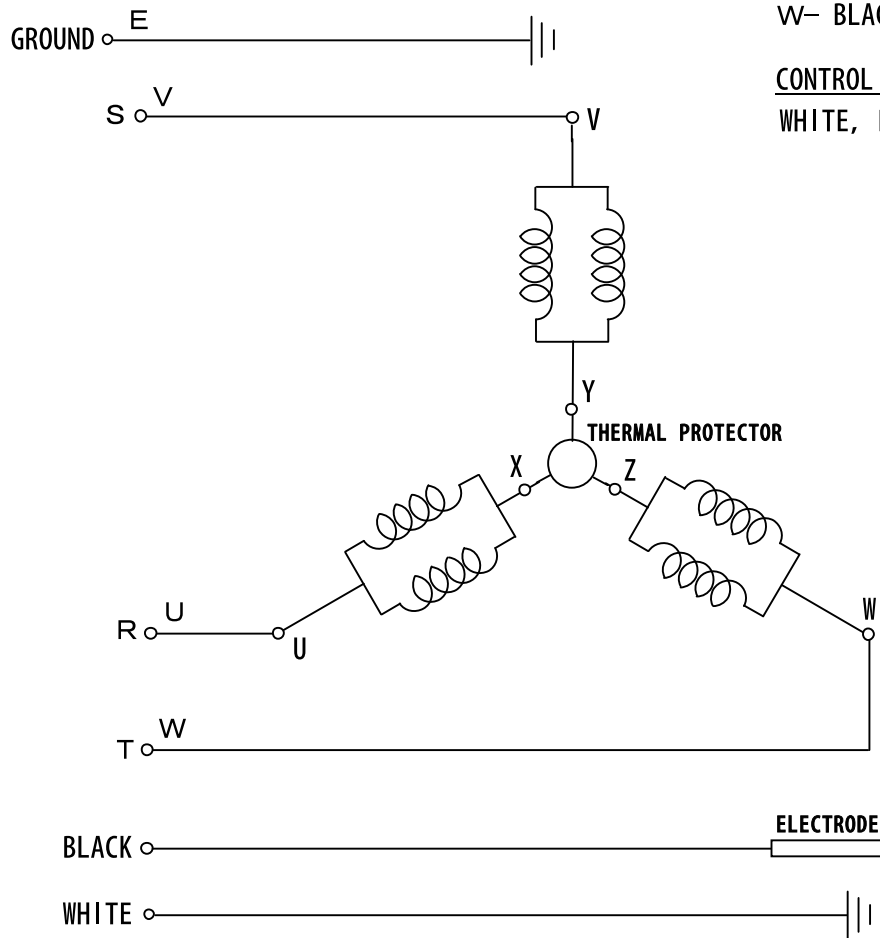

**Motor Wiring Diagram**

Project: \_\_\_\_\_ Model: \_\_\_\_\_ Chk'd: \_\_\_\_\_ Date: \_\_\_\_\_

Output 3HP  
460V

LINE CABLE

E- GREEN

U- RED

V- WHITE

W- BLACK

CONTROL CABLE

WHITE, BLACK

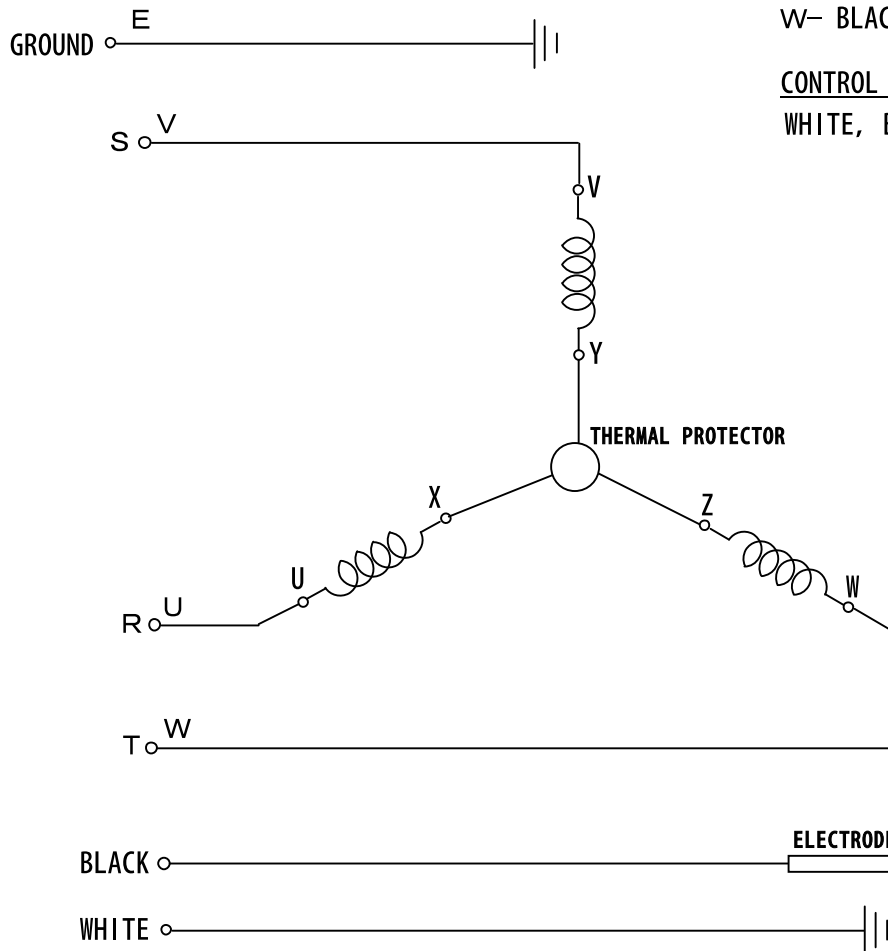

**Motor Wiring Diagram**

Project: \_\_\_\_\_ Model: \_\_\_\_\_ Chk'd: \_\_\_\_\_ Date: \_\_\_\_\_

Output 5, 7.5, 15, 20, 30HP  
208/230V

LINE CABLE

E- GREEN

U- RED

Z- RED

V- WHITE

X- WHITE

W- BLACK

Y- BLACK

CONTROL CABLE

P 1- RED

P 2- WHITE

P 3- BLACK

P 4- GREEN

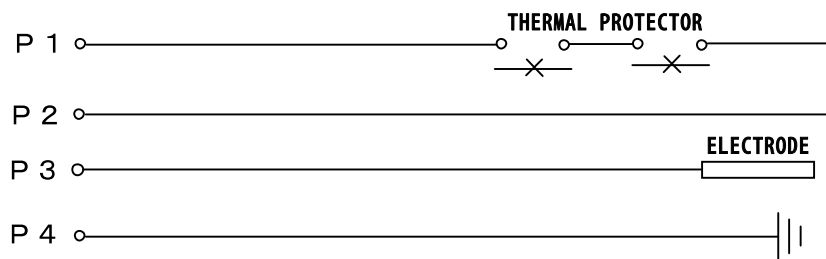
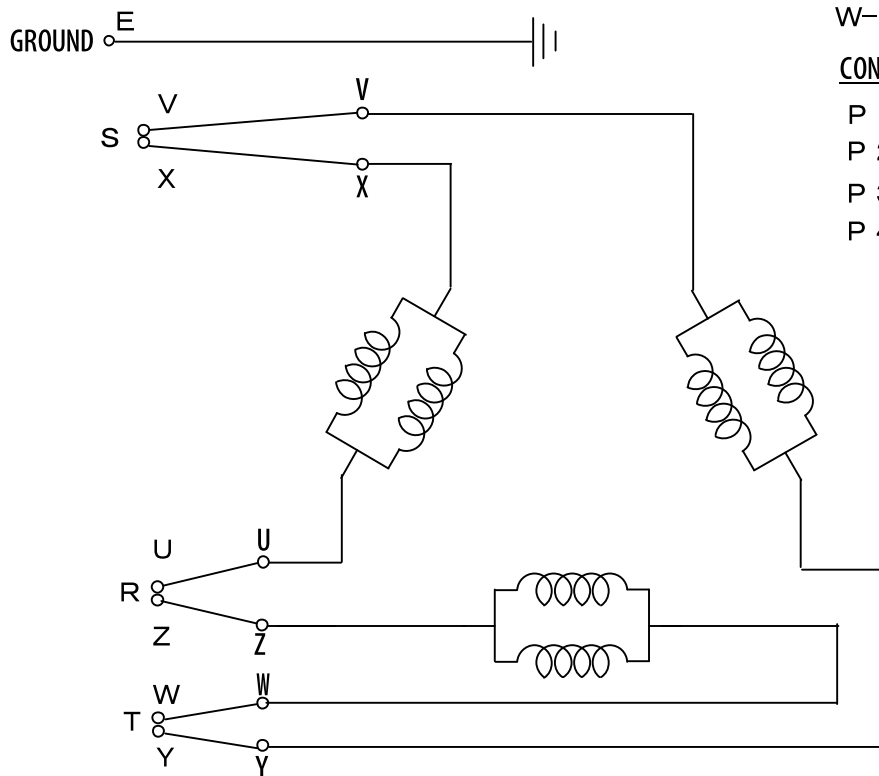

**Motor Wiring Diagram**

Project:

Model:

Chk'd:

Date:

Output 5, 7.5, 15, 20, 30HP  
460V

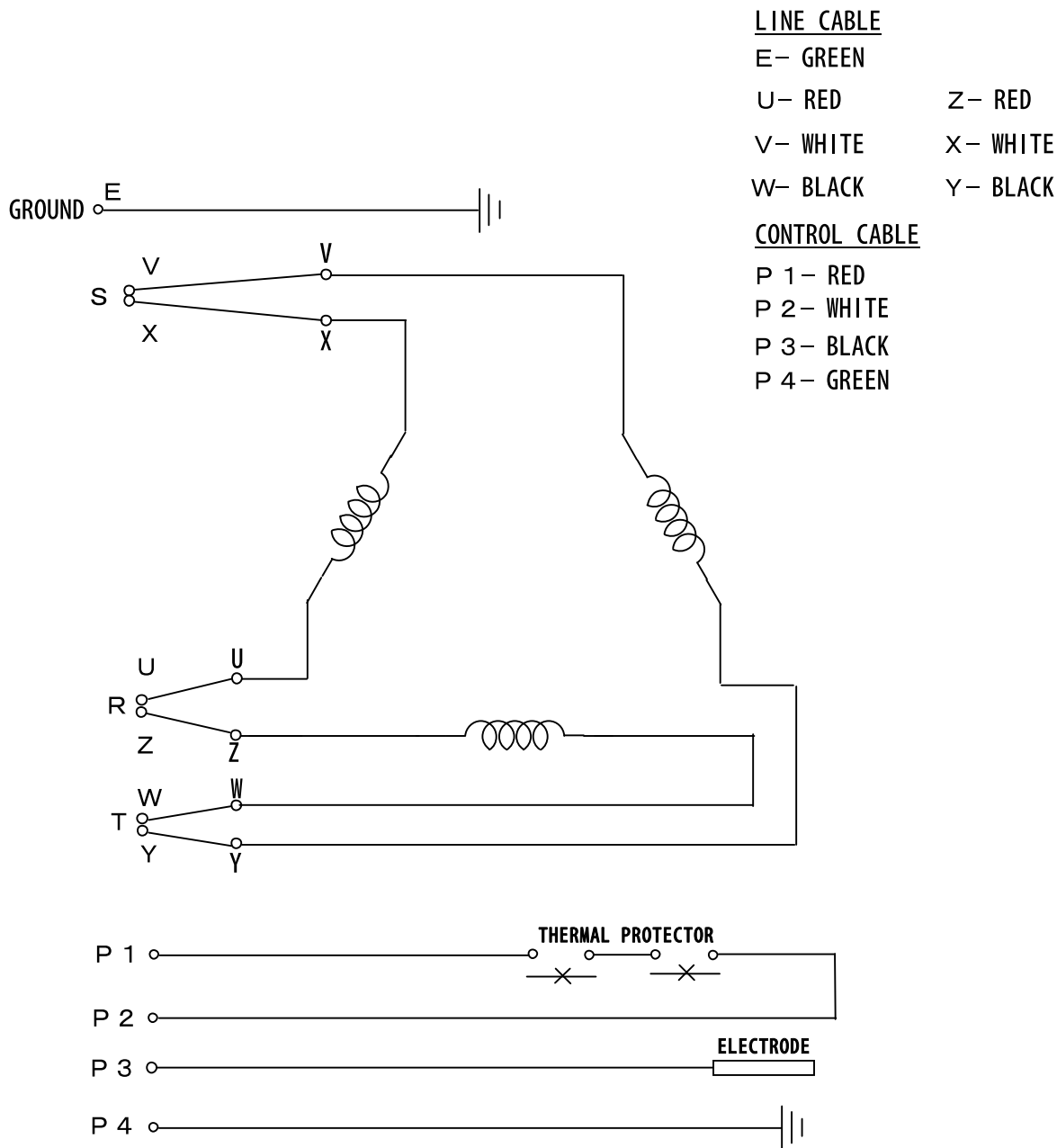



**Motor Wiring Diagram**

Project:

Model:

Chk'd:

Date:

Output 10HP  
208/230V

LINE CABLE

- E- GREEN
- U- RED            Z- RED
- V- WHITE        X- WHITE
- W- BLACK        Y- BLACK

CONTROL CABLE

- P 1- RED
- P 2- WHITE
- P 3- BLACK
- P 4- GREEN

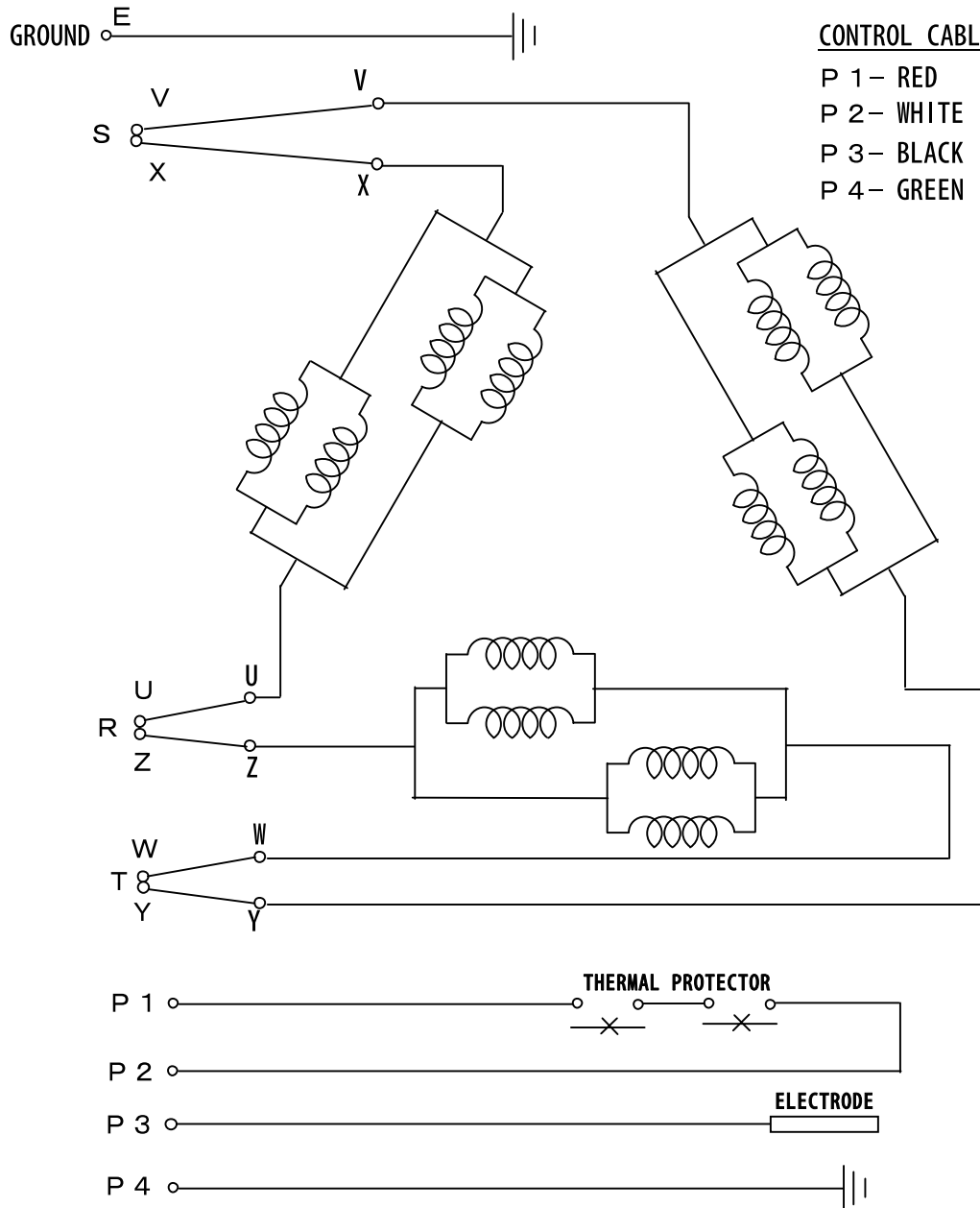

**Motor Wiring Diagram**

Project:

Model:

Chk'd:

Date:

Output 10HP  
460V

LINE CABLE

- E- GREEN
- U- RED            Z- RED
- V- WHITE        X- WHITE
- W- BLACK        Y- BLACK

CONTROL CABLE

- P 1- RED
- P 2- WHITE
- P 3- BLACK
- P 4- GREEN

