

Sectional View

Project: _____ Model: _____ Chk'd: _____ Date: _____

Model DSC3 with Quick Discharge Connector

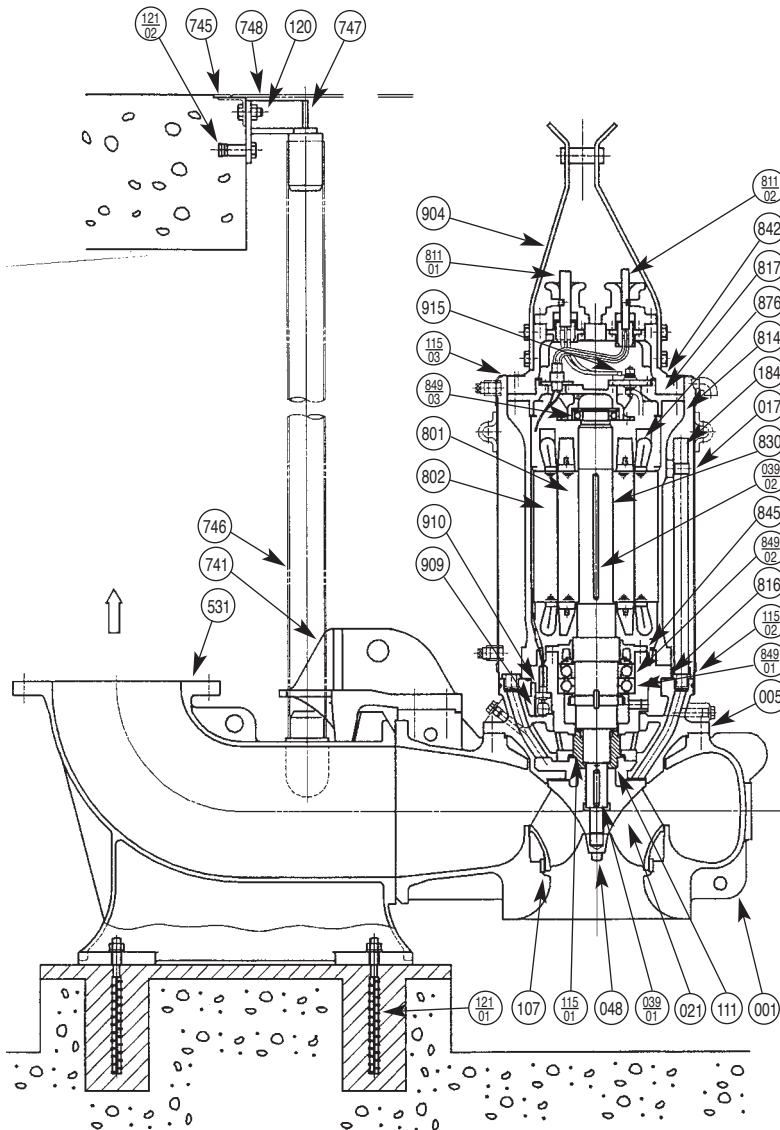

Part No.	Part Name	Material	ASTM, AISI Code	No. for 1 Unit
915	Terminal Board	-	-	1
910	Leakage Detector Support	Cast Iron	ASTM A48 CL.30	1
909	Leakage Detector	-	-	1
904	Lifting Hanger	Steel	ASTM A 283 GR.D	1
876	Thermal Protector	-	-	1
849-03	Ball Bearing	-	-	1
849-02	Ball Bearing	-	-	1
849-01	Ball Bearing	-	-	1
845	Bearing Cover	Cast Iron	ASTM A48 CL.30	1
842	Motor Cover	Cast Iron	ASTM A48 CL.35	1
830	Shaft	Stainless	AISI 403	1
817	Opposite Side Bracket	Cast Iron	ASTM A48 CL.35	1
816	Power Side Bracket	Cast Iron	ASTM A48 CL.35	1
814	Motor Frame	Cast Iron	ASTM A48 CL.35	1
811-02	Control Cord	-	-	1
811-01	Line Cord	-	-	1
802	Stator	-	-	1
801	Rotor	-	-	1
748	Floor Plate	Steel	ASTM A283 GR.D	1
747	Guide Pipe Support	Steel	ASTM A283 GR.D	1
746	Guide Pipe	Stainless	AISI 304	2
745	Floor Frame	Steel	ASTM A283 GR.D	1
741	Sliding Guide	Ductile Iron	ASTM A536 60-40-18	1
531	Quick Discharge Connector	Cast Iron	ASTM A48 CL.35	1
184	Cooling Water Pipe	SGP	ASTM A120	4
121-02	Hole-In Anchor	Stainless	AISI 304	2
121-01	Anchor Bolt	Stainless	AISI 304	4
120	Holder Bolt	Stainless	AISI 304	2
115-03	O-Ring	NBR	-	1
115-02	O-Ring	NBR	-	1
115-01	O-Ring	NBR	-	1 Set
111	Mechanical Seal	-	-	1
107	Casing Ring	Stainless	AISI 403	1
048	Impeller Nut	Stainless	AISI 403	1
039-02	Key	S50C	AISI 1050	1
039-01	Key	Stainless	AISI 420	1
021	Impeller *	Cast Iron	ASTM A48 CL.35	1
017	Cooling Jacket	Steel	ASTM A283 GR.D	1
005	Intermediate Casing	Cast Iron	ASTM A48 CL.35	1
001	Pump Casing	Cast Iron	ASTM A48 CL.35	1

* Ductile Iron for Models: E1262-1780
 F1102-1780
 F1302-1780
 G1012-1780
 G1102-1780
 G1232-1780
 F1593-1180

Sectional View

Project:

Model:

Chk'd:

Date:

Model DSCA3 Drypit Application

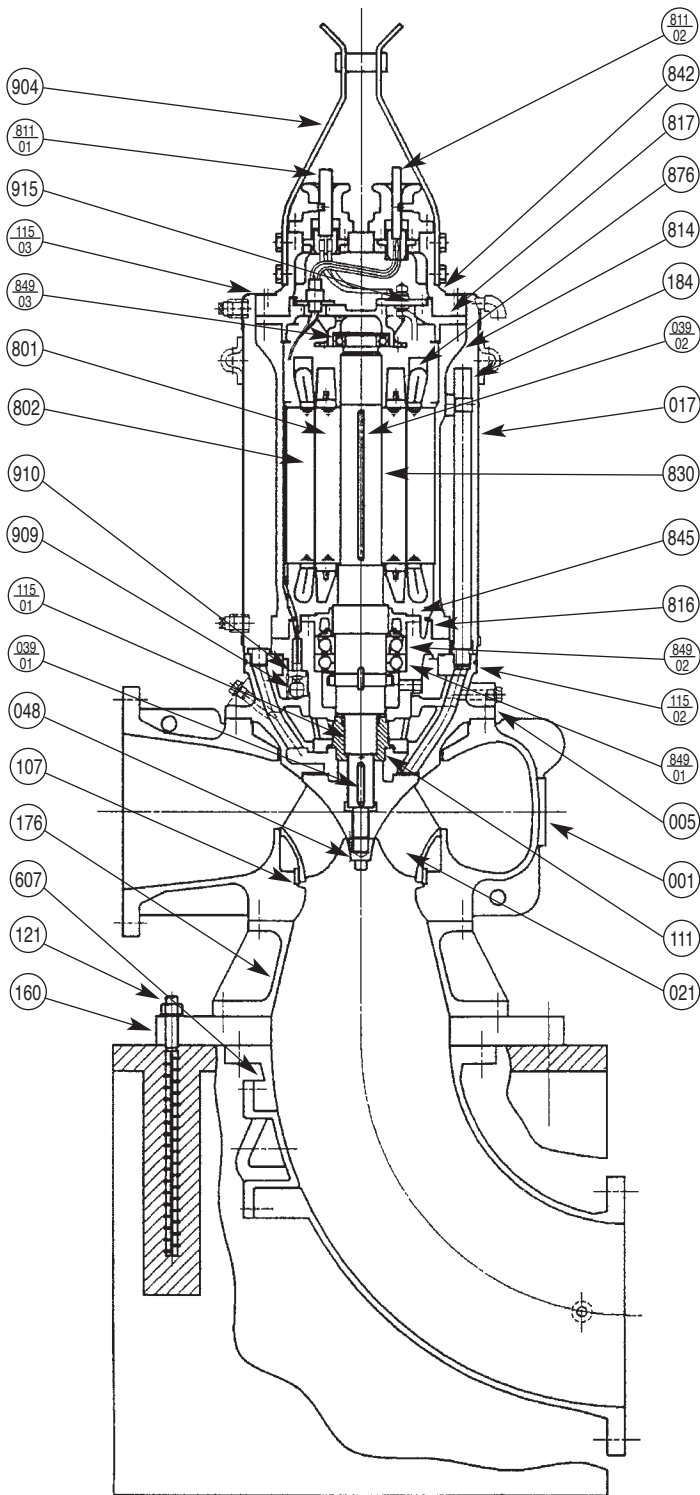

Part No.	Part Name	Material	ASTM, AISI Code	No. for 1 Unit
915	Terminal Board	-	-	1
910	Leakage Detector Support	Cast Iron	ASTM A48 CL.30	1
909	Leakage Detector	-	-	1
904	Lifting Hanger	Steel	ASTM A 283 GR.D	1
876	Thermal Protector	-	-	1
849-03	Ball Bearing	-	-	1
849-02	Ball Bearing	-	-	1
849-01	Ball Bearing	-	-	1
845	Bearing Cover	Cast Iron	ASTM A48 CL.30	1
842	Motor Cover	Cast Iron	ASTM A48 CL.35	1
830	Shaft	Stainless	AISI 403	1
817	Opposite Side Bracket	Cast Iron	ASTM A48 CL.35	1
816	Power Side Bracket	Cast Iron	ASTM A48 CL.35	1
814	Motor Frame	Cast Iron	ASTM A48 CL.35	1
811-02	Control Cord	-	-	1
811-01	Line Cord	-	-	1
802	Stator	-	-	1
801	Rotor	-	-	1
607	Suction Elbow	Cast Iron	ASTM A48 CL.35	1
184	Cooling Water Pipe	SGP	ASTM A120	4
176	Conical Pipe	Cast Iron	ASTM A48 CL.35	1
160	Base	Steel	ASTM A283 GR.D	1
121	Anchor Bolt	Stainless	AISI 304	4
115-03	O-Ring	NBR	-	1
115-02	O-Ring	NBR	-	1
115-01	O-Ring	NBR	-	1 Set
111	Mechanical Seal	-	-	1
107	Casing Ring	Stainless	AISI 403	1
048	Impeller Nut	Stainless	AISI 403	1
039-02	Key	S50C	AISI 1050	1
039-01	Key	Stainless	AISI 420	1
021	Impeller*	Cast Iron	ASTM A48 CL.35	1
017	Cooling Jacket	Steel	ASTM A283 GR.D	1
005	Intermediate Casing	Cast Iron	ASTM A48 CL.35	1
001	Pump Casing	Cast Iron	ASTM A48 CL.35	1

* Ductile Iron for Models: E1262-1780
 F1102-1780
 F1302-1780
 G1012-1780
 G1102-1780
 G1232-1780
 F1593-1180