

Model DGUII/DGFU



Technical Data



EBARA

EBARA Pumps Americas Corporation

Contents

Models

32DGUII61.5S
32DGFU61.5
50DGFU62.2S
50DGFU62.2
50DGFU63.7S
50DGFU63.7

Section	Page
Model Designation	2-137
Specifications	2-138
Selection Chart	2-139
Performance Curves	2-148
Dimensions	2-152
Sectional View	2-157



Model Designation

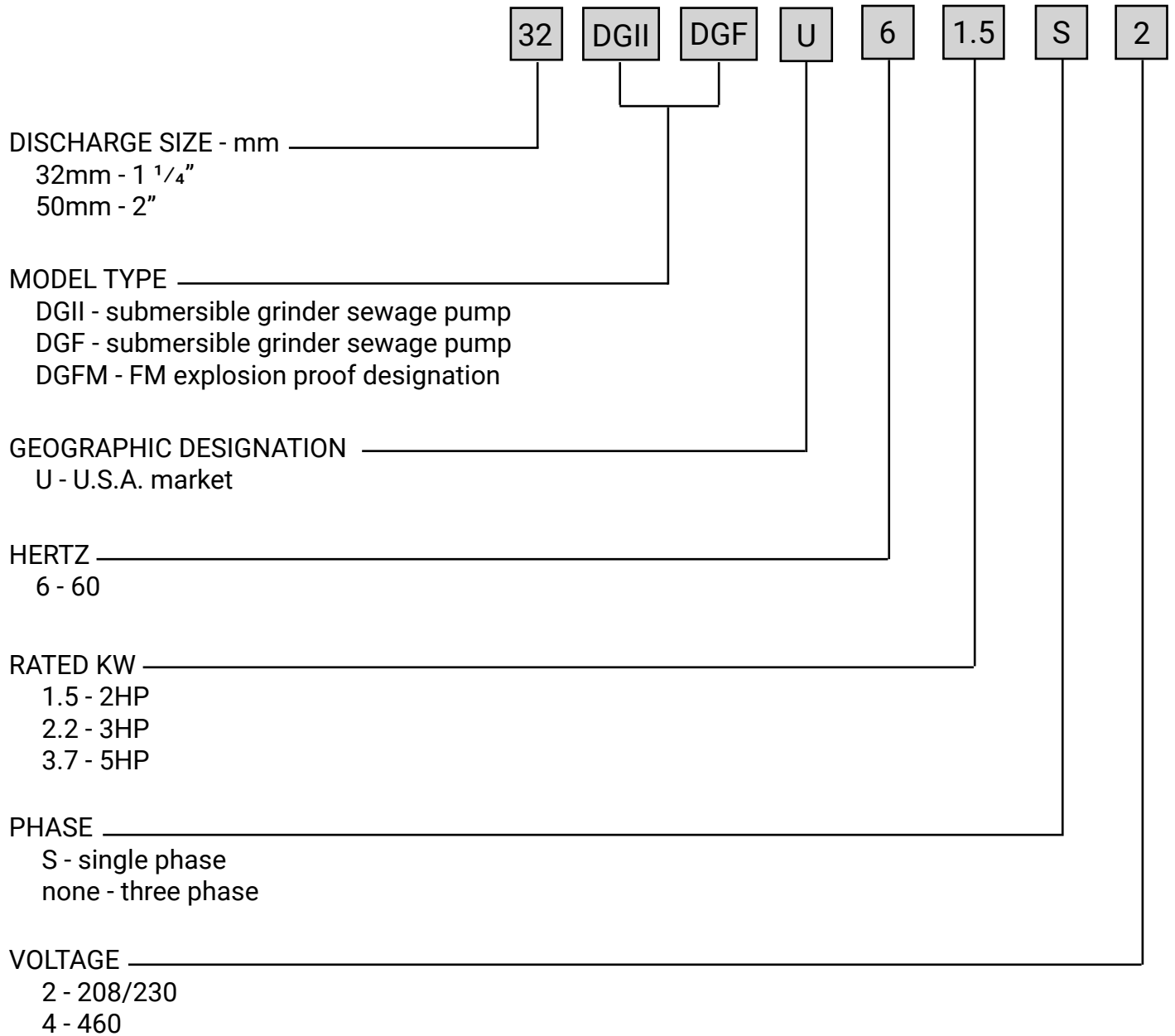

Specifications

Model DGUII
Specifications

	Standard	Optional
Size	1 1/4 inch	
Range of HP Range of Performance	2 HP Single Phase Capacity 5 to 30 GPM Head 27 to 112 feet	
Limitation Maximum Water Temperature	104°F (40°C)	
Synchronous Speed	3600 RPM	
Materials Casing Impeller Grinder Impeller Grinder Disk Shaft Motor Frame Fastener	Cast Iron Cast Iron 440C Stainless Steel 440C Stainless Steel 403 Stainless Steel Cast Iron 304 Stainless Steel	
Mechanical Seal Material - Upper Side Material - Lower Side Impeller Type Bearing - Upper/Lower Side Motor Single Phase Motor Protection Single Phase	Double Mechanical Seal Carbon/Ceramic Silicon Carbide/Silicon Carbide Vortex Impeller Prelubricated Ball Bearing Air-filled, Insulation Class F 208/230V Buit-in Auto Cut, overload, no load, out of phase, and single phasing protection	
	Submersible cable 33ft.	66 ft.
Accessories		QDC System



Selection Chart

Single Phase

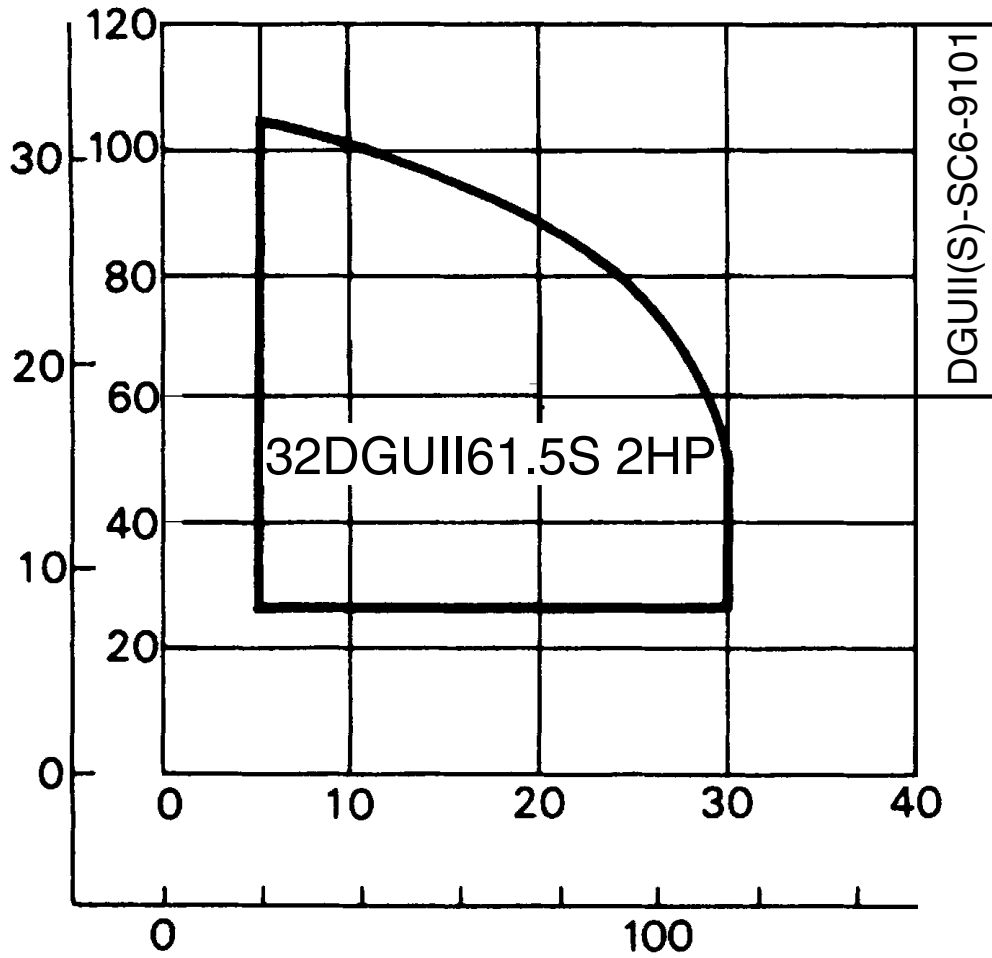

Specifications

Model DGFU
Specifications

	Standard	Optional
Size	1 1/4 inch, 2 inch	
Range of HP Range of Performance	2 to 5HP Single and Three Phase Capacity 5 to 80 GPM Head 27 to 148 feet	
Limitation Maximum Water Temperature	104°F (40°C)	
Synchronous Speed	3600 RPM	
Materials Casing Impeller Grinder Impeller Grinder Disk Shaft Motor Frame Fastener	Cast Iron Cast Iron 440C Stainless Steel 440C Stainless Steel 403 Stainless Steel Cast Iron 304 Stainless Steel	
Mechanical Seal Material - Upper Side Material - Lower Side Impeller Type Bearing - Upper/Lower Side Motor Single Phase Three Phase Motor Protection	Double Mechanical Seal Carbon/Ceramic Silicon Carbide/Silicon Carbide Vortex Impeller Prelubricated Ball Bearing Insulation Class F 208/230V 208/230/460V Built-in Thermal Detector - Kixon Built-in Mechanical Seal Leakage Detector -Float Switch Submersible cable 33ft.	FM Explosion Proof Class 1, Division 1, Group C, D ___ ft. (customer specified)
Accessories		QDC System



Selection Chart

Single and Three Phase

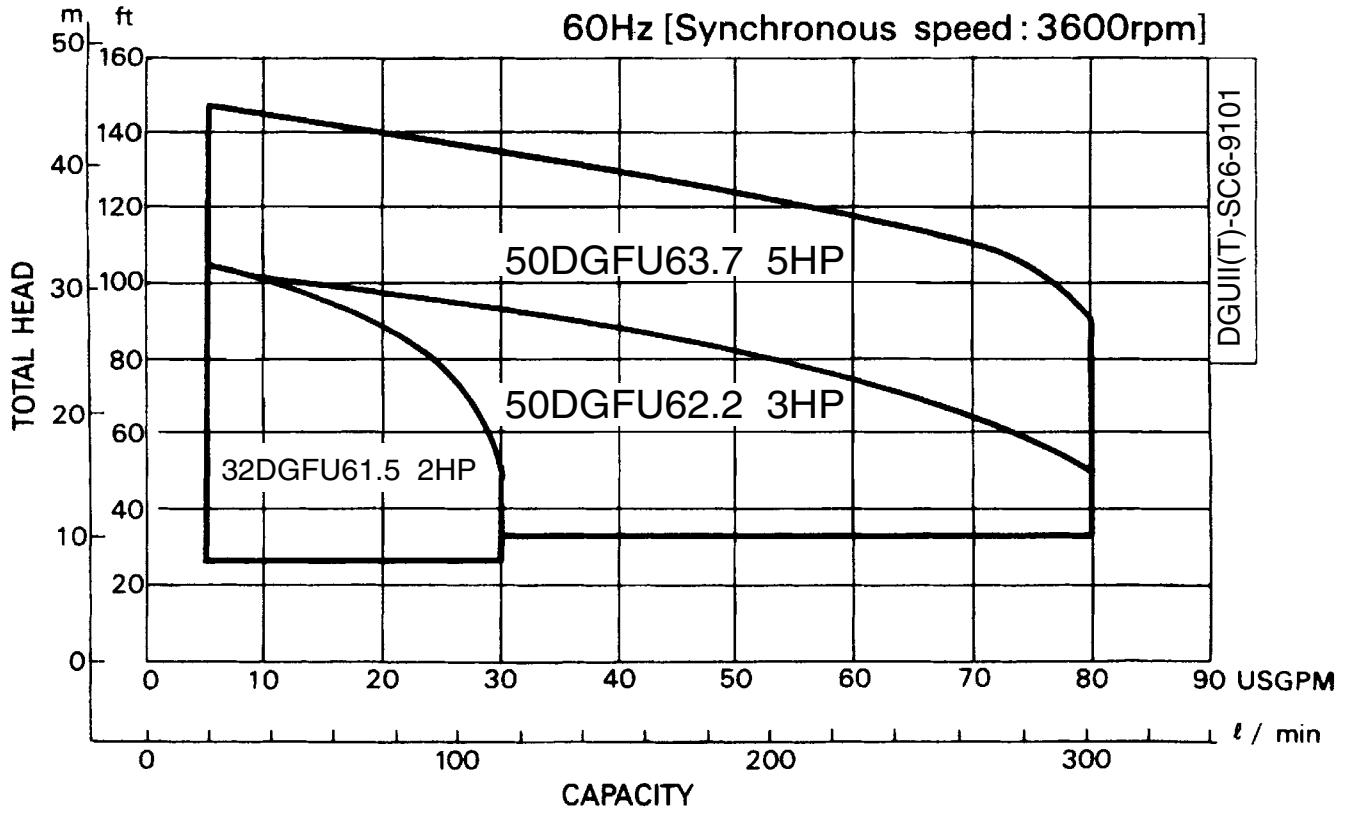

Specifications**A. General:**

Provide submersible grinder sewage pumps suitable for continuous duty operation underwater without loss of watertight integrity to a depth of 65 feet. Unit shall be designed with a grinder system to macerate material found in normal domestic and commercial sewage including reasonable amounts of wood chips, plastics, disposable diapers, sanitary napkins etc., to a fine slurry. If mounted on a guide rail system, design shall be such that the pump will be automatically connected to the discharge piping when lowered into place on the discharge connection. The pump shall be easily removable for inspection or service, requiring no bolts, nuts, or other fasteners to be disconnected, or the need for personnel to enter the wet well. The motor and pump shall be designed, manufactured, and assembled by the same manufacturer.

B. Manufacturer:

Ebara International Corporation

C. Pump Characteristics:

Pumps shall conform to the following requirements:

Number of units

Design flow (gpm)

Design TDH (ft)

Minimum shut off head (ft)

RPM 3600

Maximum HP 2

Minimum hydraulic efficiency at design (%)

Minimum power factor at design (%)

Voltage/HZ 208/230V / 60

Phase 1

D. Pump Construction:

All major parts of the pumping unit(s) including casing, impeller, motor frame and discharge elbow shall be manufactured from gray cast iron, ASTM A-48 Class 30. Castings shall have smooth surfaces devoid of blow holes or other casting irregularities. Casing design shall be centerline discharge with a large radius on the cut water to prevent clogging. Units shall be furnished with a discharge elbow and 125 lb. flat face 11/4" ANSI flange. All exposed bolts and nuts shall be 304 stainless steel. All mating surfaces of major components shall be machined and fitted with NBR o-rings where watertight sealing is required. Machining and fitting shall be such that sealing is accomplished by automatic compression of o-rings in two planes and o-ring contact is made on four surfaces without the requirement of specific torque limits. Internal and external surfaces are prepared to SPPC-VISI-SP-3-63 then coated with a zinc-chromate primer. The external surfaces are then coated with a H.B. Tnemecol 46-465 Coal Tar paint.

Impeller design shall be a recessed, semi-vortex, multi-vane design. It shall include back pump out vanes to reduce the pressure and entry of foreign materials into the mechanical seal area. Impellers shall be direct connected to the motor shaft with a slip fit, key driven, and secured behind the rotary grinder impeller and nut.

The grinder system shall consist of stationary cutter ring and rotary grinder impeller, each manufactured of 440C stainless steel with a minimum hardness of HRC 60. The rotary grinder impeller shall be direct connected to the motor shaft with a slip fit, key driven, and secured with an impeller nut. The pump suction shall be machined to accept the stationary cutter ring which is held in place by a disk cover plate which bolts to the casing.

Double mechanical seals operating in an oil bath shall be provided on all units. The oil filled seal chamber shall be designed to prevent over-filling and include an anti-vortexing vane to insure proper lubrication of both seal faces. Face materials shall be carbon/ceramic for the upper seal and silicon carbide for both lower seal faces. The elastomers shall be of NBR material and hardware shall be 304SS. Seal system shall not rely on pumping medium for lubrication.



Specifications**E. Motor Construction:**

The pump motor shall be an air filled induction type with a squirrel cage rotor, shell type design, built to NEMA MG-1, Design B specifications. Stator windings shall be copper, insulated with moisture resistant Class F insulation, rated for 311°F. The stator shall be dipped and baked three times in Class F varnish and heat shrunk fitted into the stator housing. Rotor bars and short circuit rings shall be manufactured of cast aluminum. Motor shaft shall be one piece AISI403 material, rotating on two permanently lubricated ball bearings designed for a minimum B-10 life of 60,000 hours. Upper bearing shall be a single ball type. Lower bearing shall be a double row angular contact ball type. Motor service factor shall be 1.15 and capable of up to 20 starts per hour. The motor shall be designed for continuous duty pumping at a maximum sump temperature of 104°F. Voltage and frequency tolerances shall be a maximum 10 / 5% respectively. Motor protection shall be provided by an auto-cut device located directly over the windings to provide protection from low voltage, locked rotor, and no load or run dry conditions. Motor shall be non-overloading over the entire performance curve and be able to operate at full load intermittently while unsubmerged without damage to the unit.

Power cable jacket shall be manufactured of an oil resistant chloroprene rubber material, designed for submerged applications. Cable shall be watertight to a depth of at least 65'. Cable entry shall be composed of a one piece, vulcanized, three way mechanical sealing system with a thick molded shoulder with increasing cable diameters to resist fatigue from bending forces. The molded shoulder, acts as the primary and secondary sealing points. This system shall also prevent leakage into the motor housing due to capillary action through the insulation if the cable is damaged or cut. A metallic plate shall be utilized to clamp the entry system to the motor housing. Strain relief shall be accomplished by clamping and attaching the cable with chain to the motor housing.

F. Guide Rail system:

Design shall include two (2) 304SS schedule 40 guide rails sized to mount directly to the quick discharge connector, QDC, at the floor of the wetwell and to a guide rail bracket at the top of the wetwell below the hatch opening, (refer to project drawings). Intermediate guide brackets are recommended for rail lengths over 15 feet.

Guide rails are not part of the pump package and shall be supplied by others.

The QDC shall be manufactured of cast iron, A48 Class 30. It shall be designed to adequately support the guide rails, discharge piping, and pumping unit under both static and dynamic loading conditions with support legs that are suitable for anchoring it to the wetwell floor. The face of the inlet QDC flange shall be perpendicular to the floor of the wetwell.

The pump design shall include an integral self-aligning sliding bracket. Sealing of the pumping unit to the QDC shall be accomplished by a single, linear, downward motion of the pump. The entire weight of the pump unit shall be guided to and wedged tightly against the inlet flange of the QDC, making metal to metal contact with the pump discharge forming a seal without the use of bolts, gaskets or o-rings.

A stainless steel lifting chain of adequate length for removing and installing the pump unit is recommended. The chain shall have a round link with a 2-1/4" inside diameter every two feet. This link will allow for a sliding pinch bar through the link to pick the chain, more than once if necessary, at multiple intervals during pump removal and installation.

Specifications

A. General:

Provide submersible grinder sewage pumps suitable for continuous duty operation underwater without loss of watertight integrity to a depth of 65 feet. Unit shall be designed with a grinder system to macerate material found in normal domestic and commercial sewage including reasonable amounts of wood chips, plastics, disposable diapers, sanitary napkins etc., to a fine slurry. If mounted on a guide rail system, design shall be such that the pump will be automatically connected to the discharge piping when lowered into place on the discharge connection. The pump shall be easily removable for inspection or service, requiring no bolts, nuts, or other fasteners to be disconnected, or the need for personnel to enter the wet well. The motor and pump shall be designed, manufactured, and assembled by the same manufacturer.

B. Manufacturer:

Ebara International Corporation

C. Pump Characteristics:

Pumps shall conform to the following requirements:

Number of units

Design flow (gpm)

Design TDH (ft)

Minimum shut off head (ft)

RPM

3600

Maximum HP

Minimum hydraulic efficiency at design (%)

Minimum power factor at design (%)

Voltage/HZ

208/230V / 60

Phase

D. Pump Construction:

All major parts of the pumping unit(s) including casing, impeller, motor frame and discharge elbow shall be manufactured from gray cast iron, ASTM A-48 Class 30. Castings shall have smooth surfaces devoid of blow holes or other casting irregularities. Casing design shall be centerline discharge with a large radius on the cut water to prevent clogging. Units shall be furnished with a discharge elbow and 125 lb. flat face ANSI flange. All exposed bolts and nuts shall be 304 stainless steel. All mating surfaces of major components shall be machined and fitted with NBR o-rings where watertight sealing is required. Machining and fitting shall be such that sealing is accomplished by automatic compression of o-rings in two planes and o-ring contact is made on four surfaces without the requirement of specific torque limits. Internal and external surfaces are prepared to SPCC-VISI-SP-3-63 then coated with a zinc-chromate primer. The external surfaces are then coated with a H.B. Tnemecol 46-465 Coal Tar paint.

Impeller design shall be a recessed, semi-vortex, multi-vane design. It shall include back pump out vanes to reduce the pressure and entry of foreign materials into the mechanical seal area. Impellers shall be direct connected to the motor shaft with a slip fit, key driven, and secured behind the rotary grinder impeller and nut.

The grinder system shall consist of stationary cutter ring and rotary grinder impeller, each manufactured of a 440C stainless steel with a minimum hardness of HRC 60. The rotary grinder impeller shall be direct connected to the motor shaft with a slip fit, key driven, and secured with an impeller nut. The pump suction shall be machined to accept the stationary cutter ring which is held in place by a disk cover plate which bolts to the casing.

Double mechanical seals operating in an oil bath shall be provided on all units. The oil filled seal chamber shall be designed to prevent over-filling and include an anti-vortexing vane to insure proper lubrication of both seal faces. Face materials shall be carbon/ceramic for the upper seal and silicon carbide for both lower seal faces. The elastomers shall be of NBR material and hardware shall be 304SS. Seal system shall not rely on pumping medium for lubrication.



Specifications**E. Motor Construction:**

The pump motor shall be an air filled induction type with a squirrel cage rotor, shell type design, built to NEMA MG-1, Design B specifications. Stator windings shall be copper, insulated with moisture resistant Class F insulation, rated or 311°F. The stator shall be dipped and baked three times in Class F varnish and heat shrunk fitted into the stator housing. Rotor bars and short circuit rings shall be manufactured of cast aluminum. Motor shaft shall be one piece AISI403 material, rotating on two permanently lubricated ball bearings designed for a minimum B-10 life of 60,000 hours. Upper bearing shall be a single ball type. Lower bearing shall be a double row angular contact ball type. Motor service factor shall be 1.15 and capable of up to 20 starts per hour. The motor shall be designed for continuous duty pumping at a maximum sump temperature of 104°F. Voltage and frequency tolerances shall be a maximum 10 / 5% respectively. Motor over temperature protection shall be provided by miniature thermal protectors embedded in the windings. Mechanical seal failure protection shall be provided by a mechanical float switch located in a chamber above the seal. This switch shall be comprised of a magnetic float that actuates a dry reed switch encapsulated within the stem. Should the mechanical seal fail, liquid shall be directed into the float chamber, in which the rising liquid activates the switch opening the normally closed circuit. The float body and float shall be a polypropylene material with a 316SS stopper. The motor shall be non-overloading over the entire performance curve and be able to operate at full load intermittently, while unsubmerged without damage to the unit.

Power cable jacket shall be manufactured of an oil resistant chloroprene rubber material, designed for submerged applications. Cable shall be watertight to a depth of at least 65'. The cable entry system shall comprise of primary, secondary, and tertiary sealing methods. The primary seal shall be achieved by a cylindrical elastomeric grommet compressed between the motor cover and a 304SS washer. Secondary sealing is accomplished with a compressed o-ring made of NBR material. Compression and subsequent sealing shall preclude specific torque requirements. The system shall also include tertiary sealing to prevent leakage into the motor housing due to capillary action through the insulation if the cable is damaged or cut. The cable wires shall be cut, stripped, re-connected with a copper butt end connector, and embedded in epoxy within the cable gland. This provides a dead end for leakage through the cable insulation into the motor junction area.

F. Guide Rail system:

Design shall include two (2) 304SS schedule 40 guide rails sized to mount directly to the quick discharge connector, QDC, at the floor of the wetwell and to a guide rail bracket at the top of the wetwell below the hatch opening, (refer to project drawings). Intermediate guide brackets are recommended for rail lengths over 15 feet.

Guide rails are not part of the pump package and shall be supplied by others.

The QDC shall be manufactured of cast iron, A48 Class 30. It shall be designed to adequately support the guide rails, discharge piping, and pumping unit under both static and dynamic loading conditions with support legs that are suitable for anchoring it to the wetwell floor. The face of the inlet QDC flange shall be perpendicular to the floor of the wetwell.

The pump design shall include an integral self-aligning sliding bracket. Sealing of the pumping unit to the QDC shall be accomplished by a single, linear, downward motion of the pump. The entire weight of the pump unit shall be guided to and wedged tightly against the inlet flange of the QDC, making metal to metal contact with the pump discharge forming a seal without the use of bolts, gaskets or o-rings.

A stainless steel lifting chain of adequate length for removing and installing the pump unit is recommended. The chain shall have a round link with a 2-1/4" inside diameter every two feet. This link will allow for a sliding pinch bar through the link to pick the chain, more than once if necessary, at multiple intervals during pump removal and installation.

Specifications

A. General:

Provide FM explosion proof submersible grinder sewage pumps suitable for continuous duty operation underwater without loss of watertight integrity to a depth of 65 feet. Unit shall be designed with a grinder system to macerate material found in normal domestic and commercial sewage including reasonable amounts of wood chips, plastics, disposable diapers, sanitary napkins etc., to a fine slurry. If mounted on a guide rail system, design shall be such that the pump will be automatically connected to the discharge piping when lowered into place on the discharge connection. Design and operation shall be non-sparking. The pump shall be easily removable for inspection or service, requiring no bolts, nuts, or other fasteners to be disconnected, or the need for personnel to enter the wet well. The motor and pump shall be designed, manufactured, and assembled by the same manufacturer.

B. Manufacturer:

Ebara International Corporation

C. Pump Characteristics:

Pumps shall conform to the following requirements:

Number of units	
Design flow (gpm)	
Design TDH (ft)	
Minimum shut off head (ft)	
RPM	3600
Maximum HP	
Minimum hydraulic efficiency at design (%)	
Minimum power factor at design (%)	
Voltage/HZ	208/230V, 460V / 60
Phase	

D. Pump Construction:

All major parts of the pumping unit(s) including casing, impeller, motor frame and discharge elbow shall be manufactured from gray cast iron, ASTM A-48 Class 30. Castings shall have smooth surfaces devoid of blow holes or other casting irregularities. Casing design shall be centerline discharge with a large radius on the cut water to prevent clogging. Units shall be furnished with a discharge elbow and 125 lb. flat face ANSI flange. All exposed bolts and nuts shall be 304 stainless steel. All mating surfaces of major components shall be machined and fitted with NBR o-rings where watertight sealing is required. Machining and fitting shall be such that sealing is accomplished by automatic compression of o-rings in two planes and o-ring contact is made on four surfaces without the requirement of specific torque limits. Internal and external surfaces are prepared to SPPC-VISI-SP-3-63 then coated with a zinc-chromate primer. The external surfaces are then coated with a H.B. Tnemecol 46-465 Coal Tar paint.

Impeller design shall be a recessed, semi-vortex, multi-vane design. It shall include back pump out vanes to reduce the pressure and entry of foreign materials into the mechanical seal area. Impellers shall be direct connected to the motor shaft with a slip fit, key driven, and secured behind the rotary grinder impeller and nut.

The grinder system shall consist of stationary cutter ring and rotary grinder impeller, each manufactured of a 440C stainless steel with a minimum hardness of HRC 60. The rotary grinder impeller shall be direct connected to the motor shaft with a slip fit, key driven, and secured with an impeller nut. The pump suction shall be machined to accept the stationary cutter ring which is held in place by a disk cover plate which bolts to the casing.

Double mechanical seals operating in an oil bath shall be provided on all units. The oil filled seal chamber shall be designed to prevent over-filling and include an anti-vortexing vane to insure proper lubrication of both seal faces. Face materials shall be carbon/ceramic for the upper seal and silicon carbide for both lower seal faces. The elastomers shall be of NBR material and hardware shall be 304SS. Seal system shall not rely on pumping medium for lubrication.



Specifications**E. Motor Construction:**

The pump motor shall be FM Explosion Proof, Class 1, Division 1, Groups C, D. The design shall be an air filled induction type with a squirrel cage rotor, shell type design, built to NEMA MG-1, Design B specifications. Stator windings shall be copper, insulated with moisture resistant Class F insulation, rated for 311°F. The stator shall be dipped and baked three times in Class F varnish and heat shrunk fitted into the stator housing. Rotor bars and short circuit rings shall be manufactured of cast aluminum. Motor shaft shall be one piece AISI403 material, rotating on two permanently lubricated ball bearings designed for a minimum B-10 life of 60,000 hours. Upper bearing shall be a single ball type. Lower bearing shall be a double row angular contact ball type. Motor service factor shall be 1.15 and capable of up to 20 starts per hour. The motor shall be designed for continuous duty pumping at a maximum sump temperature of 104°F. Voltage and frequency tolerances shall be a maximum 10 / 5% respectively. Motor over temperature protection shall be provided by Miniature thermal Protectors embedded in the windings. Mechanical seal failure protection shall be provided by a mechanical float switch located in a chamber above the seal. This switch shall be comprised of a magnetic float that actuates a dry reed switch encapsulated within the stem. Should the mechanical seal fail, liquid shall be directed into the float chamber, in which the rising liquid activates the switch opening the normally closed circuit. The float body and float shall be a polypropylene material with a 316SS stopper. The motor shall be non-overloading over the entire performance curve and be able to operate at full load intermittently, while unsubmerged without damage to the unit.

The power cable jacket shall be manufactured of an oil resistant chloroprene rubber material, designed for submerged applications. Cable shall be watertight to a depth of at least 65'. The cable entry system shall comprise of primary, secondary, and tertiary sealing methods. The primary seal shall be achieved by a cylindrical elastomeric grommet compressed between the motor cover and a 304SS washer. Secondary sealing is accomplished with a compressed o-ring made of NBR material. Compression and subsequent sealing shall preclude specific torque requirements. The system shall also include tertiary sealing to prevent leakage into the motor housing due to capillary action through the insulation if the cable is damaged or cut. The cable wires shall be cut, stripped, re-connected with a copper butt end connector, and embedded in epoxy within the cable gland. This provides a dead end for leakage through the cable insulation into the motor junction area.

F. Guide Rail System:

Design shall include two (2) 304SS schedule 40 guide rails sized to mount directly to the quick discharge connector, QDC, at the floor of the wetwell and to a guide rail bracket at the top of the wetwell below the hatch opening, (refer to project drawings). Intermediate guide brackets are recommended for rail lengths over 15 feet.

Guide rails are not part of the pump package and shall be supplied by others.

The QDC shall be manufactured of cast iron, A48 Class 30. It shall be designed to adequately support the guide rails, discharge piping, and pumping unit under both static and dynamic loading conditions with support legs that are suitable for anchoring it to the wetwell floor. The face of the inlet QDC flange shall be perpendicular to the floor of the wetwell.

The pump design shall include an integral self-aligning sliding bracket. Sealing of the pumping unit to the QDC shall be accomplished by a single, linear, downward motion of the pump. The entire weight of the pump unit shall be guided to and wedged tightly against the inlet flange of the QDC, making metal to metal contact with the pump discharge forming a seal without the use of bolts, gaskets or o-rings. Operation shall be non sparking by design.

A stainless steel lifting chain of adequate length for removing and installing the pump unit is recommended. The chain shall have a round link with a 2-1/4" inside diameter every two feet. This link will allow for a sliding pinch bar through the link to pick the chain, more than once if necessary, at multiple intervals during pump removal and installation.

Performance Curves

32DGUII61.5S

(2HP) Synchronous Speed: 3600 RPM

1 1/4 inch Discharge

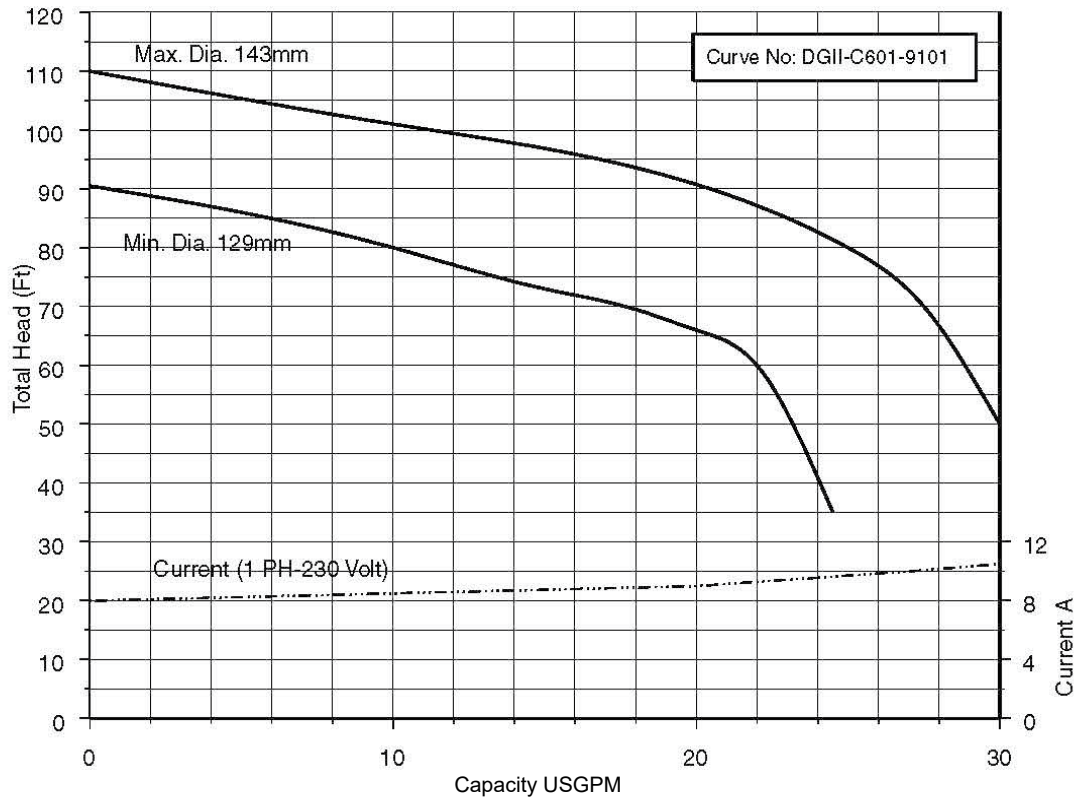

32DGFU61.5S

(2HP) Synchronous Speed: 3600 RPM

1 1/4 inch Discharge

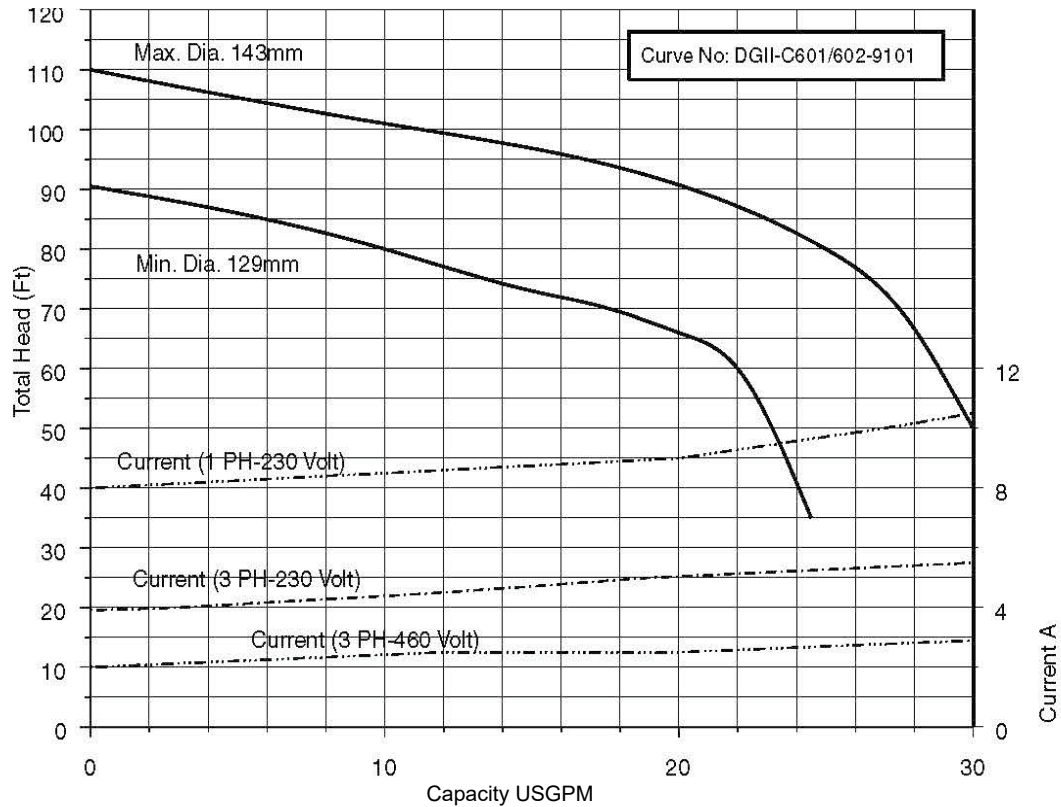

32DGFU61.5

(2HP) Synchronous Speed: 3600 RPM

1 1/4 inch Discharge

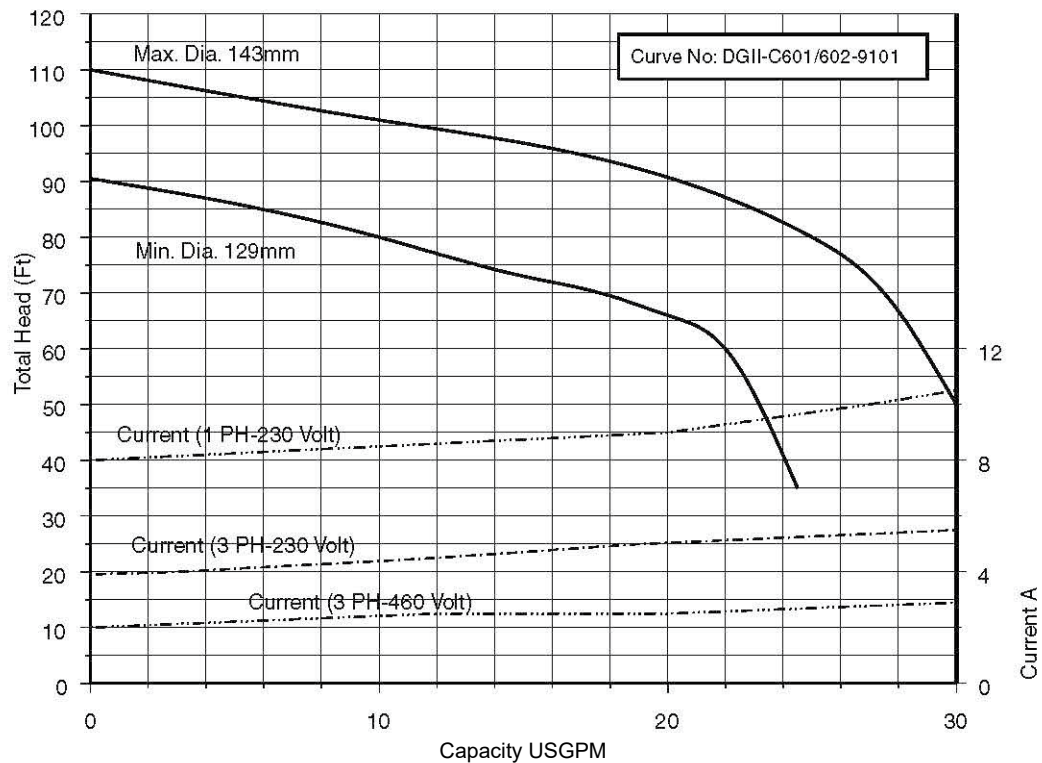

Performance Curves

50DGFU62.2S

(2HP) Synchronous Speed: 3600 RPM

2 inch Discharge

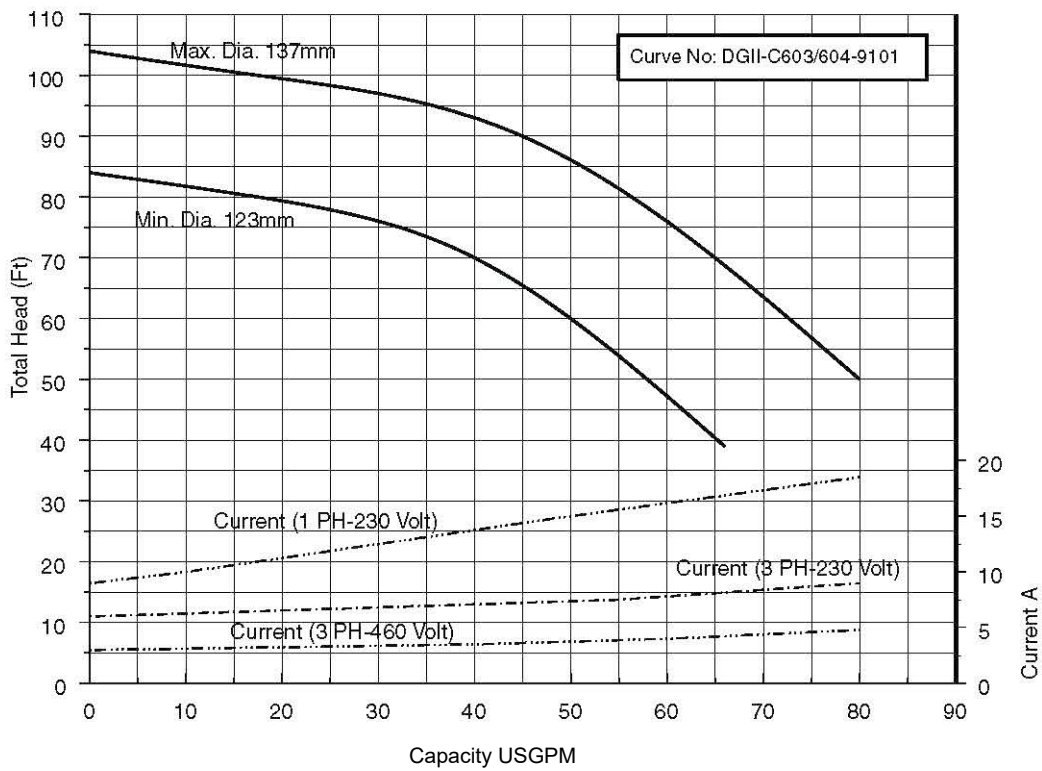

50DGFU62.2

(2HP) Synchronous Speed: 3600 RPM

2 inch Discharge

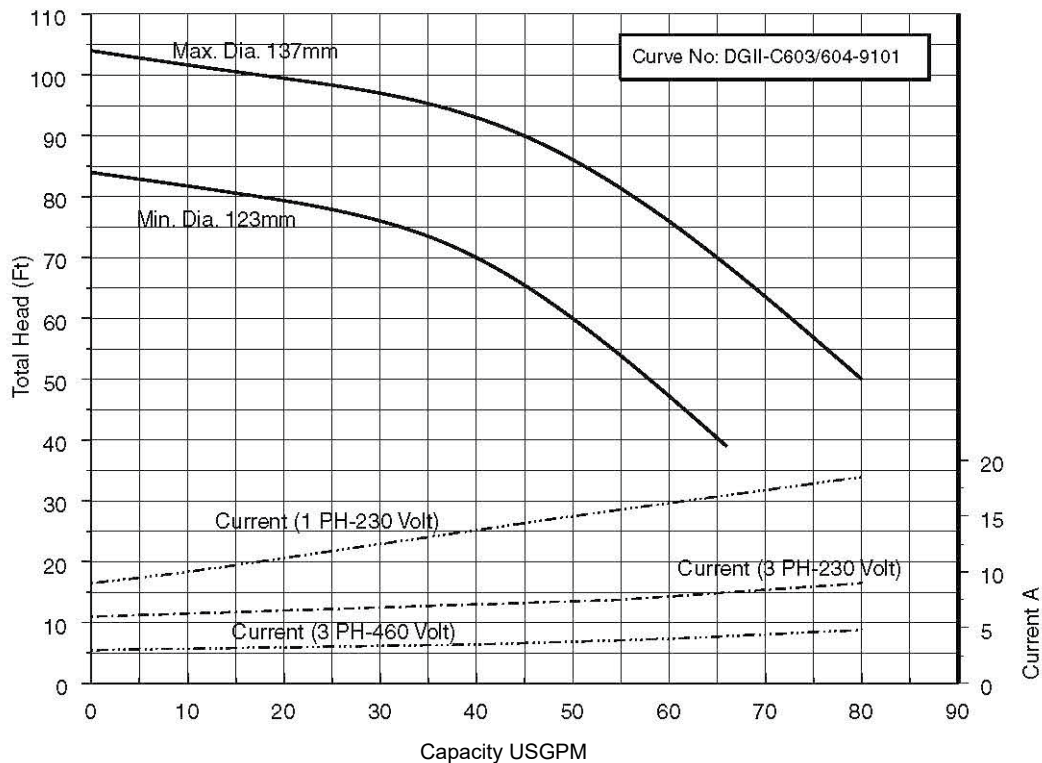

50DGFU63.7S

(2HP) Synchronous Speed: 3600 RPM

2 inch Discharge

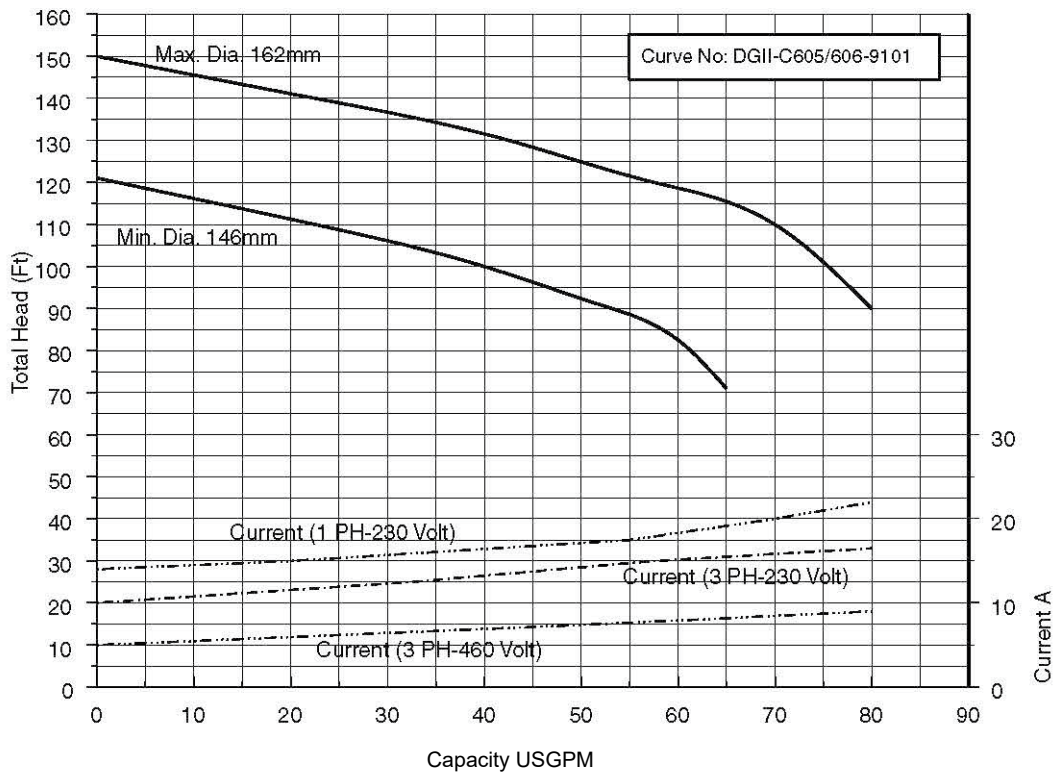

50DGFU63.7

(2HP) Synchronous Speed: 3600 RPM

2 inch Discharge

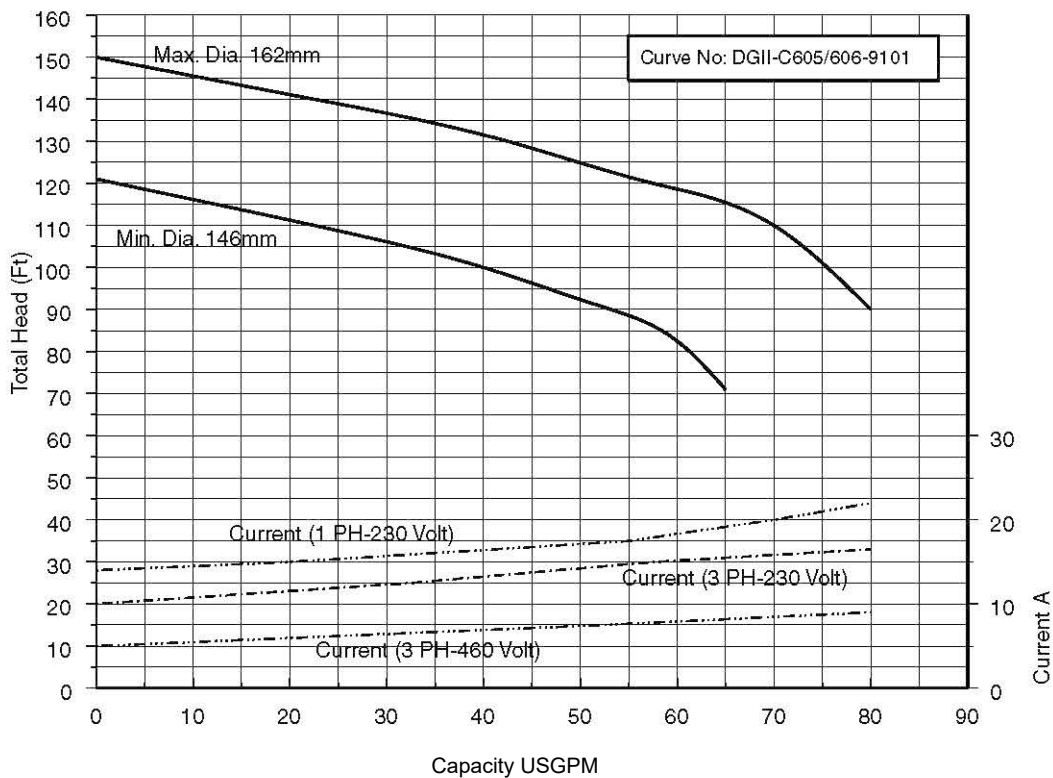

Dimensions

Model DGFU, Single and Three Phase

32DGFU, 2HP

50DGFU, 3 to 5HP

Unit: Inch (mm)

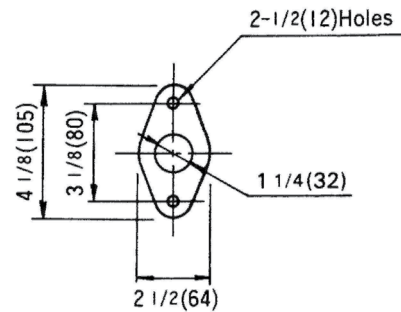
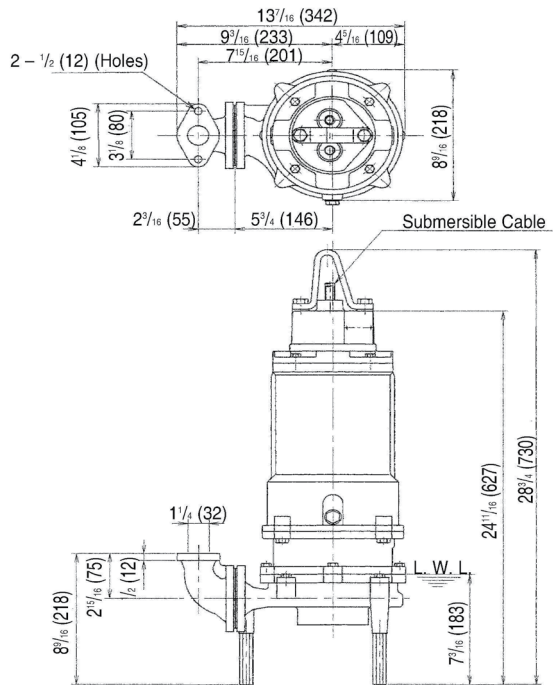

Flange

Model	Weight (Lb/Kg)
32DGFU61.5S	126 (57)
32DGFU61.5	128 (58)

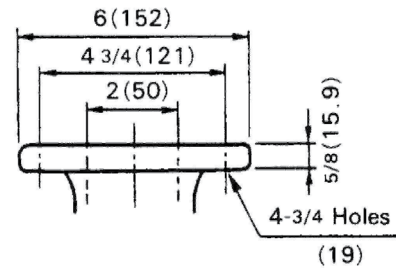
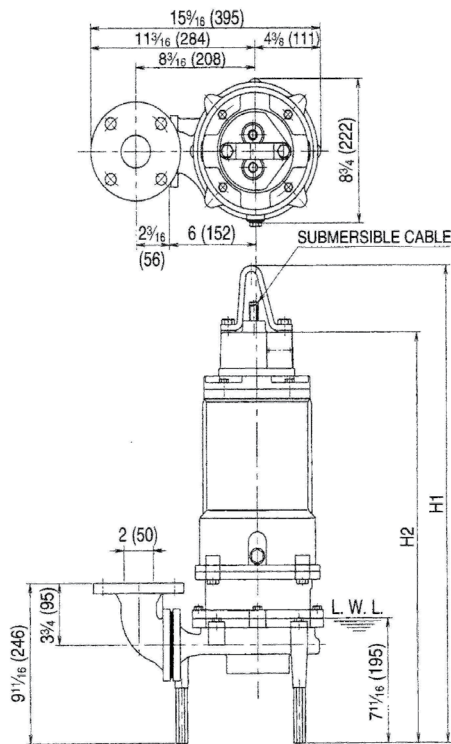

Flange (ANSI 125 PSI F.F)

Phase	Model	PUMP & MOTOR		Weight (Lb/Kg)
		H ₁ inch (mm)	H ₂ inch (mm)	
SINGLE	50DGFU62.2S	31 11/16 (805)	27 5/8 (702)	174 (79)
	50DGFU63.7S	35 11/16 (907)	31 5/8 (804)	223 (101)
THREE	50DGFU62.2	30 1/8 (765)	26 1/16 (662)	159 (72)
	50DGFU63.7	31 11/16 (805)	27 5/8 (702)	174 (79)



Dimensions

Model DGUII with Quick Discharge Connector, Single Phase
32DGUII, 2HP

Flange

LM50

Unit : Inch (mm)

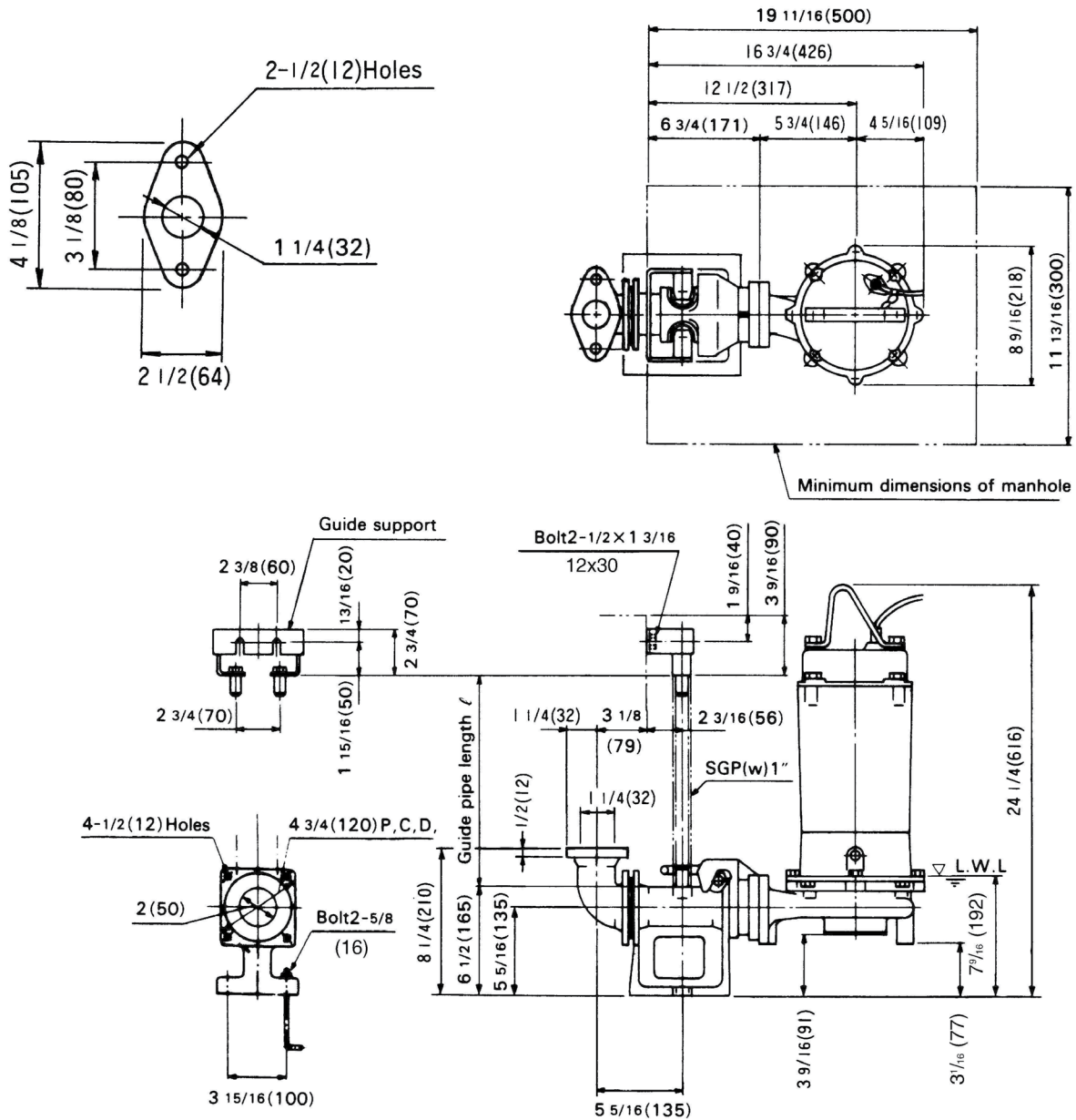

PHASE	MODEL	WEIGHT (Lb)		WEIGHT (kg)	
		Pump	Q.D.C	Pump	Q.D.C
SINGLE	32DGUII61.5S	93	24	42	11



Dimensions

Model DGFU with Quick Discharge Connector, Single and Three Phase
32DGFU, 2HP

LM50

Unit : Inch (mm)

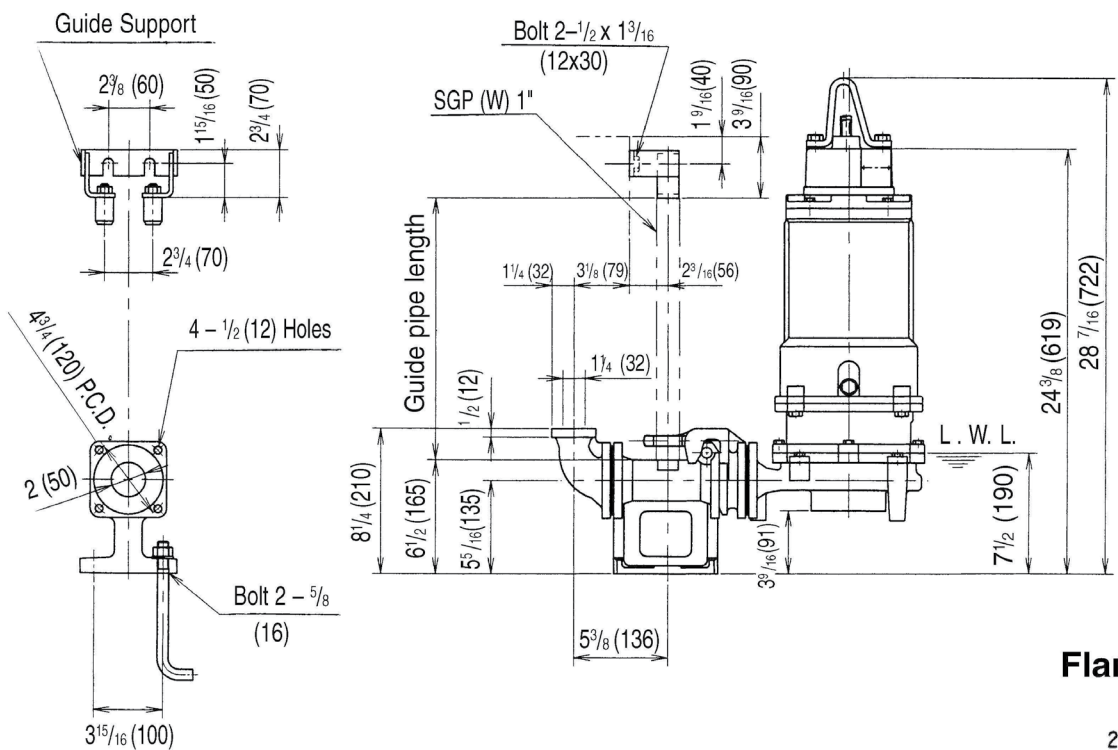
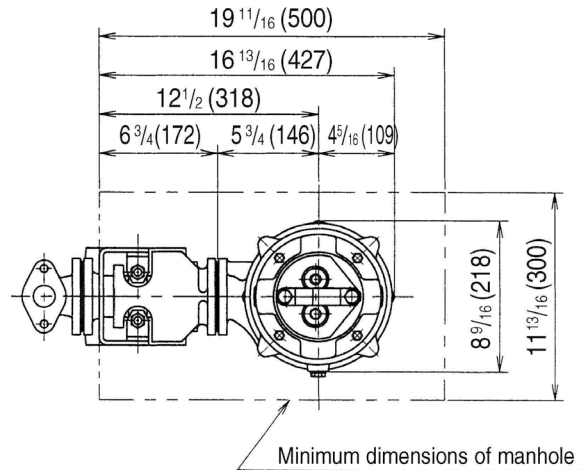

Flange

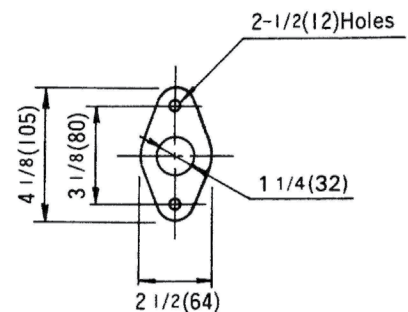

PHASE	MODEL	WEIGHT (Lb)		WEIGHT (kg)	
		Pump	Q.D.C	Pump	Q.D.C
SINGLE	32DGFU61.5S	126	24	57	11
THREE	32DGFU61.5	128	24	58	11



Dimensions

Model DGFU with Quick Discharge Connector, Single and Three Phase
50DGFU, 3 to 5HP

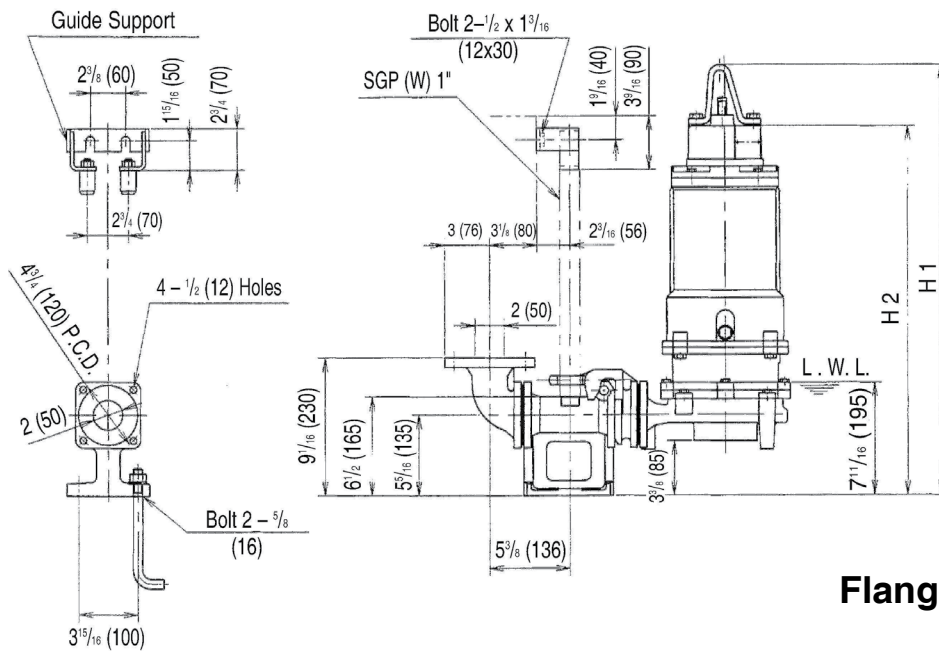
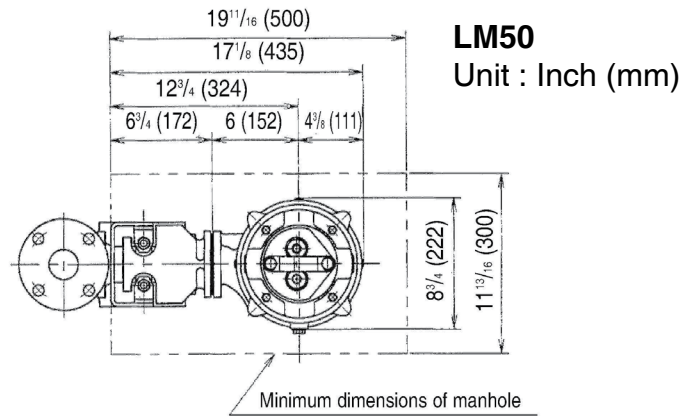

Flange (ANSI 125 PSI F.F)

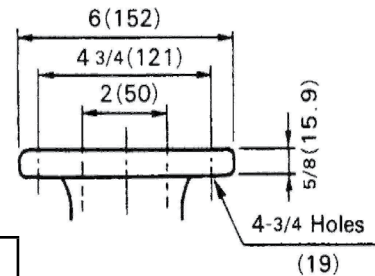

PHASE	MODEL	PUMP & MOTOR		WEGHT Lb (kg)	
		H ₁ inch (mm)	H ₂ inch (mm)	Pump	Q.D.C
SINGLE	50DGFU62.2S	31 1/16 (789)	27 (686)	174 (79)	24 (11)
	50DGFU63.7S	35 1/16 (891)	31 (788)	223 (101)	24 (11)
THREE	50DGFU62.2	29 1/2 (749)	25 7/16 (646)	159 (72)	24 (11)
	50DGFU63.7	31 1/16 (789)	27 (686)	174 (79)	24 (11)

Sectional View

**Single Phase
32DGUII**

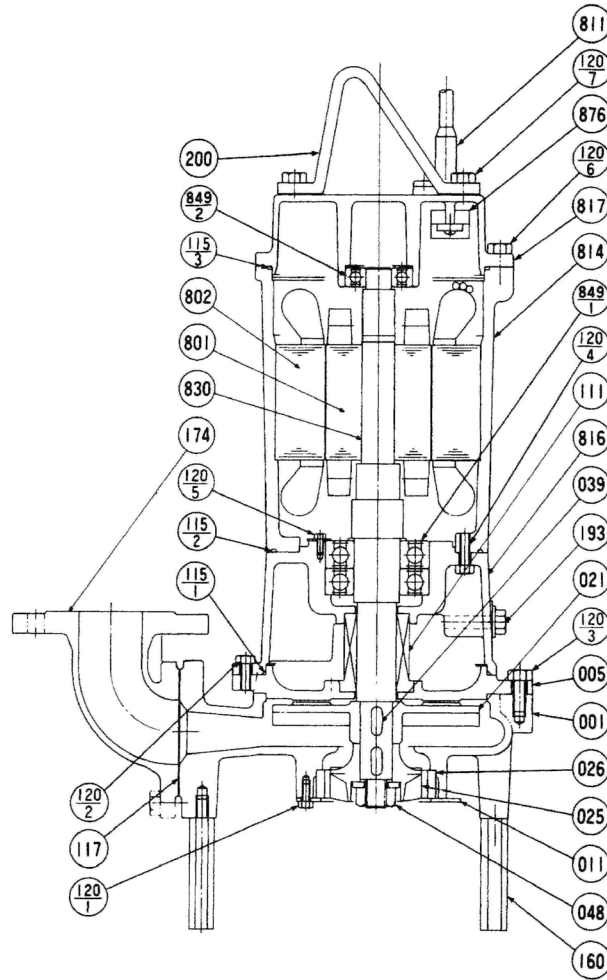

Part No.	Part Name	Material	ASTM, AISI Code	No. For 1 Unit
001	Casing	Cast Iron	A48 Class 30	1
005	Intermediate Casing	Cast Iron	A48 Class 30	1
011	Disk Cover	304 Stainless	AISI304	1
†021	Impeller	Cast iron	A48 Class 30	1
†025	Grinder Impeller	440C Stainless		1
†026	Cutter Ring	440C Stainless		1
039	Key	420 Stainless	AISI420	2
048	Impeller Nut	304 Stainless	AISI304	1
†111	Mechanical Seal	-		1 SET
†115-1	O-Ring	Rubber (NBR)		1
†115-2	O-Ring	Rubber (NBR)		1
†115-3	O-Ring	Rubber (NBR)		1
†117	Gasket			1
120-1	Bolt	304 Stainless	AISI304	4
120-2	Bolt	304 Stainless	AISI304	4
120-3	Bolt	304 Stainless	AISI304	4
120-4	Bolt	304 Stainless	AISI304	4

Part No.	Part Name	Material	ASTM, AISI, Code	No. For 1 Unit
120-5	Bolt	304 Stianless	AISI304	2
120-6	Bolt	304 Stainless	AISI304	4
120-7	Bolt	304 Stainless	AISI304	2
160	Pump Stand	Steel	A283 Grade D	3
174	Discharge Elbow	Cast Iron	A48 Class 30	1
193	Oil Plug	304 Stainless	AISI304	1
200	Liftnr Hanger	Steel	A283 Grade D	1
801	Rotor	-		1
802	Stator	-		1
†811	Submersible Cable	-		1
814	Motor Frame	Cast Iron	A48 Class 30	1
816	Bracket	Cast Iron	A48 Class 30	1
817	Bracket	Cast Iron	A48 Class 30	1
830	Shaft	403 Stainless	AISI 403	1
†849-1	Ball Bearing	-		1
†849-2	Ball Bearing	-		1
876	Motor Protector	-		1

Motors are purchased as a complete unit
†: REcommended spare parts



Sectional View

Single and Three Phase

32DGFU, 2HP

50DGFU 3 to 5HP

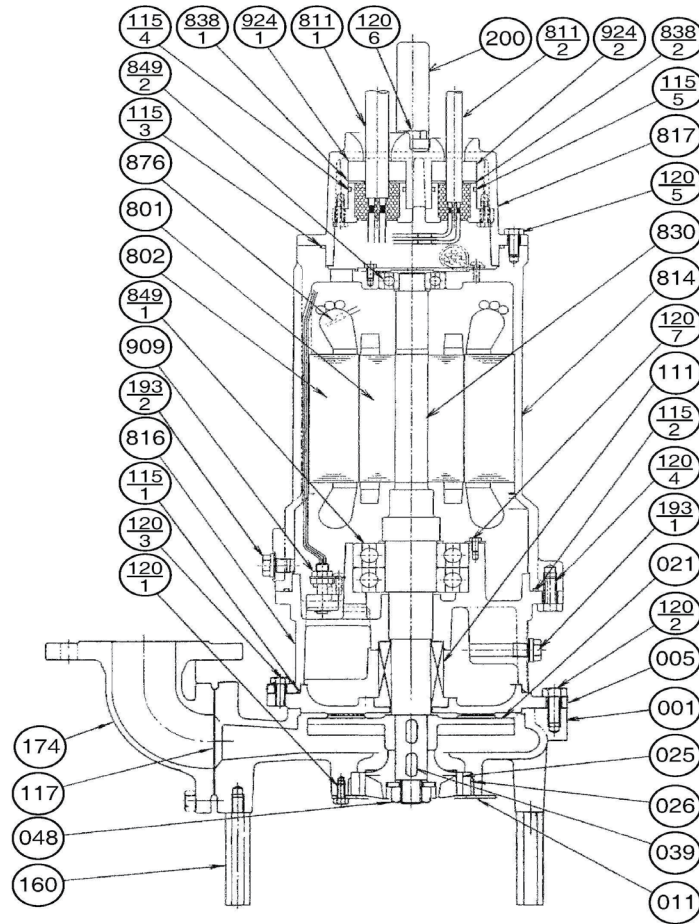

Part No.	Part Name	Material	ASTM, AISI Code	No. For 1 Unit
001	Casing	Cast Iron	A48 Class 30	1
005	Intermediate Casing	Cast Iron	A48 Class 30	1
011	Disk Cover	304 Stainless	AISI304	1
†021	Impeller	Cast iron	A48 Class 30	1
†025	Grinder Impeller	440C Stainless		1
†026	Cutter Ring	440C Stainless		1
039	Key	420 Stainless	AISI420	2
048	Impeller Nut	304 Stainless	AISI304	1
†111	Mechanical Seal	-		1 SET
†115-1	O-Ring	Rubber (NBR)		1
†115-2	O-Ring	Rubber (NBR)		1
†115-3	O-Ring	Rubber (NBR)		1
†115-4	O-Ring	Rubber (NBR)		
†115-5	O-Ring	Rubber (NBR)		
†117	Gasket			1
120-1	Bolt	304 Stainless	AISI304	4
120-2	Bolt	304 Stainless	AISI304	4
120-3	Bolt	304 Stainless	AISI304	4
120-4	Bolt	304 Stainless	AISI304	4
120-5	Bolt	304 Stainless	AISI304	4
120-6	Bolt	304 Stainless	AISI304	2
120-7	Bolt	304 Stainless	AISI304	3

Part No.	Part Name	Material	ASTM, AISI Code	No. For 1 Unit
160	Pump Stand	Steel	A283 Grade D	3
174	Discharge Elbow	Cast Iron	A48 Class 30	1
193-1	Oil Plug	304 Stainless	AISI304	1
193-2	Oil Plug	304 Stainless	AISI304	1
200	Liftnng Hanger	Steel	A283 Grade D	1
801	Rotor	-		1
802	Stator	-		1
811-1	Power Cable	-		1
811-2	Control Cable	-		1
814	Motor Frame	Cast Iron	A48 Class 30	1
816	Bracket	Cast Iron	A48 Class 30	1
817	Bracket	Cast Iron	A48 Class 30	1
830	Shaft	403 Stainless	AISI 403	1
838-1	Washer	304 Stainless	AISI304	1
838-2	Washer	304 Stainless	AISI304	1
†849-1	Ball Bearing	-		1 SET
†849-2	Ball Bearing	-		1
876	Motor Protector	-		3
909	Leakage Detector	-		1
924-1	Packing	Rubber (NBR)		1
924-2	Packing	Rubber (NBR)		1

