

Submersible Wastewater Pump with Anti-Clog Technology

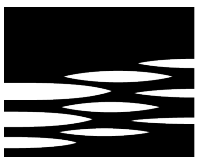

Model DKEU
Model DKEXU

Parts Reference



EBARA

EBARA Pumps Americas Corporation

Sectional View

View selection by model

Discharge	Model	Power		View	
		HP	kW	Std	Opt
50	50DKE(X)U461.5	2	1.5	1	2
80	80DKE(X)U461.5	2	1.5	1	2
	80DKE(X)U462.2	3	2.2	1	2
	80DKE(X)U463.7	5	3.7	1	2
	80DKE(X)U465.5	7.5	5.5	3	-
	80DKE(X)U467.5	10	7.5	3	-
	80DKE(X)U4611	15	11	3	-
	100DKE(X)U462.2	3	2.2	1	2
100DKE(X)U463.7	5	3.7	1	2	
100DKE(X)U465.5	7.5	5.5	4	-	
100DKEB(X)U465.5			6	-	
100DKE(X)U467.5	10	7.5	4	-	
100DKEB(X)U467.5			6	-	
100DKE(X)U4611	15	11	4	-	
100DKEB(X)U4611			3	-	
100DKE(X)U4615	20	15	5	-	
100DKEB(X)U4615			6	-	
100DKE(X)U4618	25	18.5	3	-	
100DKEB(X)U4618			3	-	
100DKE(X)U4622	30	22	3	-	
100DKEB(X)U4622			3	-	
100DKE(X)U4630	40	30	7	-	
100DKE(X)U4637	50	37	7	-	
100DKE(X)U4645	60	45	7	-	

Discharge	Model	Power		View		
		HP	kW	Std	Opt	
150	150DKE(X)U467.5	10	7.5	4	-	
	150DKE(X)U4611	15	11	4	-	
	150DKE(X)U4615	20	15	5	-	
	150DKE(X)U4618	25	18.5	4	-	
	150DKE(X)U4622	30	22	4	-	
	150DKE(X)U4630	40	30	8	-	
	150DKEB(X)U4630			8	-	
	150DKE(X)U4637	50	37	8	-	
	150DKEB(X)U4637			8	-	
	150DKEB(X)U4645	60	45	8	-	
	150DKE(X)U4645			8	-	
	200	200DKE(X)U4611	15	11	4	-
		200DKE(X)U4615	20	15	5	-
		200DKE(X)U4618	25	18.5	4	-
200DKE(X)U4622		30	22	4	-	
200DKE(X)U4630		40	30	8	-	
200DKE(X)U4637		50	37	8	-	
200DKE(X)U4645		60	45	8	-	
250DKE(X)U4618		25	18.5	4	-	
250DKE(X)U4622	30	22	4	-		
250DKE(X)U4630	40	30	8	-		
250DKE(X)U4637	50	37	8	-		
250DKE(X)U4645	60	45	8	-		



Sectional View

View 1

50DKE(X)U 2HP,
80DKE(X)U 2 to 5HP,
100DKE(X)U 2 to 5HP.

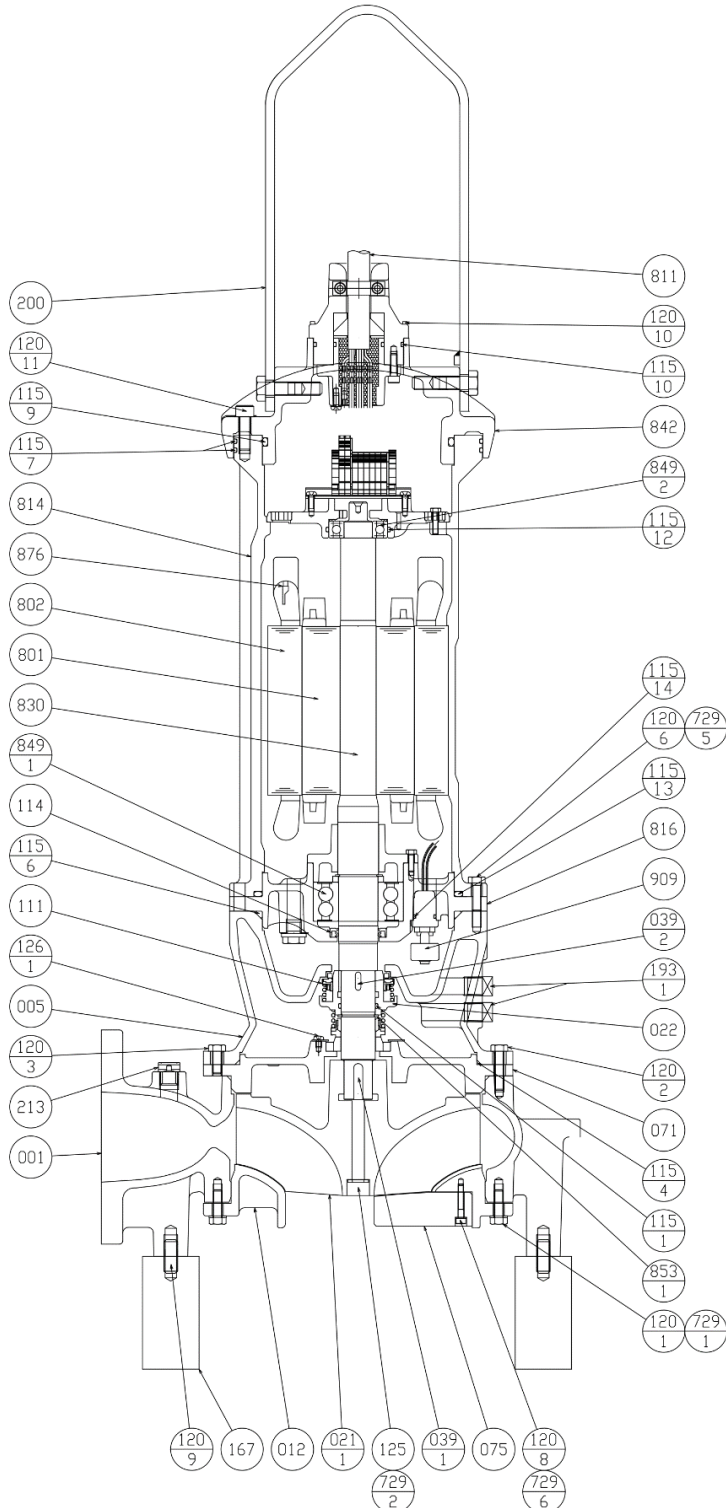

Item Number	Part Name	Material	Qty per unit
001	Pump Casing	Cast Iron(FC250)	1
005	Intermediate Casing	Cast Iron(FC200)	1
012	Suction Cover	Cast Iron(FC250)	1
021-1	Pump Impeller	Cast Iron(FC250)	1
022	Mechanical Seal Sleeve	Stainless Steel (SCS13)	1
039-1	Key	Stainless Steel (SUS420)	1
039-2	Key	Stainless Steel (SUS316)	1
071	Side Plate	Cast Iron(FC250)	1
075	Guide Pin	Ductile Cast Iron (FCD400)	1
111	Mechanical Seal	-	1 set
114	Oil Seal	-	1
115-1	O-Ring	NBR	1
115-4	O-Ring	NBR	1
115-6	O-Ring	NBR	1
115-7	O-Ring	NBR	2
115-9	O-Ring	NBR	1
115-10	O-Ring	NBR	1
115-12	O-Ring	NBR	1
115-13	O-Ring	NBR	1
115-14	O-Ring	NBR	1
120-1	Bolt	Stainless Steel (SUS304)	4 or 8
120-2	Bolt	Stainless Steel (SUS304)	4 or 8
120-3	Bolt	Stainless Steel (SUS304)	4
120-6	Bolt	Stainless Steel (SUS304)	4
120-8	Bolt	Stainless Steel (SUS304)	2
120-9	Bolt	Stainless Steel (SUS304)	3
120-10	Bolt	Stainless Steel (SUS304)	4
120-11	Bolt	Stainless Steel (SUS304)	4
125	Impeller Bolt	Stainless Steel (SUS304)	1
126-1	Screw	Stainless Steel (SUS304)	3
167	Pump Leg	Steel (SS400)	3
193-1	Plug	Stainless Steel (SUS304)	2
200	Lifting Hanger	Stainless Steel (SUS304)	1
213	Air Vent Valve	Brass (C3604)	1
729-1	Spring Washer	Stainless Steel (SUS304)	4 or 8
729-2	Spring Washer	Stainless Steel (SUS304)	1
729-5	Spring Washer	Stainless Steel (SUS304)	4
729-6	Spring Washer	Stainless Steel (SUS304)	2
800	Motor	-	1
811	Submersible Cable	-	1
814	Motor Frame	Cast Iron(FC200)	1
816	Power Side Braket	Cast Iron(FC200)	1
830	Shaft	Stainless Steel (SUS403)	1
842	Motor Cover	Cast Iron(FC200)	1
849-1	Ball Bearing	-	1
849-2	Ball Bearing	-	1
853-1	C-Type Snap Ring	-	1
876	Thermal Protector	-	3
909	Leakage Detector	-	1



Sectional View

View 2

50DKE(X)U 2HP,
80DKE(X)U 2 to 5HP,
100DKE(X)U 2 to 5HP.

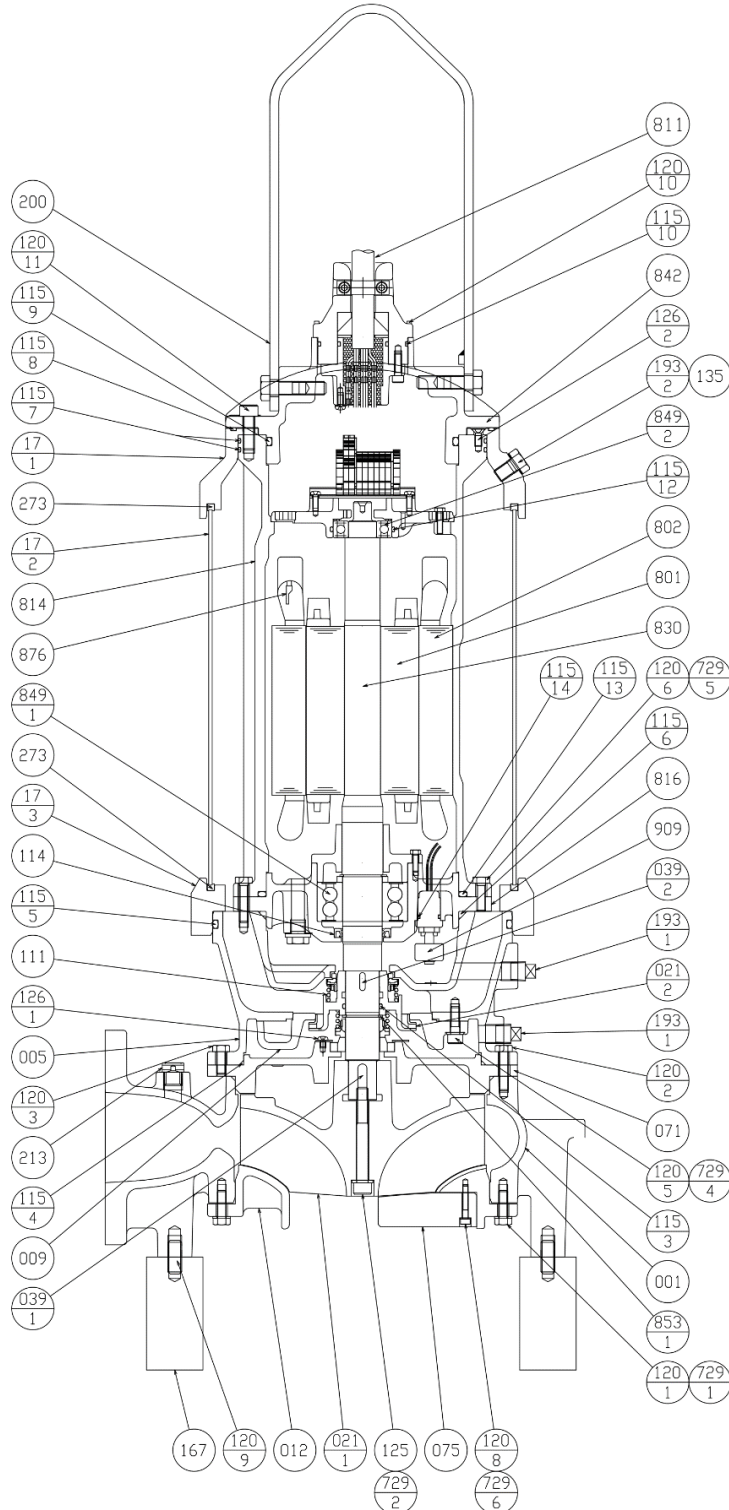

Item Number	Part Name	Material	Qty per unit
001	Pump Casing	Cast Iron(FC250)	1
005	Intermediate Casing	Cast Iron(FC200)	1
009	Inner Casing	Cast Iron(FC200)	1
012	Suction Cover	Cast Iron(FC250)	1
017-1	Upper Cover	Cast Iron(FC250)	1
017-2	Jacket Body	Stainless Steel (SUS304)	1
017-3	Bottom Ring	Cast Iron(FC250)	1
021-1	Pump Impeller	Cast Iron(FC250)	1
021-2	ICS Impeller	Stainless Steel (SCS13)	1
039-1	Key	Stainless Steel (SUS420)	1
039-2	Key	Stainless Steel (SUS316)	1
071	Side Plate	Cast Iron(FC250)	1
075	Guide Pin	Ductile Cast Iron (FCD400)	1
111	Mechanical Seal	-	1 set
114	Oil Seal	-	1
115-3	O-Ring	NBR	1
115-4	O-Ring	NBR	1
115-5	O-Ring	NBR	1
115-6	O-Ring	NBR	1
115-7	O-Ring	NBR	2
115-8	O-Ring	NBR	1
115-9	O-Ring	NBR	1
115-10	O-Ring	NBR	1
115-12	O-Ring	NBR	1
115-13	O-Ring	NBR	1
115-14	O-Ring	NBR	1
120-1	Bolt	Stainless Steel (SUS304)	4 or 8
120-2	Bolt	Stainless Steel (SUS304)	4 or 8
120-3	Bolt	Stainless Steel (SUS304)	4
120-5	Bolt	Stainless Steel (SUS304)	4
120-6	Bolt	Stainless Steel (SUS304)	4
120-8	Bolt	Stainless Steel (SUS304)	2
120-9	Bolt	Stainless Steel (SUS304)	3
120-10	Bolt	Stainless Steel (SUS304)	4
120-11	Bolt	Stainless Steel (SUS304)	4
125	Impeller Bolt	Stainless Steel (SUS304)	1
126-1	Screw	Stainless Steel (SUS304)	3
126-2	Countersunk Screw	Stainless Steel (SUS304)	4
135	Seal Washer	-	2
167	Pump Leg	Steel (SS400)	3
193-1	Plug	Stainless Steel (SUS304)	2
193-2	Plug	Stainless Steel (SUS304)	2
200	Lifting Hanger	Stainless Steel (SUS304)	1
213	Air Vent Valve	Brass (C3604)	1
273	Seal Packing	NBR	2
729-1	Spring Washer	Stainless Steel (SUS304)	4 or 8
729-2	Spring Washer	Stainless Steel (SUS304)	1
729-4	Spring Washer	Stainless Steel (SUS304)	4
729-5	Spring Washer	Stainless Steel (SUS304)	4
729-6	Spring Washer	Stainless Steel (SUS304)	2
800	Motor	-	1
811	Submersible Cable	-	1
814	Motor Frame	Cast Iron(FC200)	1
816	Power Side Braket	Cast Iron(FC200)	1
830	Shaft	Stainless Steel (SUS403)	1
842	Motor Cover	Cast Iron(FC200)	1
849-1	Ball Bearing	-	1
849-2	Ball Bearing	-	1
853-1	C-Type Snap Ring	-	1
876	Thermal Protector	-	3
909	Leakage Detector	-	1



Sectional View

View 3

80DKE(X)U 7.5 TO 15HP,
 100DKEB(X)U 15, 25 to 30HP,
 100DKE(X)U 25 to 30HP.

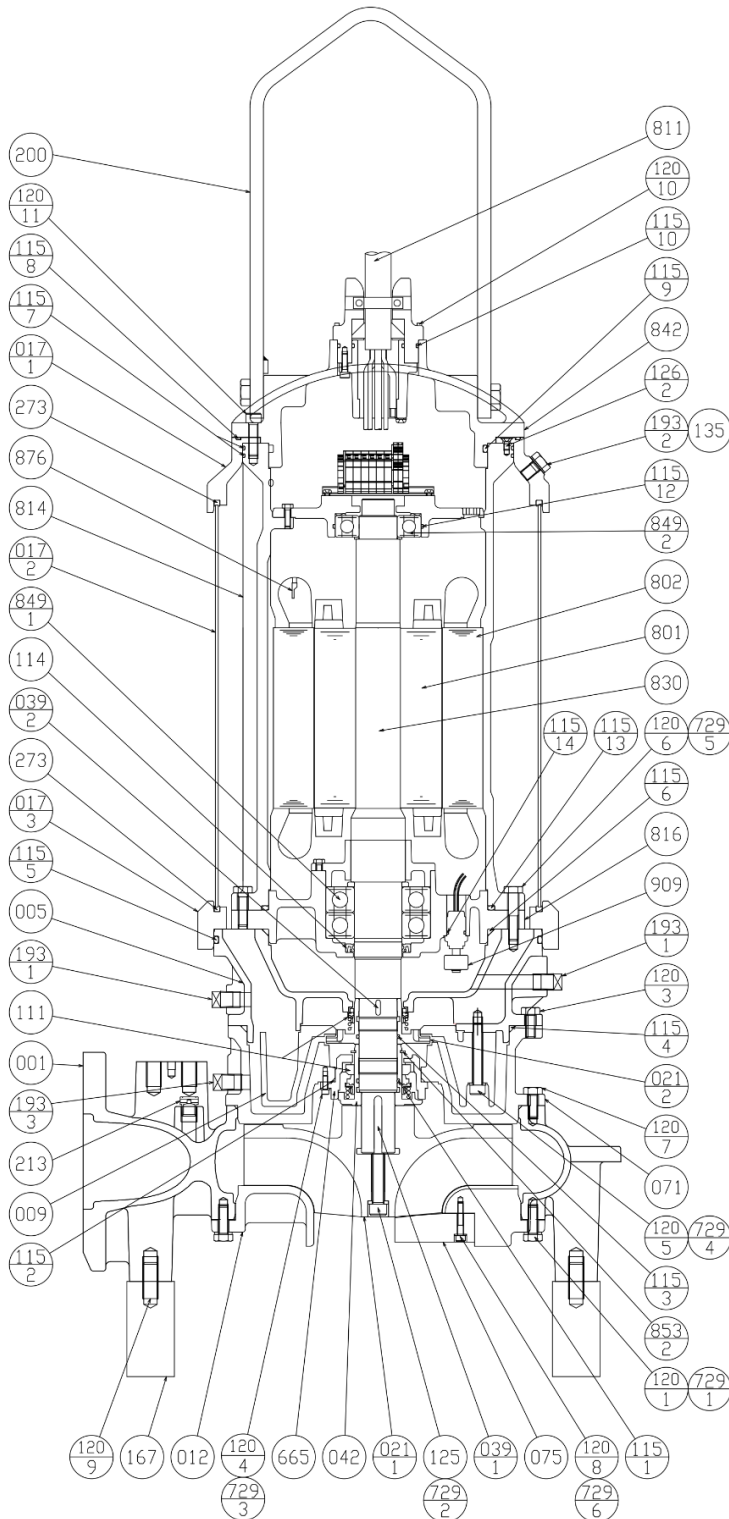

Item Number	Part Name	Material	Qty per unit
001	Pump Casing	Cast Iron(FC250) / Ductile Cast Iron (FCD400)	1
005	Intermediate Casing	Cast Iron(FC200)	1
009	Inner Casing	Cast Iron(FC200)	1
012	Suction Cover	Cast Iron(FC250)	1
017-1	Upper Cover	Cast Iron(FC250)	1
017-2	Jacket Body	Stainless Steel (SUS304)	1
017-3	Bottom Ring	Cast Iron(FC250)	1
021-1	Pump Impeller	Cast Iron(FC250) / Ductile Cast Iron (FCD400)	1
021-2	ICS Impeller	Stainless Steel (SCS13)	1
039-1	Key	Stainless Steel (SUS420)	1
039-2	Key	Stainless Steel (SUS316)	1
042	ICS Sleeve	Stainless Steel (SCS13)	1
071	Side Plate	Cast Iron(FC250)	1
075	Guide Pin	Ductile Cast Iron (FCD400)	1
111	Mechanical Seal	-	1 set
114	Oil Seal	-	1
115-1	O-Ring	NBR	1
115-2	O-Ring	NBR	1
115-3	O-Ring	NBR	1
115-4	O-Ring	NBR	1
115-5	O-Ring	NBR	1
115-6	O-Ring	NBR	1
115-7	O-Ring	NBR	2
115-8	O-Ring	NBR	1
115-9	O-Ring	NBR	1
115-10	O-Ring	NBR	1
115-12	O-Ring	NBR	1
115-13	O-Ring	NBR	1
115-14	O-Ring	NBR	1
120-1	Bolt	Stainless Steel (SUS304)	8
120-2	Bolt	Stainless Steel (SUS304)	8
120-3	Bolt	Stainless Steel (SUS304)	8
120-4	Bolt	Stainless Steel (SUS304)	4
120-5	Bolt	Stainless Steel (SUS304)	4
120-6	Bolt	Stainless Steel (SUS304)	4
120-8	Bolt	Stainless Steel (SUS304)	2
120-9	Bolt	Stainless Steel (SUS304)	3
120-10	Bolt	Stainless Steel (SUS304)	4
120-11	Bolt	Stainless Steel (SUS304)	4
125	Impeller Bolt	Stainless Steel (SUS304)	1
126-2	Countersunk Screw	Stainless Steel (SUS304)	4
135	Seal Washer	-	2
167	Pump Leg	Steel (SS400)	3
193-1	Plug	Stainless Steel (SUS304)	2
193-2	Plug	Stainless Steel (SUS304)	2
193-3	Plug	Stainless Steel (SUS304)	1
200	Lifting Hanger	Stainless Steel (SUS304)	1
213	Air Vent Valve	Brass (C3604)	1
273	Seal Packing	NBR	2
665	ICS Housing	FC200	4
729-1	Spring Washer	Stainless Steel (SUS304)	8
729-2	Spring Washer	Stainless Steel (SUS304)	1
729-3	Spring Washer	Stainless Steel (SUS304)	4
729-4	Spring Washer	Stainless Steel (SUS304)	4
729-5	Spring Washer	Stainless Steel (SUS304)	4
729-6	Spring Washer	Stainless Steel (SUS304)	2
800	Motor	-	1
811	Submersible Cable	-	1
814	Motor Frame	Cast Iron(FC200)	1
816	Power Side Braket	Cast Iron(FC200)	1
830	Shaft	Stainless Steel (SUS403)	1
842	Motor Cover	Cast Iron(FC200)	1
849-1	Ball Bearing	-	1
849-2	Ball Bearing	-	1
853-2	C-Type Snap Ring	-	1
876	Thermal Protector	-	3
909	Leakage Detector	-	1



Sectional View

View 4

100DKE(X)U 7.5, 10, and 15HP,
 150DKE(X)U 10, 15, 25, and 30HP,
 200DKE(X)U 15, 25, and 30HP,
 250DKE(X)U 25 and 30HP.

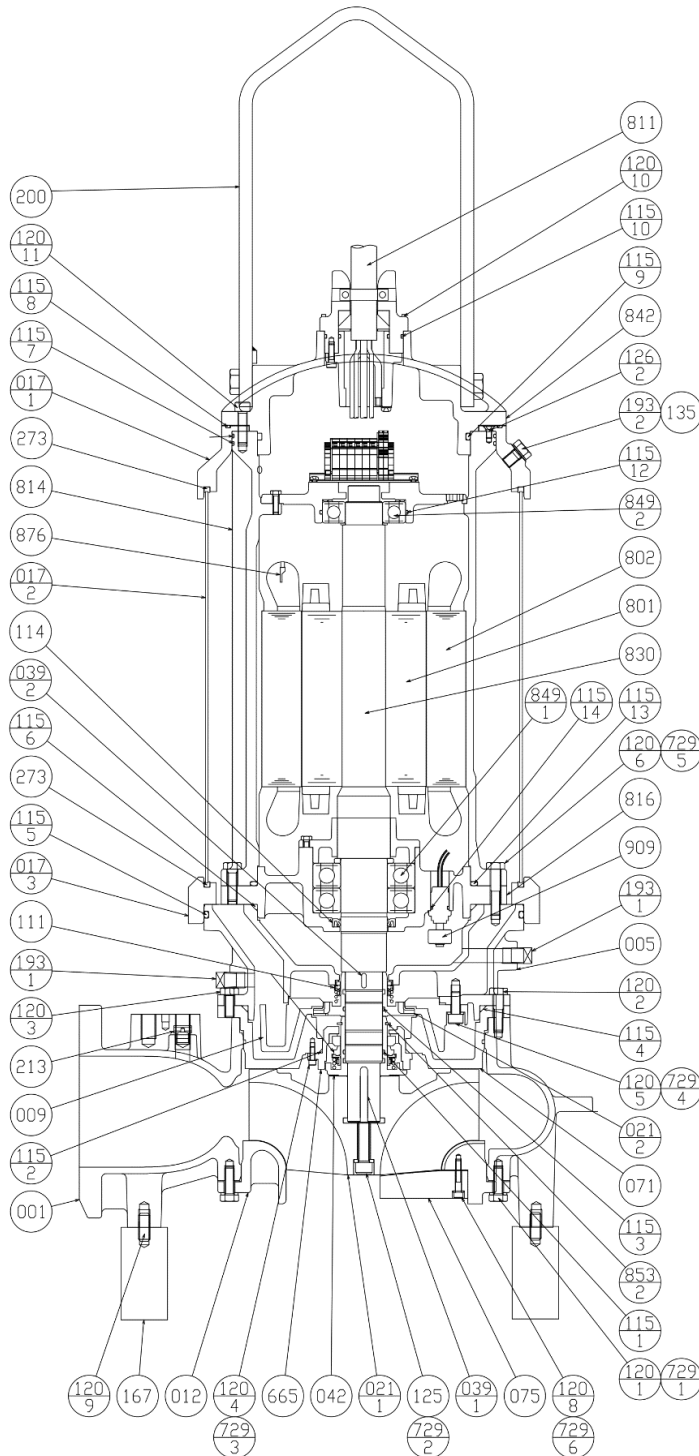

Item Number	Part Name	Material	Qty per unit
001	Pump Casing	Cast Iron(FC250) / Ductile Cast Iron (FCD400)	1
005	Intermediate Casing	Cast Iron(FC200)	1
009	Inner Casing	Cast Iron(FC200)	1
012	Suction Cover	Cast Iron(FC250)	1
017-1	Upper Cover	Cast Iron(FC250)	1
017-2	Jacket Body	Stainless Steel (SUS304)	1
017-3	Bottom Ring	Cast Iron(FC250)	1
021-1	Pump Impeller	Cast Iron(FC250) / Ductile Cast Iron (FCD400)	1
021-2	ICS Impeller	Stainless Steel (SCS13)	1
039-1	Key	Stainless Steel (SUS420)	1
039-2	Key	Stainless Steel (SUS316)	1
042	ICS Sleeve	Stainless Steel (SCS13)	1
071	Side Plate	Cast Iron(FC250)	1
075	Guide Pin	Ductile Cast Iron (FCD400)	1
111	Mechanical Seal	-	1 set
114	Oil Seal	-	1
115-1	O-Ring	NBR	1
115-2	O-Ring	NBR	1
115-3	O-Ring	NBR	1
115-4	O-Ring	NBR	1
115-5	O-Ring	NBR	1
115-6	O-Ring	NBR	1
115-7	O-Ring	NBR	2
115-8	O-Ring	NBR	1
115-9	O-Ring	NBR	1
115-10	O-Ring	NBR	1
115-12	O-Ring	NBR	1
115-13	O-Ring	NBR	1
115-14	O-Ring	NBR	1
120-1	Bolt	Stainless Steel (SUS304)	8
120-2	Bolt	Stainless Steel (SUS304)	8
120-3	Bolt	Stainless Steel (SUS304)	4
120-4	Bolt	Stainless Steel (SUS304)	4
120-5	Bolt	Stainless Steel (SUS304)	4
120-6	Bolt	Stainless Steel (SUS304)	4
120-8	Bolt	Stainless Steel (SUS304)	2
120-9	Bolt	Stainless Steel (SUS304)	3
120-10	Bolt	Stainless Steel (SUS304)	4
120-11	Bolt	Stainless Steel (SUS304)	4
125	Impeller Bolt	Stainless Steel (SUS304)	1
126-2	Countersunk Screw	Stainless Steel (SUS304)	4
135	Seal Washer	-	2
167	Pump Leg	Steel (SS400)	3
193-1	Plug	Stainless Steel (SUS304)	2
193-2	Plug	Stainless Steel (SUS304)	2
200	Lifting Hanger	Stainless Steel (SUS304)	1
213	Air Vent Valve	Brass (C3604)	1
273	Seal Packing	NBR	2
665	ICS Housing	FC200	1
729-1	Spring Washer	Stainless Steel (SUS304)	8
729-2	Spring Washer	Stainless Steel (SUS304)	1
729-3	Spring Washer	Stainless Steel (SUS304)	4
729-4	Spring Washer	Stainless Steel (SUS304)	4
729-5	Spring Washer	Stainless Steel (SUS304)	4
729-6	Spring Washer	Stainless Steel (SUS304)	2
800	Motor	-	1
811	Submersible Cable	-	1
814	Motor Frame	Cast Iron(FC200)	1
816	Power Side Braket	Cast Iron(FC200)	1
830	Shaft	Stainless Steel (SUS403)	1
842	Motor Cover	Cast Iron(FC200)	1
849-1	Ball Bearing	-	1
849-2	Ball Bearing	-	1
853-2	C-Type Snap Ring	-	1
876	Thermal Protector	-	3
909	Leakage Detector	-	1



Sectional View

View 6

100DKEB(X)U 20HP.

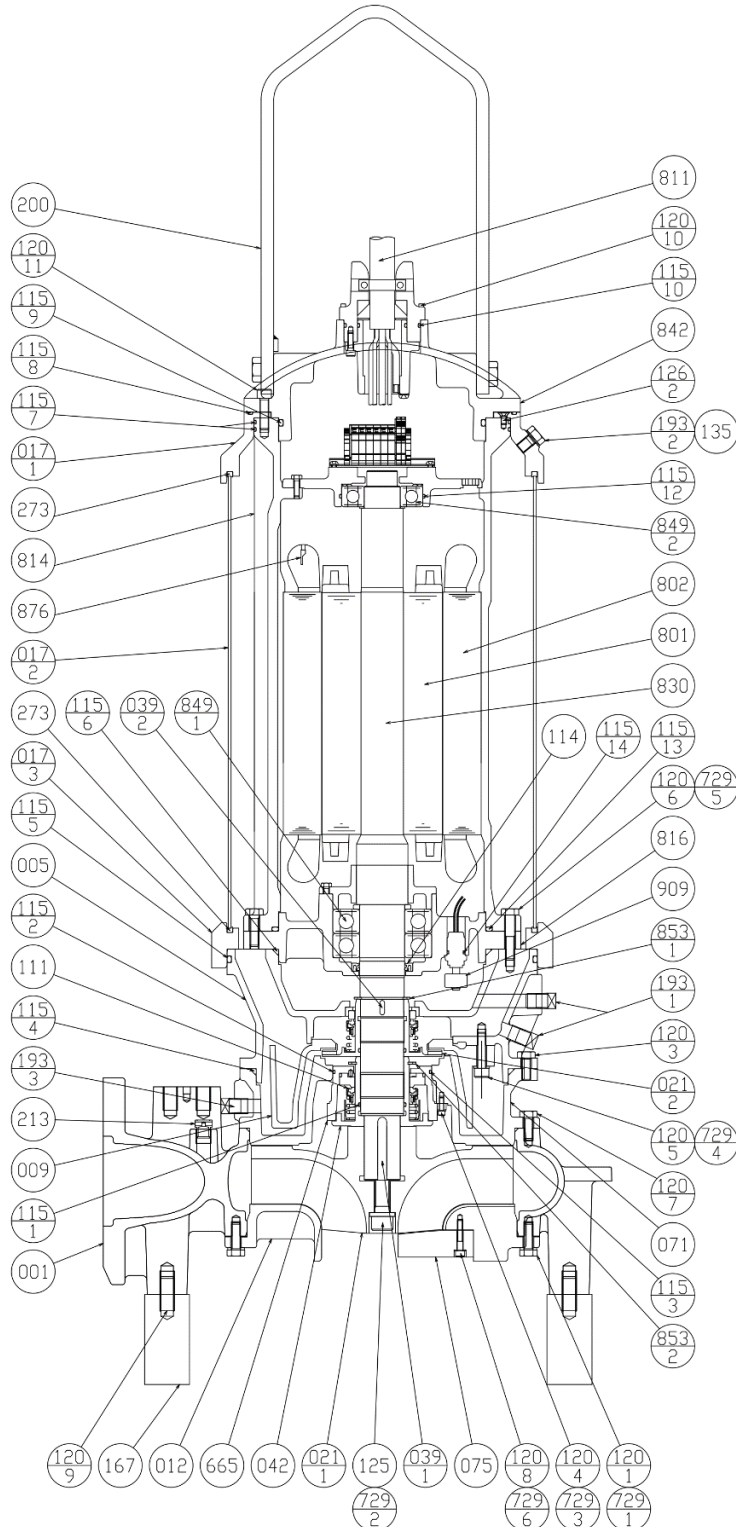

Item Number	Part Name	Material	Qty per unit
001	Pump Casing	Ductile Cast Iron (FCD400)	1
005	Intermediate Casing	Cast Iron(FC200)	1
009	Inner Casing	Cast Iron(FC200)	1
012	Suction Cover	Cast Iron(FC250)	1
017-1	Upper Cover	Cast Iron(FC250)	1
017-2	Jacket Body	Stainless Steel (SUS304)	1
017-3	Bottom Ring	Cast Iron(FC250)	1
021-1	Pump Impeller	Ductile Cast Iron (FCD400)	1
021-2	ICS Impeller	Stainless Steel (SCS13)	1
039-1	Key	Stainless Steel (SUS420)	1
039-2	Key	Stainless Steel (SUS316)	1
042	ICS Sleeve	Stainless Steel (SCS13)	1
071	Side Plate	Cast Iron(FC250)	1
075	Guide Pin	Ductile Cast Iron (FCD400)	1
111	Mechanical Seal	-	1 Set
114	Oil Seal	-	1
115-1	O-Ring	NBR	1
115-2	O-Ring	NBR	1
115-3	O-Ring	NBR	1
115-4	O-Ring	NBR	1
115-5	O-Ring	NBR	1
115-6	O-Ring	NBR	1
115-7	O-Ring	NBR	2
115-8	O-Ring	NBR	1
115-9	O-Ring	NBR	1
115-10	O-Ring	NBR	1
115-12	O-Ring	NBR	1
115-13	O-Ring	NBR	1
115-14	O-Ring	NBR	1
120-1	Bolt	Stainless Steel (SUS304)	8
120-3	Bolt	Stainless Steel (SUS304)	8
120-4	Bolt	Stainless Steel (SUS304)	4
120-5	Bolt	Stainless Steel (SUS304)	4
120-6	Bolt	Stainless Steel (SUS304)	4
120-7	Bolt	Stainless Steel (SUS304)	8
120-8	Bolt	Stainless Steel (SUS304)	2
120-9	Bolt	Stainless Steel (SUS304)	3
120-10	Bolt	Stainless Steel (SUS304)	4
120-11	Bolt	Stainless Steel (SUS304)	4
125	Impeller Bolt	Stainless Steel (SUS304)	1
126-2	Countersunk Screw	Stainless Steel (SUS304)	4
135	Seal Washer	-	2
167	Pump Leg	Steel (SS400)	3
193-1	Plug	Stainless Steel (SUS304)	2
193-2	Plug	Stainless Steel (SUS304)	2
193-3	Plug	Stainless Steel (SUS304)	1
200	Lifting Hanger	Stainless Steel (SUS304)	1
213	Air Vent Valve	Brass (C3604)	1
273	Seal Packing	NBR	2
665	ICS Housing	FC200	1
729-1	Spring Washer	Stainless Steel (SUS304)	8
729-2	Spring Washer	Stainless Steel (SUS304)	1
729-3	Spring Washer	Stainless Steel (SUS304)	4
729-4	Spring Washer	Stainless Steel (SUS304)	4
729-5	Spring Washer	Stainless Steel (SUS304)	4
729-6	Spring Washer	Stainless Steel (SUS304)	2
800	Motor	-	1
811	Submersible Cable	-	1
814	Motor Frame	Cast Iron(FC200)	1
816	Power Side Braket	Cast Iron(FC200)	1
830	Shaft	Stainless Steel (SUS403)	1
842	Motor Cover	Cast Iron(FC200)	1
849-1	Ball Bearing	-	1
849-2	Ball Bearing	-	1
853-1	C-Type Snap Ring	-	1
853-2	C-Type Snap Ring	-	1
876	Thermal Protector	-	3
909	Leakage Detector	-	1



EBARA PUMPS AMERICAS CORPORATION

www.pumpsebara.com

(t) 803.327.5005 (f) 803.327.5097

Sectional View

View 7

100DKE(X)U 40 to 60HP.

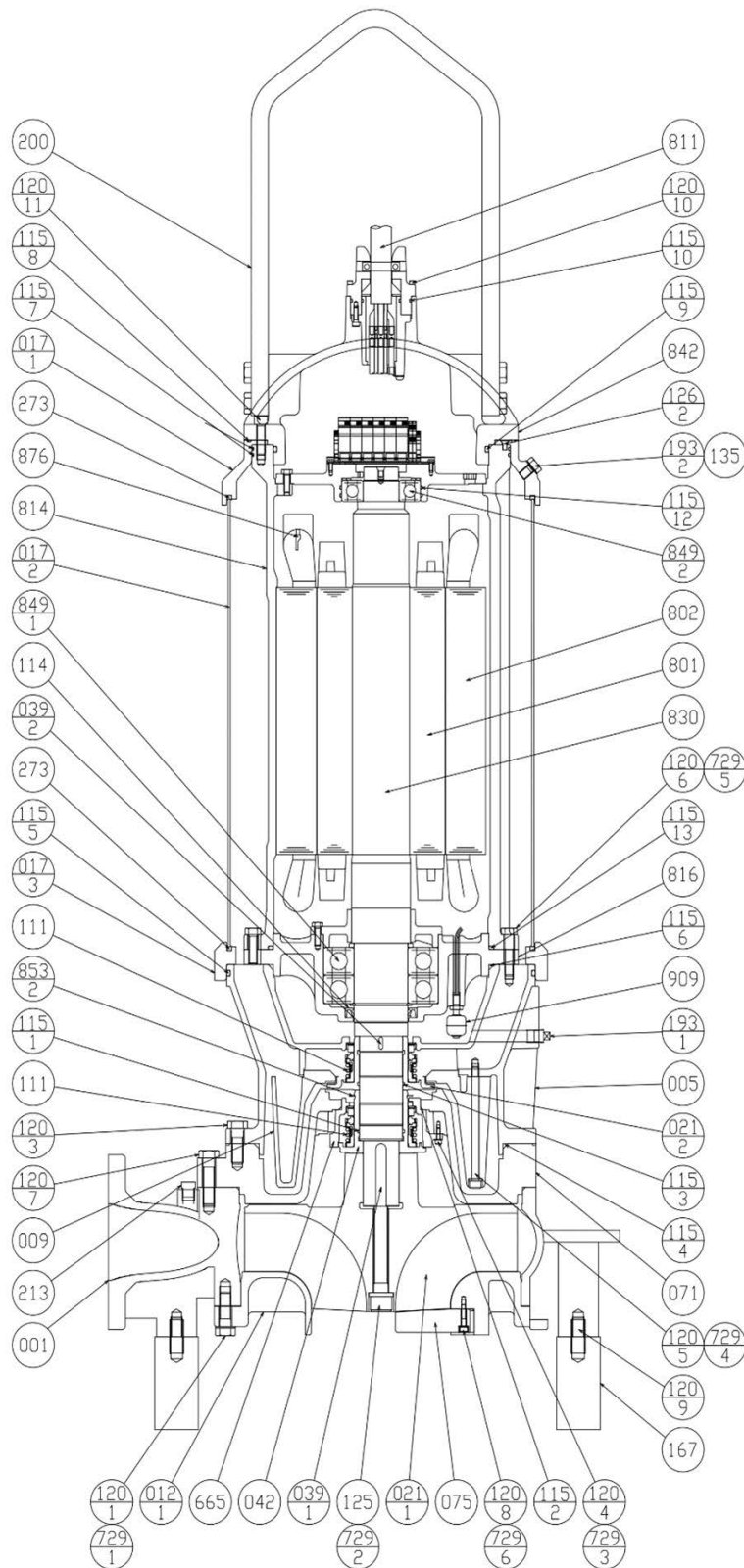

Item Number	Part Name	Material	Qty per unit
001	Pump Casing	Cast Iron(FC250)	1
005	Intermediate Casing	Cast Iron(FC200)	1
009	Inner Casing	Cast Iron(FC200)	1
012-1	Suction Cover	Cast Iron(FC250)	1
017-1	Upper Cover	Cast Iron(FC250)	1
017-2	Jacket Body	Stainless Steel (SUS304)	1
017-3	Bottom Ring	Cast Iron(FC250)	1
021-1	Pump Impeller	Ductile Cast Iron (FCD500)	1
021-2	ICS Impeller	Stainless Steel (SCS13)	1
039-1	Key	Stainless Steel (SUS420)	1
039-2	Key	Stainless Steel (SUS316)	1
042	ICS Sleeve	Stainless Steel (SCS13)	1
071	Side Plate	Cast Iron(FC250)	1
075	Guide Pin	Ductile Cast Iron (FCD400)	1
111	Mechanical Seal	-	1 Set
114	Oil Seal	-	1
115-1	O-Ring	NBR	1
115-2	O-Ring	NBR	1
115-3	O-Ring	NBR	1
115-4	O-Ring	NBR	1
115-5	O-Ring	NBR	1
115-6	O-Ring	NBR	1
115-7	O-Ring	NBR	2
115-8	O-Ring	NBR	1
115-9	O-Ring	NBR	1
115-10	O-Ring	NBR	1
115-12	O-Ring	NBR	1
115-13	O-Ring	NBR	1
120-1	Bolt	Stainless Steel (SUS304)	8
120-3	Bolt	Stainless Steel (SUS304)	8
120-4	Bolt	Stainless Steel (SUS304)	4
120-5	Bolt	Stainless Steel (SUS304)	4
120-6	Bolt	Stainless Steel (SUS304)	4
120-7	Bolt	Stainless Steel (SUS304)	8
120-8	Bolt	Stainless Steel (SUS304)	2
120-9	Bolt	Stainless Steel (SUS304)	3
120-10	Bolt	Stainless Steel (SUS304)	4
120-11	Bolt	Stainless Steel (SUS304)	8
125	Impeller Bolt	Stainless Steel (SUS304)	1
126-2	Countersunk Screw	Stainless Steel (SUS304)	4
135	Seal Washer	-	2
167	Pump Leg	Steel (SS400)	3
193-1	Plug	Stainless Steel (SUS304)	2
193-2	Plug	Stainless Steel (SUS304)	2
200	Lifting Hanger	Stainless Steel (SUS304)	1
213	Air Vent Valve	Brass (C3604)	1
273	Seal Packing	NBR	2
665	ICS Housing	FC200	1
729-1	Spring Washer	Stainless Steel (SUS304)	8
729-2	Spring Washer	Stainless Steel (SUS304)	1
729-3	Spring Washer	Stainless Steel (SUS304)	4
729-4	Spring Washer	Stainless Steel (SUS304)	4
729-5	Spring Washer	Stainless Steel (SUS304)	4
729-6	Spring Washer	Stainless Steel (SUS304)	2
800	Motor	-	1
811	Submersible Cable	-	1
814	Motor Frame	Cast Iron(FC200)	1
816	Power Side Bracket	Cast Iron(FC200)	1
830	Shaft	Stainless Steel (SUS403)	1
842	Motor Cover	Cast Iron(FC200)	1
849-1	Ball Bearing	-	1
849-2	Ball Bearing	-	1
853-2	C-Type Snap Ring	-	1
876	Thermal Protector	-	3
909	Leakage Detector	-	1



Sectional View

View 8

150DKE(X)U / DKEB(X)U 40 to 60HP,
 200DKE(X)U 40 to 60HP,
 250DKE(X)U 40 to 60HP.

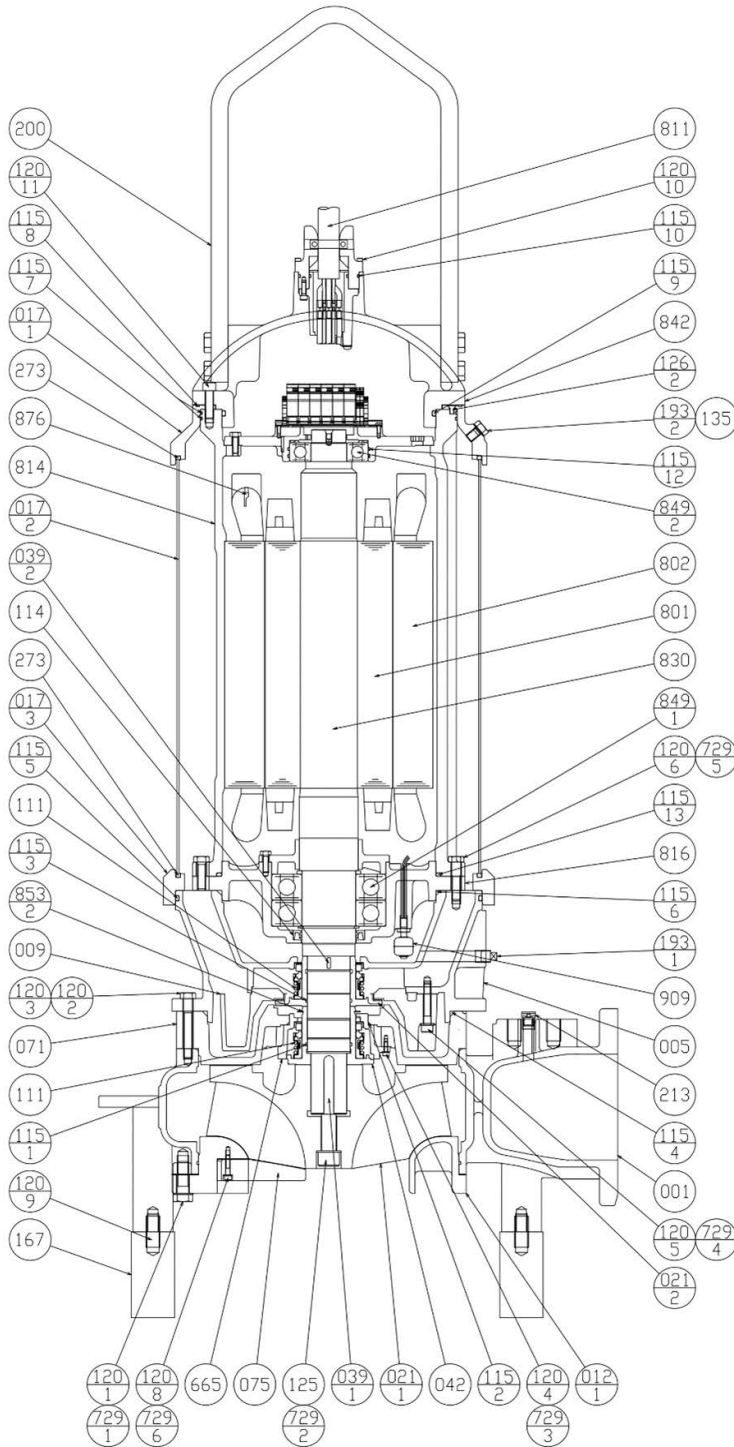

Item Number	Part Name	Material	Qty per unit
001	Pump Casing	Ductile Cast Iron (FCD400)	1
005	Intermediate Casing	Cast Iron(FC200)	1
009	Inner Casing	Cast Iron(FC200)	1
012-1	Suction Cover	Cast Iron(FC250)	1
017-1	Upper Cover	Cast Iron(FC250)	1
017-2	Jacket Body	Stainless Steel (SUS304)	1
017-3	Bottom Ring	Cast Iron(FC250)	1
021-1	Pump Impeller	Ductile Cast Iron (FCD400)	1
021-2	ICS Impeller	Stainless Steel (SCS13)	1
039-1	Key	Stainless Steel (SUS420)	1
039-2	Key	Stainless Steel (SUS316)	1
042	ICS Sleeve	Stainless Steel (SCS13)	1
071	Side Plate	Cast Iron(FC250)	1
075	Guide Pin	Ductile Cast Iron (FCD400)	1
111	Mechanical Seal	-	1 Set
114	Oil Seal	-	1
115-1	O-Ring	NBR	1
115-2	O-Ring	NBR	1
115-3	O-Ring	NBR	1
115-4	O-Ring	NBR	1
115-5	O-Ring	NBR	1
115-6	O-Ring	NBR	1
115-7	O-Ring	NBR	2
115-8	O-Ring	NBR	1
115-9	O-Ring	NBR	1
115-10	O-Ring	NBR	1
115-12	O-Ring	NBR	2
115-13	O-Ring	NBR	1
120-1	Bolt	Stainless Steel (SUS304)	8
120-2	Bolt	Stainless Steel (SUS304)	8
120-3	Bolt	Stainless Steel (SUS304)	4
120-4	Bolt	Stainless Steel (SUS304)	4
120-5	Bolt	Stainless Steel (SUS304)	4
120-6	Bolt	Stainless Steel (SUS304)	8
120-8	Bolt	Stainless Steel (SUS304)	2
120-9	Bolt	Stainless Steel (SUS304)	3
120-10	Bolt	Stainless Steel (SUS304)	4
120-11	Bolt	Stainless Steel (SUS304)	8
125	Impeller Bolt	Stainless Steel (SUS304)	1
126-2	Countersunk Screw	Stainless Steel (SUS304)	4
135	Seal Washer	-	2
167	Pump Leg	Steel (SS400)	3
193-1	Plug	Stainless Steel (SUS304)	2
193-2	Plug	Stainless Steel (SUS304)	2
200	Lifting Hanger	Stainless Steel (SUS304)	1
213	Air Vent Valve	Brass (C3604)	1
273	Seal Packing	NBR	2
665	ICS Housing	FC200	1
729-1	Spring Washer	Stainless Steel (SUS304)	8
729-2	Spring Washer	Stainless Steel (SUS304)	1
729-3	Spring Washer	Stainless Steel (SUS304)	4
729-4	Spring Washer	Stainless Steel (SUS304)	4
729-5	Spring Washer	Stainless Steel (SUS304)	4
729-6	Spring Washer	Stainless Steel (SUS304)	2
800	Motor	-	1
811	Submersible Cable	-	1
814	Motor Frame	Cast Iron(FC200)	1
816	Power Side Braket	Cast Iron(FC200)	1
830	Shaft	Stainless Steel (SUS403)	1
842	Motor Cover	Cast Iron(FC200)	1
849-1	Ball Bearing	-	1
849-2	Ball Bearing	-	1
853-2	C-Type Snap Ring	-	1
876	Thermal Protector	-	3
909	Leakage Detector	-	1

