

**Contents**

---

**Model**

LS50  
LM50  
LM65  
LM80  
LL100

---

<b>Section</b>	<b>Page</b>
Specifications	1-190
Outline Drawings	1-191
Sectional View	1-194

---



---

**Specifications**

---

Project:

Model:

Chk'd:

Date:

---

**Quick Discharge Connector  
DSU, DSHU, DVSU, DVSHU****A. General:**

The guide rail system design shall be such that the pump will be automatically connected to the discharge piping when lowered into place on the discharge connection. The pump shall be easily removable for inspection or service, requiring no bolts, nuts, or other fasteners to be disconnected, or the need for personnel to enter the wet well.

**B. Guide Rail system:**

Design shall include two (2) 304SS schedule 40 guide rails that are sized to mount directly to the quick discharge connector, QDC, at the floor of the wetwell and to a guide rail bracket at the top of the wetwell below the hatch opening, (refer to project drawings).

Intermediate guide brackets are recommended for rail lengths over 20 feet. Guide rails are not part of the pump package and shall be supplied by others.

The QDC shall be manufactured of cast iron, ASTM A48 Class 30. It shall be designed to adequately support the guide rails, discharge piping, and pumping unit under both static and dynamic loading conditions with support legs that are suitable for anchoring it to the wetwell floor.

The face of the inlet QDC flange shall be perpendicular to the floor of the wetwell.

The pump design shall include an integral self-aligning sliding bracket.

Sealing of the pumping unit to the QDC shall be accomplished by a single, linear, downward motion of the pump.

The entire weight of the pump unit shall be guided to and wedged tightly against the inlet flange of the QDC, making metal to metal contact with the pump discharge forming a seal without the use of bolts, gaskets or O-rings.

A stainless steel lifting chain of adequate length for removing and installing the pump unit is recommended. The chain shall have a round link with a 2-<sup>1</sup>/<sub>4</sub>" inside diameter every two feet. This link will allow for a sliding pinch bar through the link to pick the chain, more than once if necessary, at multiple intervals during pump removal and installation.



**Dimensions**

Project: \_\_\_\_\_ Model: \_\_\_\_\_ Chk'd: \_\_\_\_\_ Date: \_\_\_\_\_

**Model LS50**

50DSHU 1/2 to 2HP

50DVSHU 1/2 to 2HP

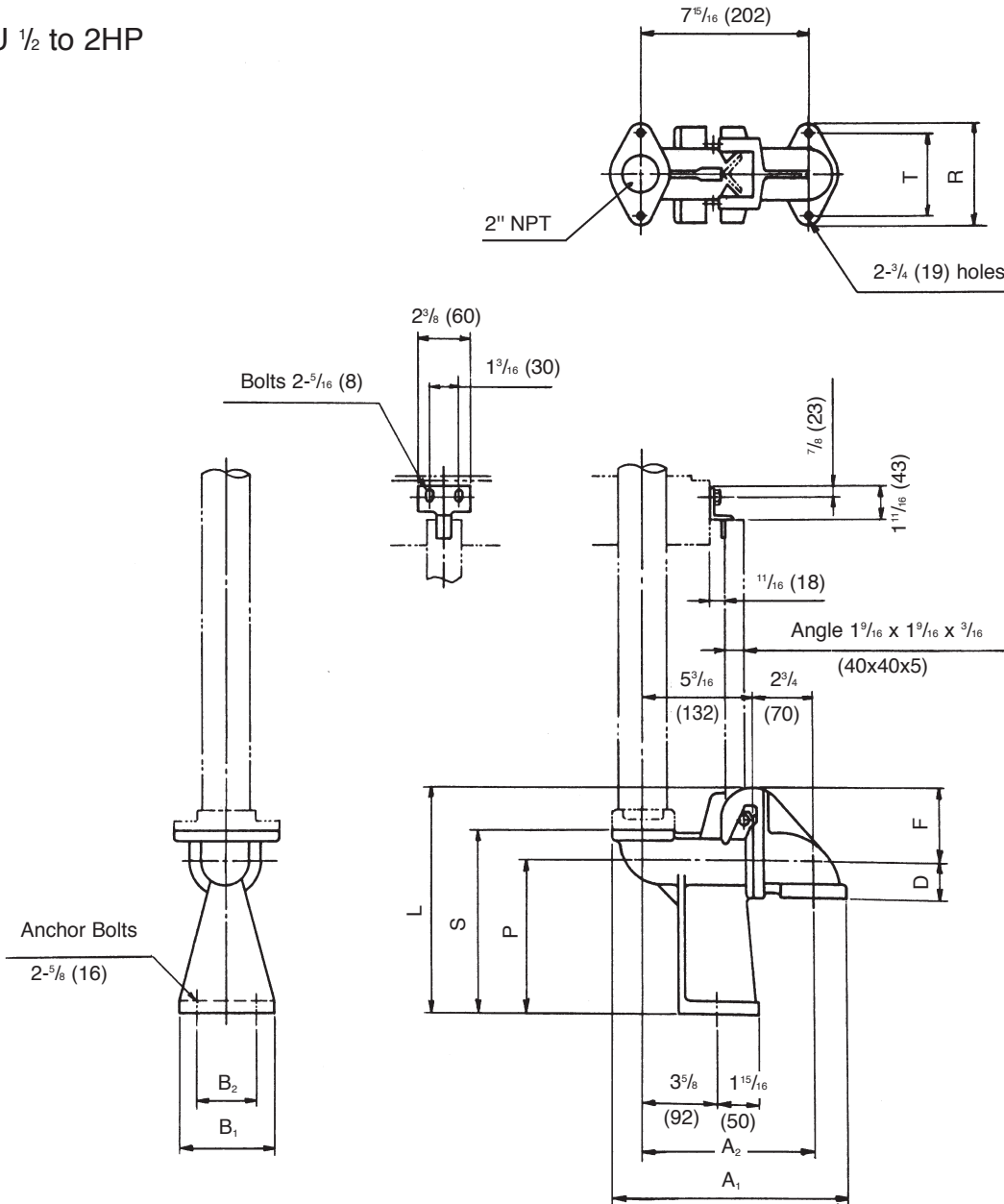

**Dimensions: inch**

MODEL	A <sub>1</sub>	A <sub>2</sub>	B <sub>1</sub>	B <sub>2</sub>	D	F	L	R	T	S	P	WEIGHT (Lb)
LS50	10 <sup>15</sup> / <sub>16</sub>	7 <sup>15</sup> / <sub>16</sub>	4 <sup>1</sup> / <sub>2</sub>	2 <sup>3</sup> / <sub>4</sub>	1 <sup>9</sup> / <sub>16</sub>	3 <sup>1</sup> / <sub>4</sub>	10 <sup>3</sup> / <sub>8</sub>	4 <sup>13</sup> / <sub>16</sub>	3 <sup>3</sup> / <sub>4</sub>	8 <sup>7</sup> / <sub>16</sub>	7 <sup>1</sup> / <sub>16</sub>	20

**Dimensions: mm**

MODEL	A <sub>1</sub>	A <sub>2</sub>	B <sub>1</sub>	B <sub>2</sub>	D	F	L	R	T	S	P	WEIGHT (kg)
LS50	278	202	114	70	40	83	263	122	96	215	180	9

**Dimensions**

Project: \_\_\_\_\_ Model: \_\_\_\_\_ Chk'd: \_\_\_\_\_ Date: \_\_\_\_\_

**Models LM50, LM65, LM80**

50DSU, DSHU 3 to 5HP

80DVSU, DVSHU 1 to 5HP

80DSU, DSHU 3 to 5HP

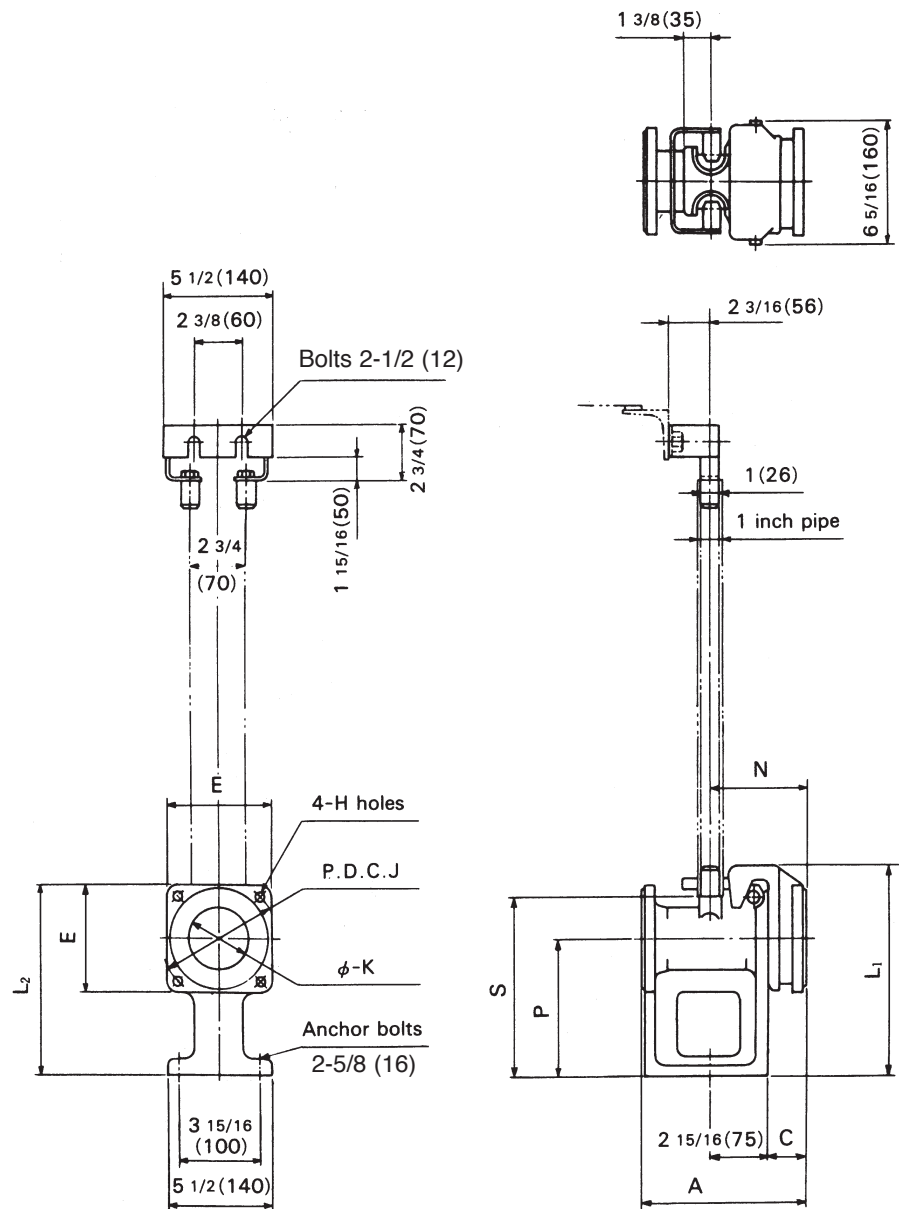

**Dimensions: inch**

MODEL	A	C	E	H	J	K	L <sub>1</sub>	L <sub>2</sub>	N	P	S	WEIGHT Lb
LM50	7 <sup>11</sup> / <sub>16</sub>	1 <sup>9</sup> / <sub>16</sub>	4 <sup>5</sup> / <sub>16</sub>	1/2	4 <sup>3</sup> / <sub>4</sub>	2	8 <sup>1</sup> / <sub>4</sub>	7 <sup>1</sup> / <sub>2</sub>	4 <sup>1</sup> / <sub>2</sub>	5 <sup>5</sup> / <sub>16</sub>	6 <sup>1</sup> / <sub>2</sub>	24
LM65	8 <sup>7</sup> / <sub>16</sub>	1 <sup>3</sup> / <sub>4</sub>	5 <sup>1</sup> / <sub>8</sub>	1/2	5 <sup>1</sup> / <sub>2</sub>	2 <sup>1</sup> / <sub>2</sub>	9 <sup>1</sup> / <sub>16</sub>	8 <sup>1</sup> / <sub>4</sub>	4 <sup>3</sup> / <sub>4</sub>	5 <sup>11</sup> / <sub>16</sub>	7 <sup>1</sup> / <sub>2</sub>	31
LM80	8 <sup>7</sup> / <sub>16</sub>	1 <sup>15</sup> / <sub>16</sub>	5 <sup>1</sup> / <sub>2</sub>	9/16	6 <sup>1</sup> / <sub>8</sub>	3	10 <sup>5</sup> / <sub>16</sub>	9 <sup>5</sup> / <sub>8</sub>	4 <sup>15</sup> / <sub>16</sub>	6 <sup>3</sup> / <sub>8</sub>	9 <sup>1</sup> / <sub>16</sub>	37

**Dimensions: mm**

MODEL	A	C	E	H	J	K	L <sub>1</sub>	L <sub>2</sub>	N	P	S	WEIGHT kg
LM50	195	40	110	12	120	50	210	190	115	135	165	11
LM65	215	45	130	12	140	65	230	210	120	145	190	14
LM80	215	50	140	15	155	80	270	245	125	175	230	17

**Dimensions**

Project: \_\_\_\_\_ Model: \_\_\_\_\_ Chk'd: \_\_\_\_\_ Date: \_\_\_\_\_

**Models LL100**

100DSU, 7 1/2 to 10 HP

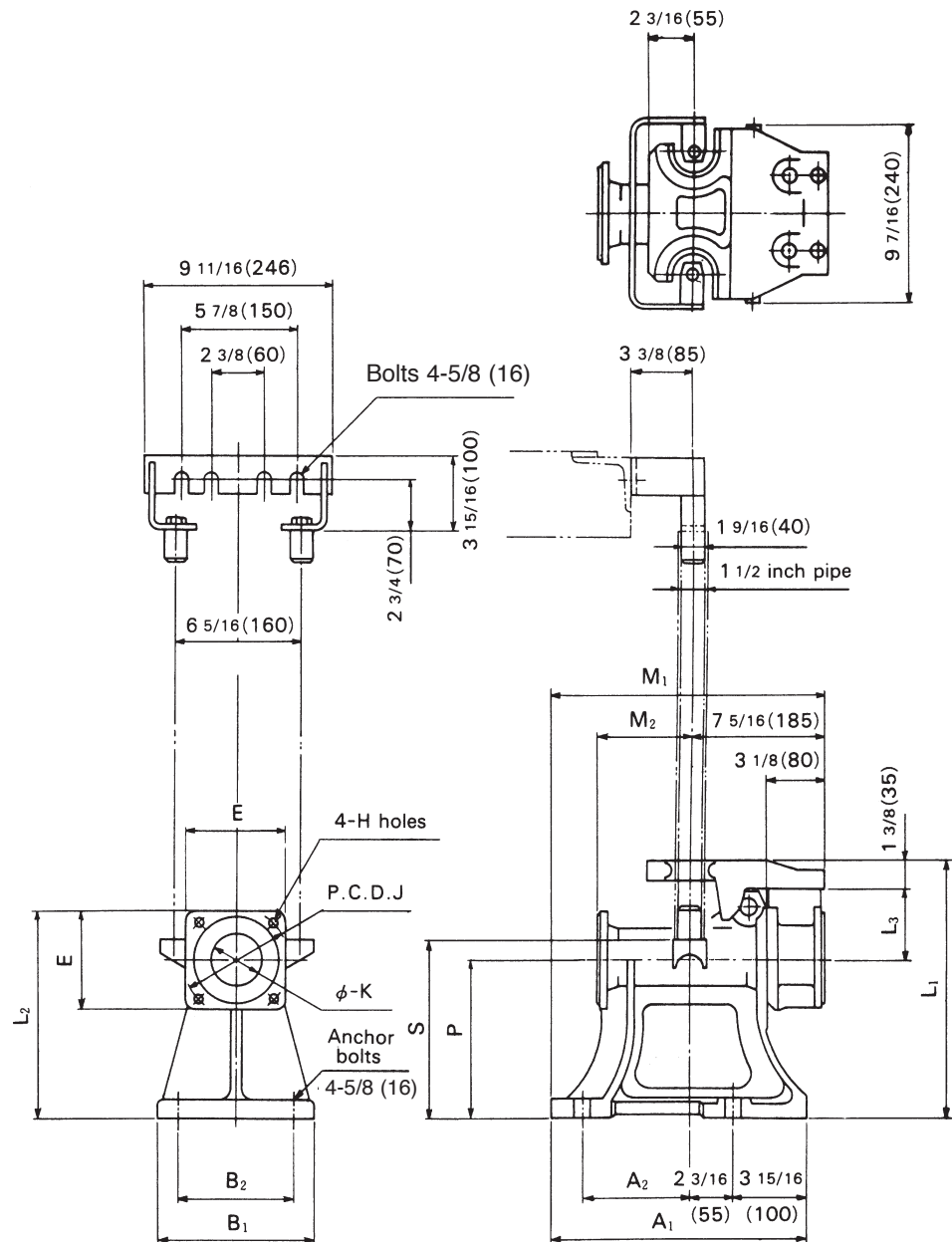

**Dimensions: inch**

MODEL	A <sub>1</sub>	A <sub>2</sub>	B <sub>1</sub>	B <sub>2</sub>	E	H	J	K	L <sub>1</sub>	L <sub>2</sub>	L <sub>3</sub>	M <sub>1</sub>	M <sub>2</sub>	P	S	WEIGHT Lb
LL100	14 <sup>3</sup> / <sub>16</sub>	6 <sup>1</sup> / <sub>2</sub>	9 <sup>1</sup> / <sub>16</sub>	7 <sup>1</sup> / <sub>16</sub>	6 <sup>5</sup> / <sub>16</sub>	<sup>3</sup> / <sub>4</sub>	6 <sup>7</sup> / <sub>8</sub>	4	14 <sup>15</sup> / <sub>16</sub>	12 <sup>2</sup> / <sub>8</sub>	4 <sup>1</sup> / <sub>8</sub>	15 <sup>3</sup> / <sub>8</sub>	4 <sup>1</sup> / <sub>8</sub>	9 <sup>7</sup> / <sub>16</sub>	10 <sup>7</sup> / <sub>16</sub>	101

**Dimensions: mm**

MODEL	A <sub>1</sub>	A <sub>2</sub>	B <sub>1</sub>	B <sub>2</sub>	E	H	J	K	L <sub>1</sub>	L <sub>2</sub>	L <sub>3</sub>	M <sub>1</sub>	M <sub>2</sub>	P	S	WEIGHT kg
LL100	360	165	230	180	160	19	175	100	380	320	105	390	105	240	265	46

**Sectional View**

Project: \_\_\_\_\_ Model: \_\_\_\_\_ Chk'd: \_\_\_\_\_ Date: \_\_\_\_\_

**Model LS50**

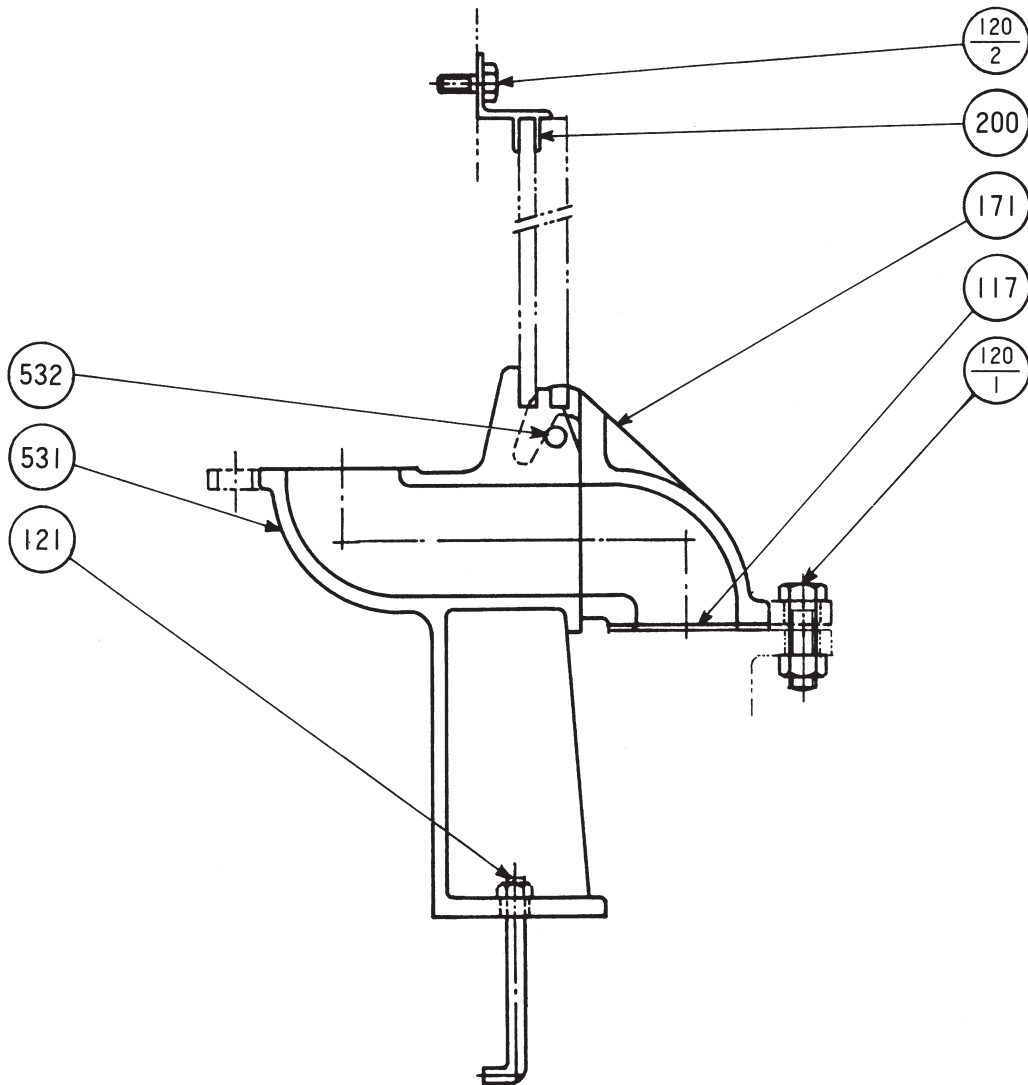

Part No.	Part Name	Material	ASTM, AISI Code	No. for 1 Unit
117	Gasket	Rubber (NBR)		1
120-1	Bolt & Nut	Steel	A283 Grade D	2
120-2	Bolt	Steel	A283 Grade D	2
121	Anchor Bolt	Steel	A283 Grade D	2
171	Connector	Cast Iron	A48 Class 30	1
200	Guide Support	Steel	A 283 Grade D	1
531	Body	Cast Iron	A48 Class 30	1
532	Support Bar	420 Stainless	AISI 420	1



**Sectional View**

Project: \_\_\_\_\_ Model: \_\_\_\_\_ Chk'd: \_\_\_\_\_ Date: \_\_\_\_\_

**Models LM50, LM65, LM80**

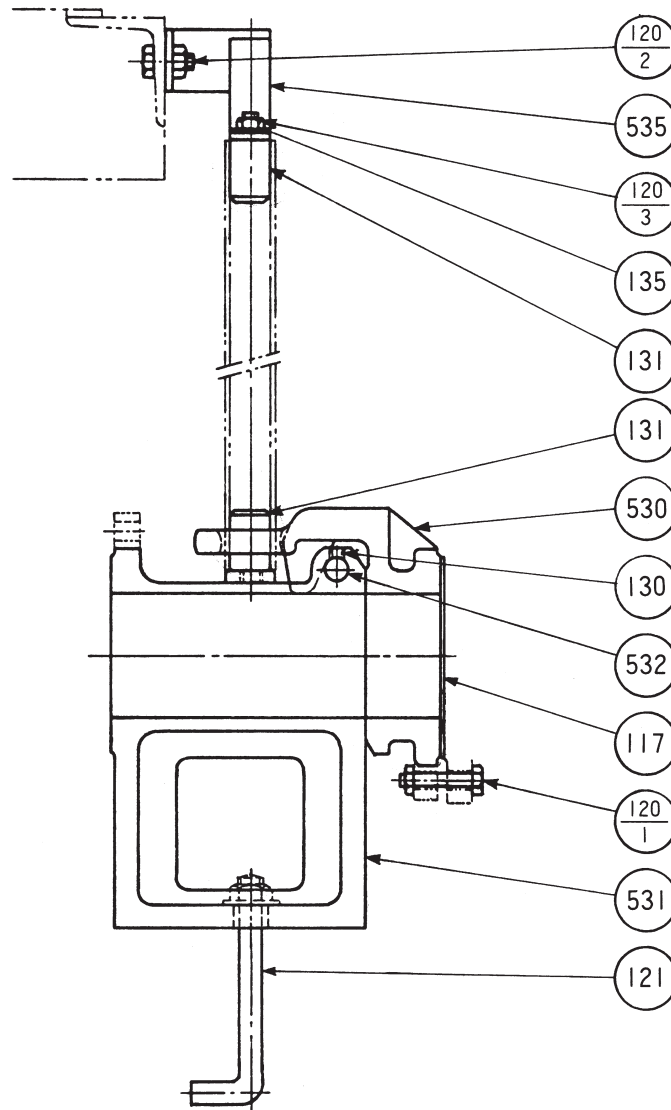

Part No.	Part Name	Material		ASTM, AISI, CODE		No. for 1 Unit
		Model LM	Model LME	Model LM	Model LME	
117	Gasket					1
120-1	Bolt & Nut	304 Stainless		AISI304		4
120-2	Bolt & Nut	304 Stainless		AISI304		2
120-3	Nut	304 Stainless		AISI304		2
121	Anchor Bolt	Steel		A283 Grade D		2
130	Set Screw	304 Stainless		AISI304		1
131	Guide Pin	Steel	Brass	A283 Grade D	B36 C27200	4
135	Washer	304 Stainless		AISI403		2
530	Connector	Cast Iron	Bronze	A48 Class 30	B584 C83600	1
531	Body	Cast Iron		A48 Class 30		1
532	Support Bar	420 Stainless		AISI420		1
535	Guide Support Plate	Steel		A283 Grade D		1

**Sectional View**

Project: \_\_\_\_\_ Model: \_\_\_\_\_ Chk'd: \_\_\_\_\_ Date: \_\_\_\_\_

**Models LL100**

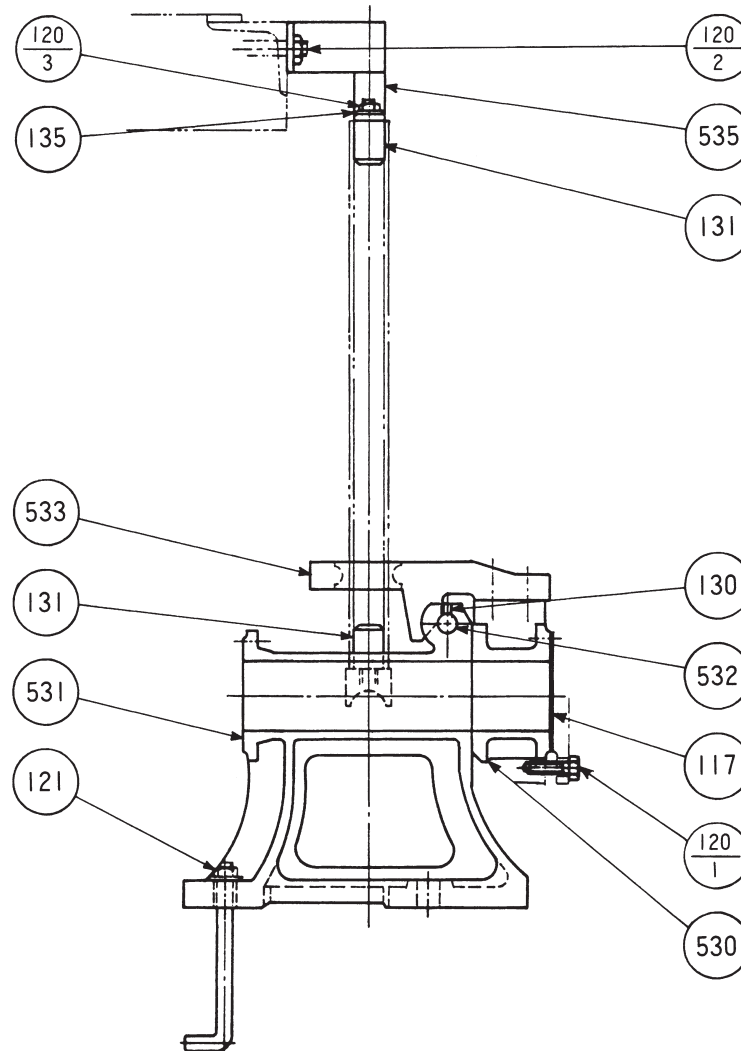

Part No.	Part Name	Material		ASTM, AISI, CODE		No. for 1 Unit
		Model LL	Model LLE	Model LL	Model LLE	
117	Gasket					1
120-1	Bolt	304 Stainless		AISI304		4
120-2	Nut	304 Stainless		AISI304		2
120-3	Nut	304 Stainless		AISI304		2
121	Anchor Bolt	Steel		A283 Grade D		4
130	Set Screw	304 Stainless		AISI304		1
131	Guide Pin	Steel	Brass	A283 Grade D	B36 C27200	4
135	Washer	304 Stainless		AISI304		2
530	Connector	Cast Iron	Bronze	A48 Class 30	B584 C83600	1
531	Body	Cast Iron		A48 Class 30		1
532	Support Bar	420 Stainless		AISI420		1
533	Sliding Guide	Cast Iron	Bronze	A48 Class 30	B584 C83600	1
535	Guide Support Plate	Steel		A283 Grade D		1