

Contents

Model

- 50DSHU6.4
- 50DSHU6.75
- 50DSHU61.5
- 50DSU62.2
- 50DSHU62.2
- 50DSU63.7
- 50DSHU63.7
- 80DSU62.2
- 80DSHU62.2
- 80DSU63.7
- 80DSHU63.7
- 100DSU65.5
- 100DSU67.5

Section	Page
Specifications	1-157, 158
Selection Chart	1-157.1, 158.1
Performance Curves	1-161
Outline Drawings	1-166
Sectional View	1-169
QDC Information	1-189
Technical Information	1-195
material specification	
impeller description	
motor protection	
cable entry	
paint specifications	
mechanical seal	
general	
Motor Data	1-212.1
motor electrical specifications	
cable data	
wiring diagrams	
motor electrical data	



Model Designation

100 DS U 6 1.5 [] 2

DISCHARGE SIZE – mm

- 50mm – 2"
- 80mm – 3"
- 100mm – 4"

MODEL TYPE

- DS – submersible sump pump
- DSH – submersible sump pump, hot water model

GEOGRAPHIC DESIGNATION

- U – U.S.A. market

HERTZ

- 6-60

RATED KW

- .4 1/2HP
- .75 1HP
- 1.5 2HP
- 2.2 3HP
- 3.7 5HP
- 5.5 7 1/2HP
- 7.5 10HP

PHASE

- none – three phase

VOLTAGE

- 2 - 208/230
- 4 - 460

Specifications and Selection chart

**Model DSU
Specifications**

	Standard	Optional
Size	2, 3, 4 inch	
Range of HP Range of Performance	3 HP to 10 HP Capacity 8 to 390 GPM Head 10 to 126 feet	
Limitation Maximum Water Temperature	122 F (50 C)	
Synchronous Speed	3600 RPM	
Materials Casing Impeller Shaft Motor Frame Fastener	Cast Iron Ductile Iron 403 Stainless Steel Cast Iron 304 Stainless Steel	
Mechanical Seal Material – Upper Side Material – Lower Side Impeller Type Bearing Motor Three Phase Service Factor Motor Protection Submersible Cable Accessories	Double Mechanical Seal Carbon/Ceramic Silicon Carbide/Silicon Carbide Open Prelubricated Ball Bearing Air-filled, Insulation Class F 208/230/460V 1.15 Built-in Auto Cut - overload, out of phase, single phasing protection 33 ft. standard cable length Cast iron discharge elbow (3 to 5 HP)	66 ft. QDC System



Selection Chart

Model DSU

Three Phase

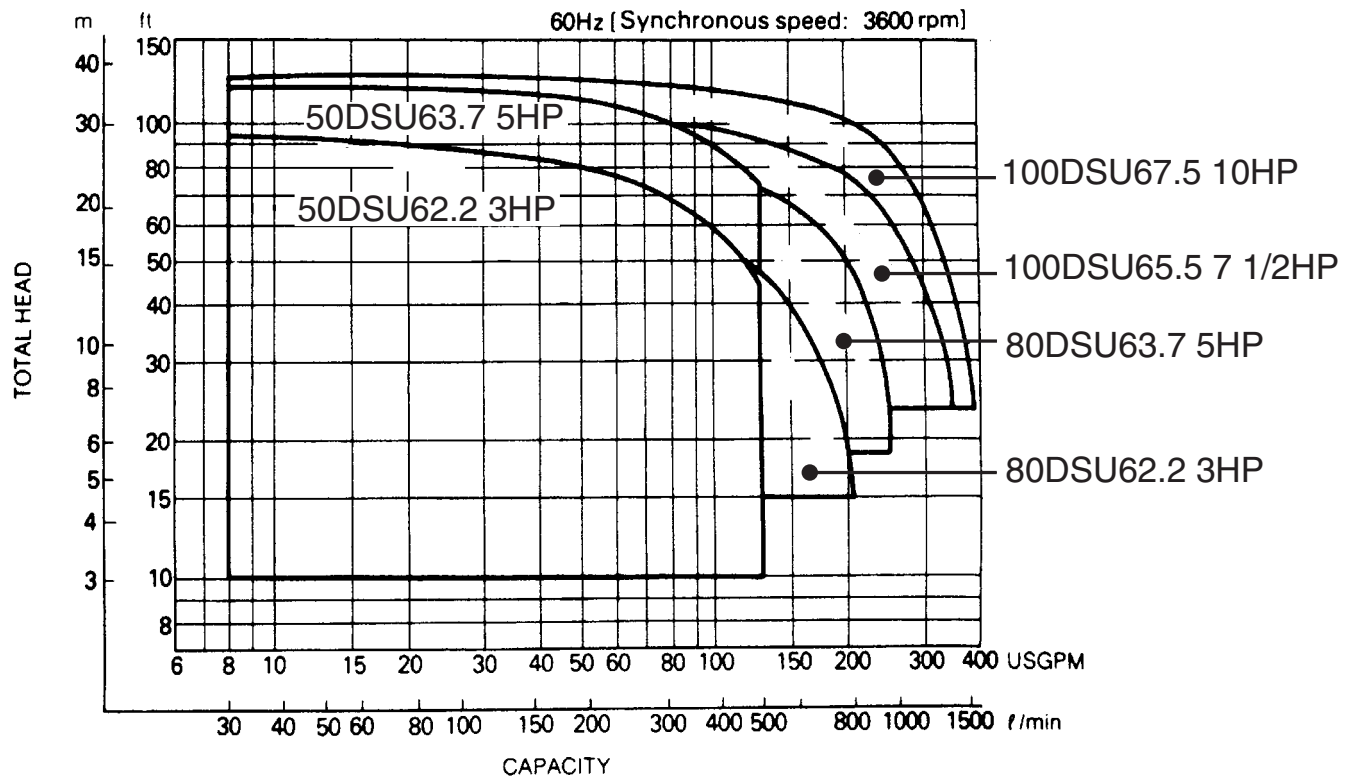

Specifications

Model DSHU – Hot Water Pumps Specifications

	Standard	Optional
Size	2, 3 inch	
Range of HP Range of Performance	1/2 HP to 5 HP Capacity 8 to 250 GPM Head 8 to 126 feet	
Limitation Maximum Water Temperature	158 F (70 C) 1/2 HP, 1 HP 176 F (80 C) 2 HP to 5 HP 200 F (93 C) Operation is limited to 10 minutes	
Synchronous Speed	3600 RPM	
Materials Casing Impeller Shaft Motor Frame Fastener	Cast Iron Cast Iron (1/2 to 2 HP), Ductile Iron (3, 5 HP) 403 Stainless Steel Cast Iron 304 Stainless Steel	
Mechanical Seal Material – Upper Side Material – Lower Side Impeller Type Bearing Motor Three Phase Service Factor Motor Protection Submersible Cable Accessories	Double Mechanical Seal Silicon Carbide/Silicon Carbide Silicon Carbide/Silicon Carbide Open Prelubricated Ball Bearing Air-filled, Insulation Class H (1/2, 1HP) Class F (2, 3, 5 HP) 208/230V, 460V - Single voltage 1.15 Built-in Overload Protection 33 ft. standard cable length Cast iron companion flange with NPT thread (1/2 to 2HP) Cast iron discharge elbow (3 to 5 HP)	66 ft. QDC System



Selection chart

Model DSHU – Hot Water Pumps
Three Phase

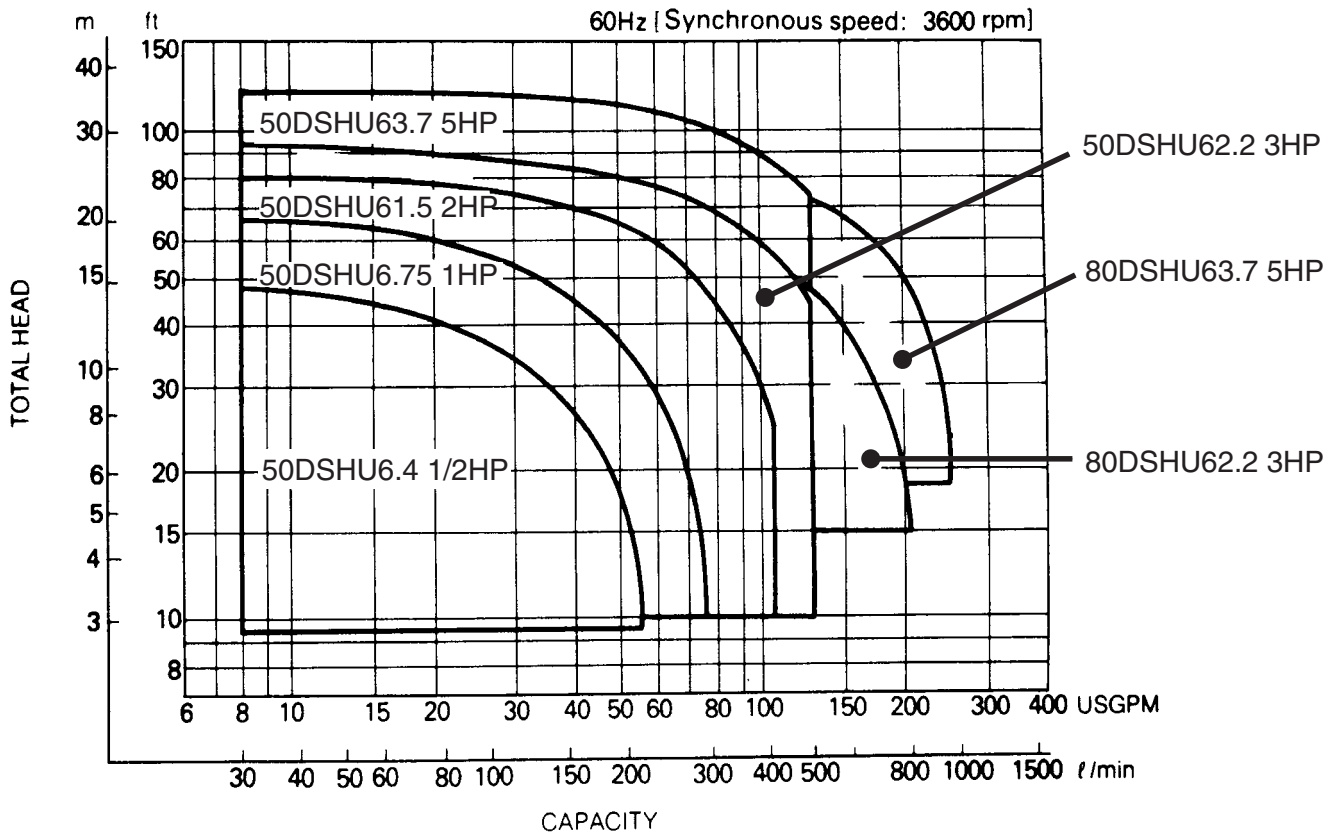

Specifications

A. General:

Provide submersible dewatering pumps suitable for continuous duty operation underwater without loss of watertight integrity to a depth of 65 feet. If mounted on a guide rail system, design shall be such that the pump will be automatically connected to the discharge piping when lowered into place on the discharge connection. The pump shall be easily removable for inspection or service, requiring no bolts, nuts, or other fasteners to be disconnected, or the need for personnel to enter the wet well. The motor and pump shall be designed, manufactured, and assembled by the same manufacturer.

B. Manufacturer:

Ebara International Corporation

C. Pump Characteristics:

Pumps shall conform to the following requirements:

Number of units	
Design flow (gpm)	
Design TDH (ft)	
Minimum shut off head (ft)	
RPM	3600
Maximum HP	
Minimum efficiency at design (%)	
Minimum power factor at design (%)	
Voltage/HZ	208/230V, 460V / 60
Phase	3

D. Pump Construction:

All major parts of the pumping unit(s) including casing, impeller, motor frame and discharge elbow shall be manufactured from gray cast iron, ASTM A-48 Class 30. Castings shall have smooth surfaces devoid of blow holes or other casting irregularities. Casing design shall be centerline discharge with a large radius on the cut water to prevent clogging. Units up to and including 2HP with 1½" and 2" discharge sizes shall be furnished with a female NPT connection. Units 3HP and above with 2" and larger discharge ports shall be furnished with a discharge elbow and 125 lb. flat face ANSI flange. All exposed bolts and nuts shall be 304 stainless steel. All mating surfaces of major components shall be machined and fitted with NBR O-rings where watertight sealing is required. Machining and fitting shall be such that sealing is accomplished by automatic compression of O-rings in two planes and O-ring contact is made on four surfaces without the requirement of specific torque limits. Units shall be provided with a galvanized strainer to prevent solids larger than the design will allow from entering the pump. Internal and external surfaces are prepared to SSPC-VIS1-3-63 then coated with a zinc-rich epoxy primer. The external surfaces are then coated with an H.B. Tneme-Tar 46-413 coal tar epoxy.

Impeller shall be multi-vane open design, direct connected to the motor shaft with a slip fit, key driven, and secured with an impeller nut. Units ½ to 2 HP shall be furnished with a replaceable 304SS wear plate. Units 3 HP and larger shall have impellers with back pump out vanes and rear shroud operating with a replaceable 304SS wear ring as well as a replaceable cast iron suction cover. Suction covers on all models shall be designed such that they may be adjusted to maintain working clearances and hydraulic efficiencies.

Double mechanical seals operating in an oil bath shall be provided on all units. The oil filled seal chamber shall be designed to prevent over-filling and include an anti-vortexing vane to insure proper lubrication of both seal faces. For applications under 122 F; lower face materials shall be silicon carbide, upper faces carbon vs ceramic, NBR elastomers, and 304SS hardware. Applications greater than 122 F shall include silicon carbide face materials for both upper and

Specifications

E. Motor Construction:

The pump motor shall be an air filled induction type with a squirrel cage rotor, shell type design, built to NEMA MG-1, Design B specifications. Stator windings shall be copper, insulated with moisture resistant Class F (Class H for DSU 1/2 & 1 HP models) insulation, rated for 311 F. The stator shall be dipped and baked three times in Class F varnish and heat shrunk fitted into the stator housing. Rotor bars and short circuit rings shall be manufactured of cast aluminum. Motor shaft shall be one piece 403SS AISI403 material, rotating on two permanently lubricated ball bearings designed for a minimum B-10 life of 60,000 hours. Model DSU motors shall be designed for continuous duty pumping at a maximum sump temperature of 122 F and capable of up to 20 starts per hour. Model DSHU motors shall be designed for up to 20 starts per hour continuous duty pumping at a maximum sump temperature of 158 F for 1/2 and 1 HP units, and 176 F for 2 to 5 HP units. Motor service factor shall be 1.15. Voltage and frequency tolerances shall be a maximum 10%/5% respectively. Junction area shall include a terminal board for power connections eliminating the need for wire nuts. Motor protection shall be provided by an auto-cut device located directly over the windings to provide protection from single phasing, low voltage, phase imbalance, locked rotor, and no load or run dry conditions. Motor shall be non-overloading over the entire performance curve and be able to operate at full load intermittently while unsubmerged without damage to the unit.

Power cable jacket shall be manufactured of an oil resistant chloroprene rubber material, designed for submerged applications. Cable shall be watertight to a depth of at least 65'. Cable entry shall be composed of a one piece, vulcanized, three way mechanical sealing system with a thick molded shoulder with increasing cable diameters to resist fatigue from bending forces. The molded shoulder, acts as the primary and secondary sealing points. This system shall also prevent leakage into the motor housing due to capillary action through the insulation if the cable is damaged or cut. Units 1/2 to 7 1/2 HP shall utilize a metallic plate to clamp the entry system to the motor housing. Strain relief on these sizes shall be accomplished by clamping and attaching the cable with chain to the motor housing. Units larger than 7 1/2 HP shall utilize a cast iron cable housing which is bolted to the top of the motor housing causing a compression fit between the molded shoulder and the top of the motor. Strain relief protection shall be provided by clamping the cable to the cable housing.

F. Guide Rail system:

Design shall include two (2) 304SS schedule 40 guide rails sized to mount directly to the quick discharge connector, QDC, at the floor of the wetwell and to a guide rail bracket at the top of the wetwell below the hatch opening, (refer to project drawings).

Units below one (1) HP shall utilize a single angle iron rail in lieu of two (2) Guide pipes. Intermediate guide brackets shall be supplied for rail lengths over 20 feet.

Guide rails are not part of the pump package and shall be supplied by others.

The QDC shall be manufactured of cast iron, A48 Class 30. It shall be designed to adequately support the guide rails, discharge piping, and pumping unit under both static and dynamic loading conditions with support legs that are suitable for anchoring it to the wetwell floor. The face of the inlet QDC flange shall be perpendicular to the floor of the wetwell.

The pump design shall include an integral self-aligning sliding bracket. Sealing of the pumping unit to the QDC shall be accomplished by a single, linear, downward motion of the pump. The entire weight of the pump unit shall be guided to and wedged tightly against the inlet flange of the QDC, making metal to metal contact with the pump discharge forming a seal without the use of bolts, gaskets or O-rings.

Lifting chain, either galvanized or stainless steel, suitable for removing and installing the pump unit shall be provided.



Performance Curves

Project: _____ GPM: _____ TDH: _____ EFF: _____ HP: _____ Chk'd: _____ Date: _____

50DSH6.4 (1/2HP) Synchronous Speed: 3600 RPM

2 inch Discharge

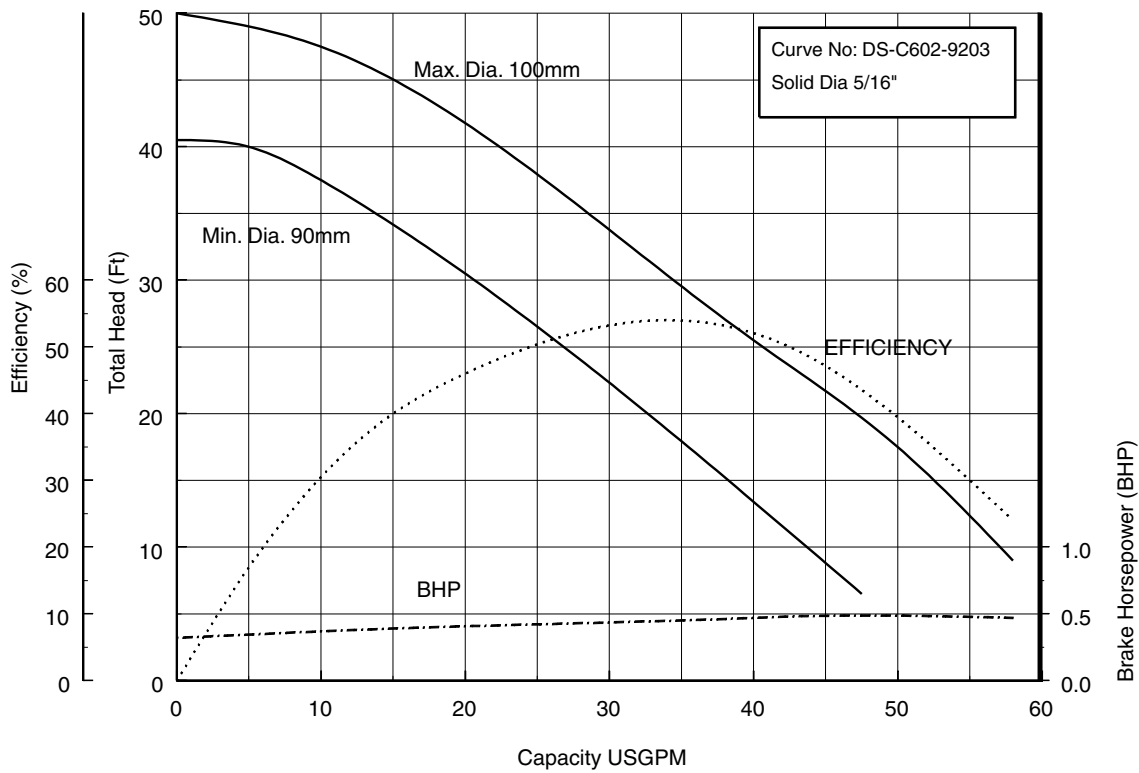

50DSH6.75 (1HP) Synchronous Speed: 3600 RPM

2 inch Discharge

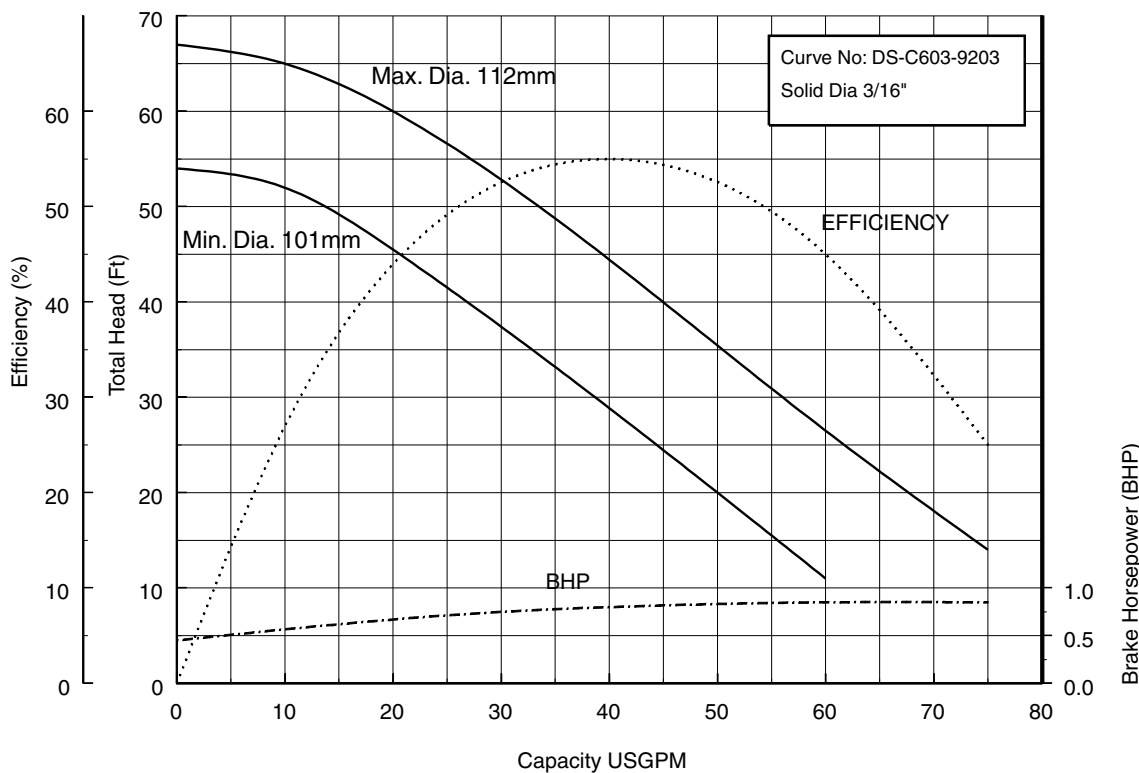

Performance Curves

Project: _____ GPM: _____ TDH: _____ EFF: _____ HP: _____ Chk'd: _____ Date: _____

50DSH61.5 (2HP) Synchronous Speed: 3600 RPM

2 inch Discharge

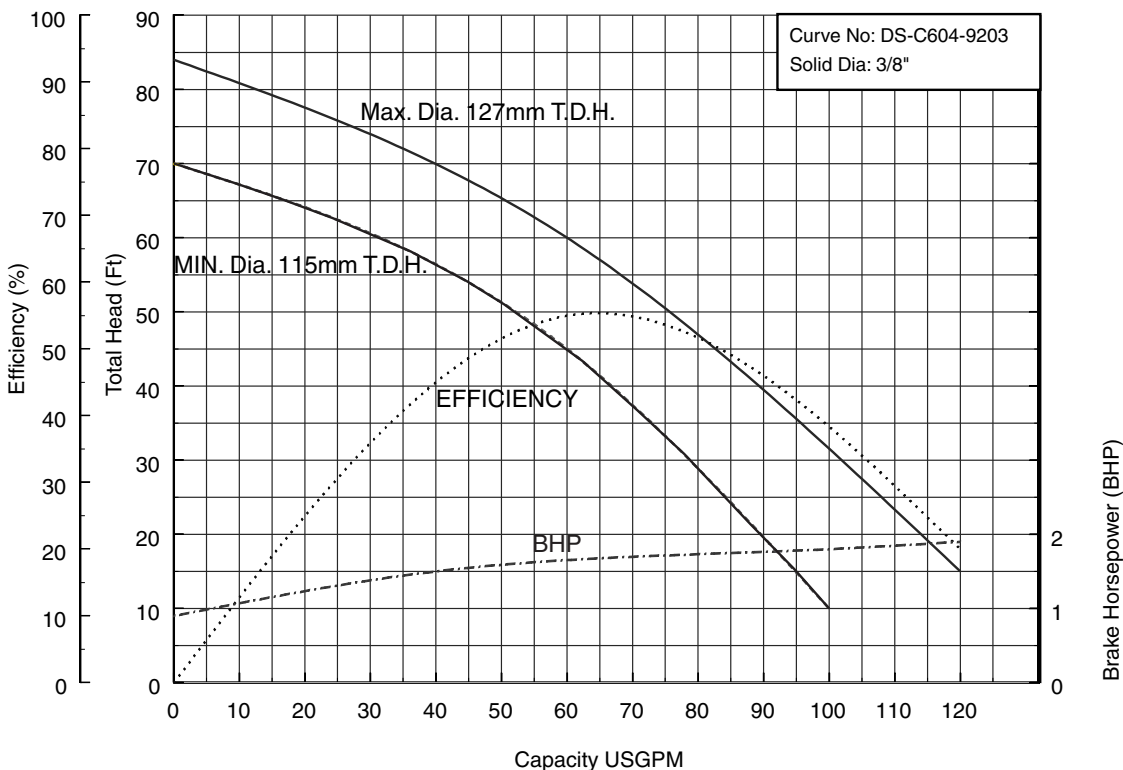

50DS62.2 50DSH62.2 (3HP) Synchronous Speed: 3600 RPM

2 inch Discharge

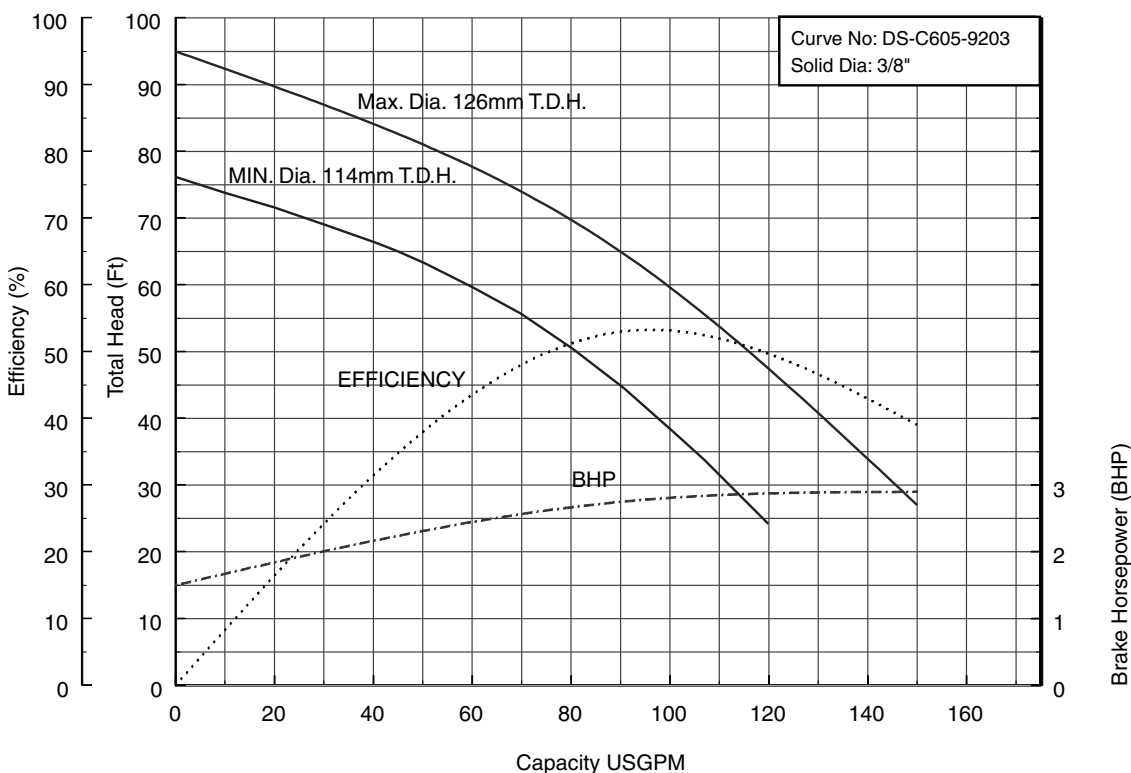

Performance Curves

Project: _____ GPM: _____ TDH: _____ EFF: _____ HP: _____ Chk'd: _____ Date: _____

50DS63.7 50DSH63.7 (5HP) Synchronous Speed: 3600 RPM

2 inch Discharge

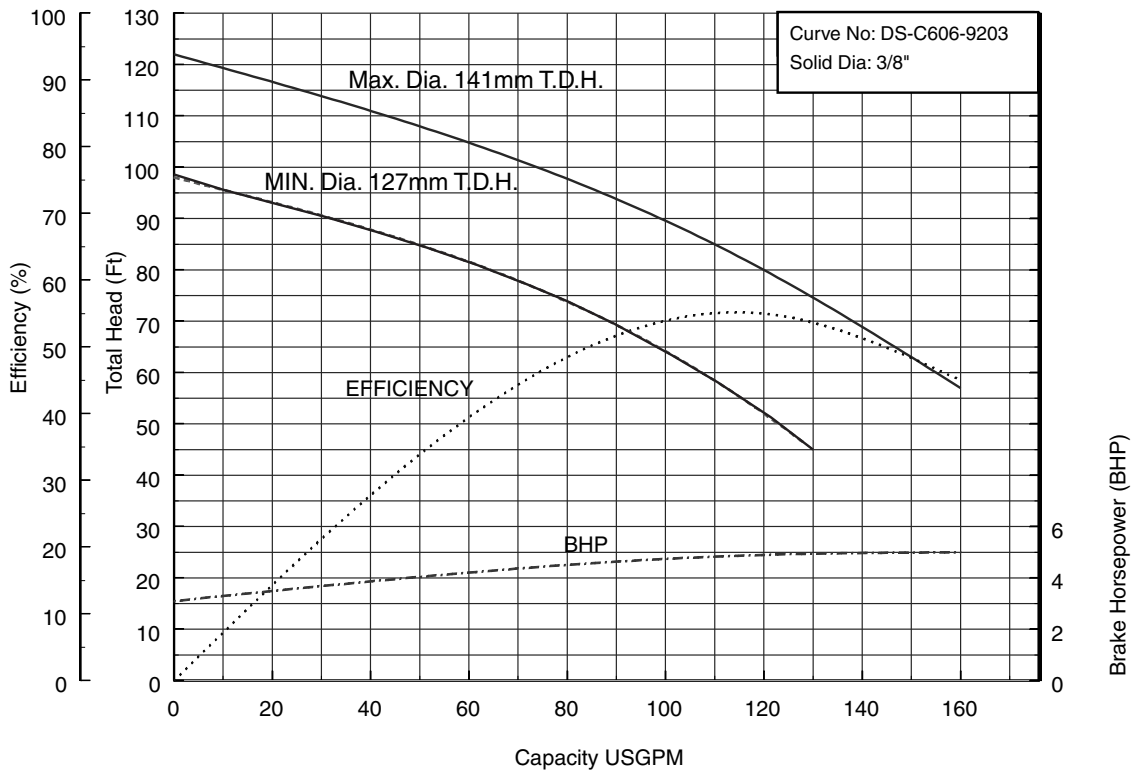

80DS62.2 80DSH62.2 (3HP) Synchronous Speed: 3600 RPM

3 inch Discharge

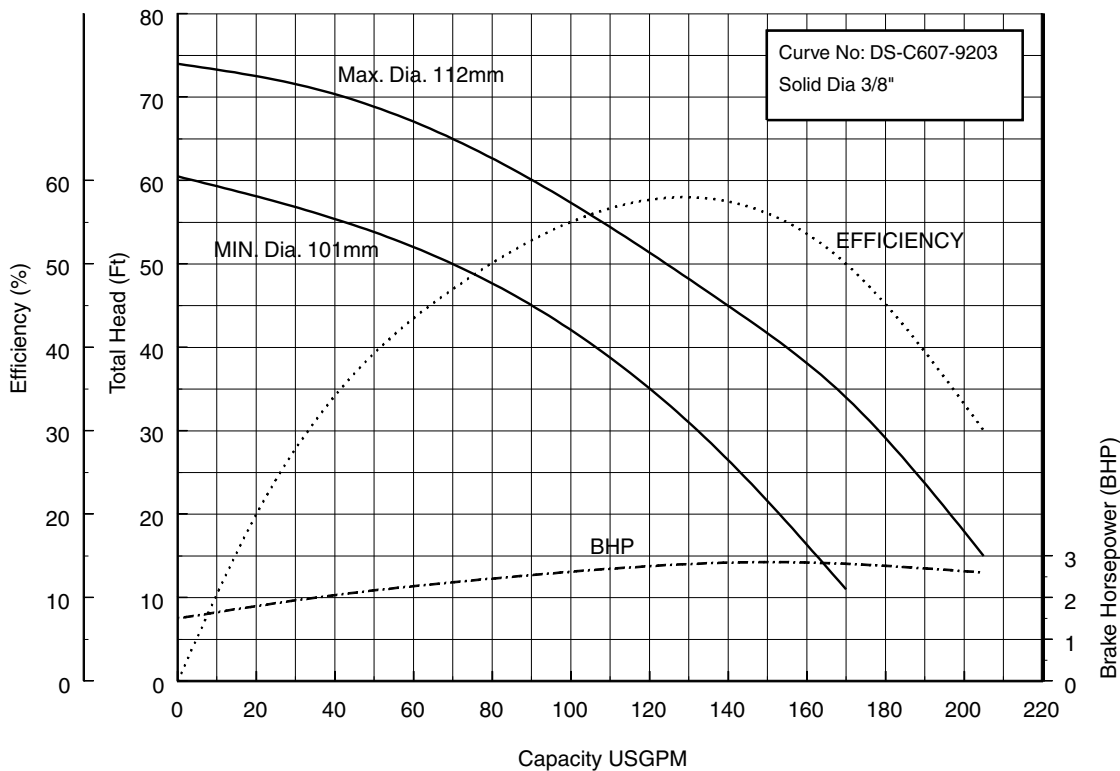

Performance Curves

Project: _____ GPM: _____ TDH: _____ EFF: _____ HP: _____ Chk'd: _____ Date: _____

80DS63.7 80DSH63.7 (5HP) Synchronous Speed: 3600 RPM

3 inch Discharge

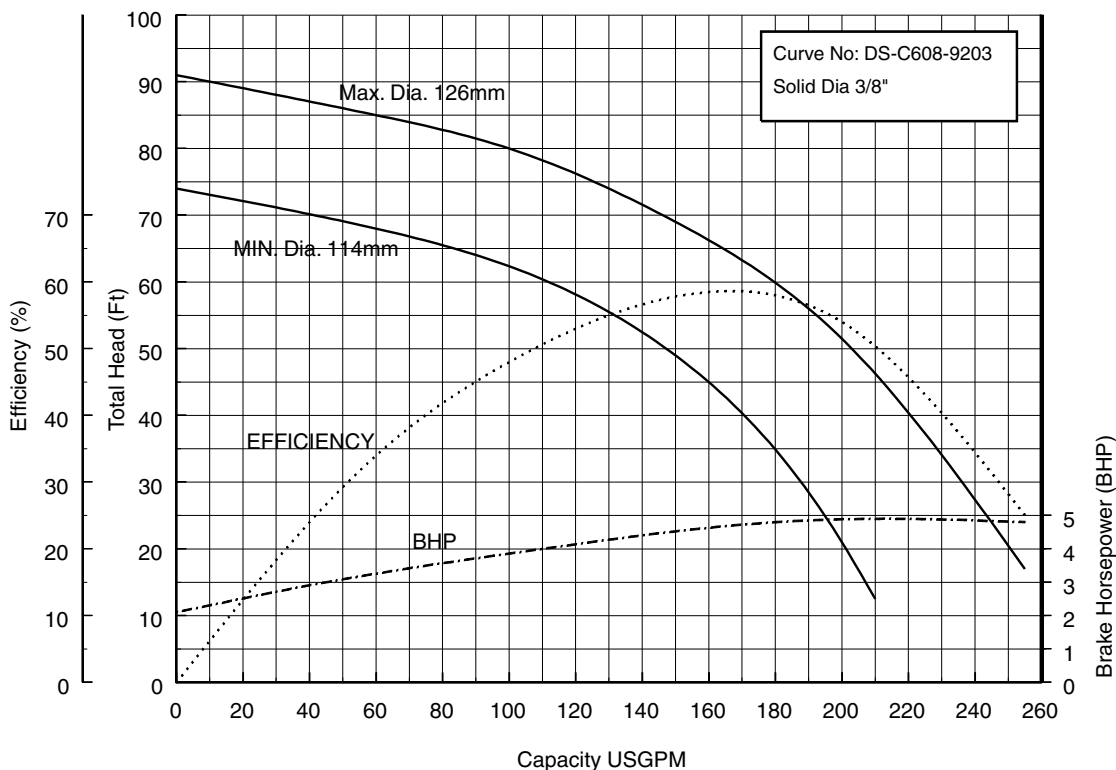

100DS65.5 (7½HP) Synchronous Speed: 3600 RPM

4 inch Discharge

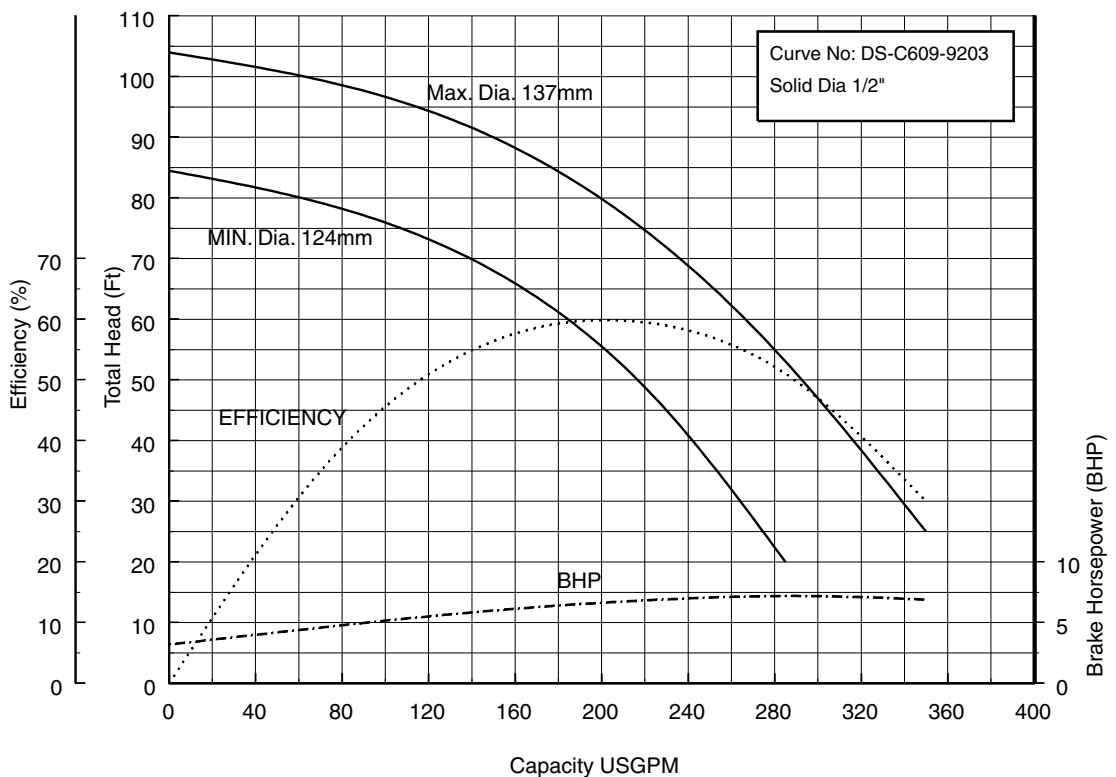

Performance Curves

Project: _____ GPM: _____ TDH: _____ EFF: _____ HP: _____ Chk'd: _____ Date: _____

100DS67.5 (10HP) Synchronous Speed: 3600 RPM

4 inch Discharge

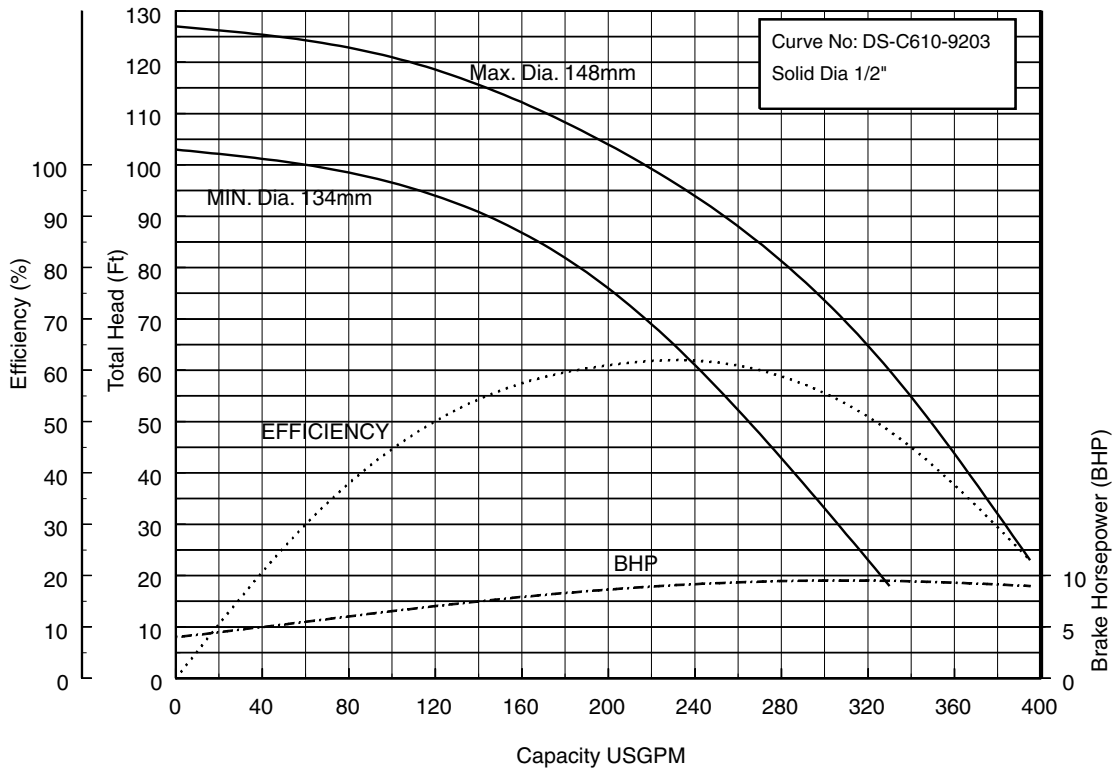

Dimensions

Project: _____ Model: _____ Chk'd: _____ Date: _____

Model DSHU
 Hot Water Pumps
 50DSHU, 1/2 to 2HP

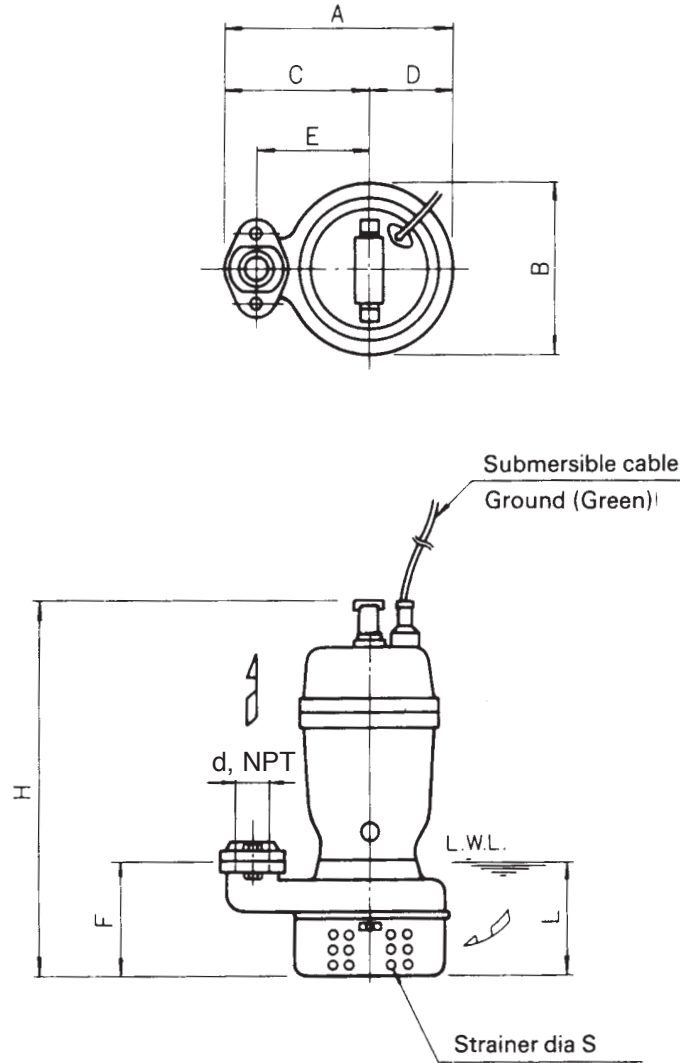

Dimensions: inch

PHASE	SIZE _d	MODEL	OUTPUT		PUMP & MOTOR									WEIGHT Lb
			kW	HP	A	B	C	D	E	F	H	L	S	
THREE	2	50DSHU6.4	0.4	1/2	10 ¹ / ₄	7 ³ / ₁₆	6 ⁵ / ₈	3 ³ / ₈	5 ¹ / ₈	3 ⁷ / ₈	15 ⁹ / ₁₆	4 ³ / ₁₆	5 ¹ / ₁₆	35
		50DSHU6.75	0.75	1	10 ¹ / ₄	7 ⁵ / ₁₆	6 ⁵ / ₈	3 ⁵ / ₈	5 ¹ / ₈	3 ⁷ / ₈	15 ⁹ / ₁₆	4 ⁵ / ₁₆	5 ¹ / ₁₆	37
		50DSHU61.5	1.5	2	10 ¹ / ₂	7 ¹ / ₈	6 ⁵ / ₈	3 ⁷ / ₈	5 ¹ / ₈	4 ¹ / ₂	17 ¹¹ / ₁₆	4 ³ / ₄	3 ³ / ₈	57

Dimensions: mm

PHASE	SIZE _d	MODEL	OUTPUT		PUMP & MOTOR									WEIGHT kg
			kW	HP	A	B	C	D	E	F	H	L	S	
THREE	50	50DSHU6.4	0.4	1/2	260	186	168	92	130	99	396	110	8	16
		50DSHU6.75	0.75	1	260	186	168	92	130	99	396	110	8	17
		50DSHU61.5	1.5	2	266	200	168	98	130	115	450	120	10	26

Dimensions

Project: _____ Model: _____ Chk'd: _____ Date: _____

Model DSHU
 Hot Water Pumps
 50DSHU, 3 to 5 HP
 80DSHU, 3 to 5 HP

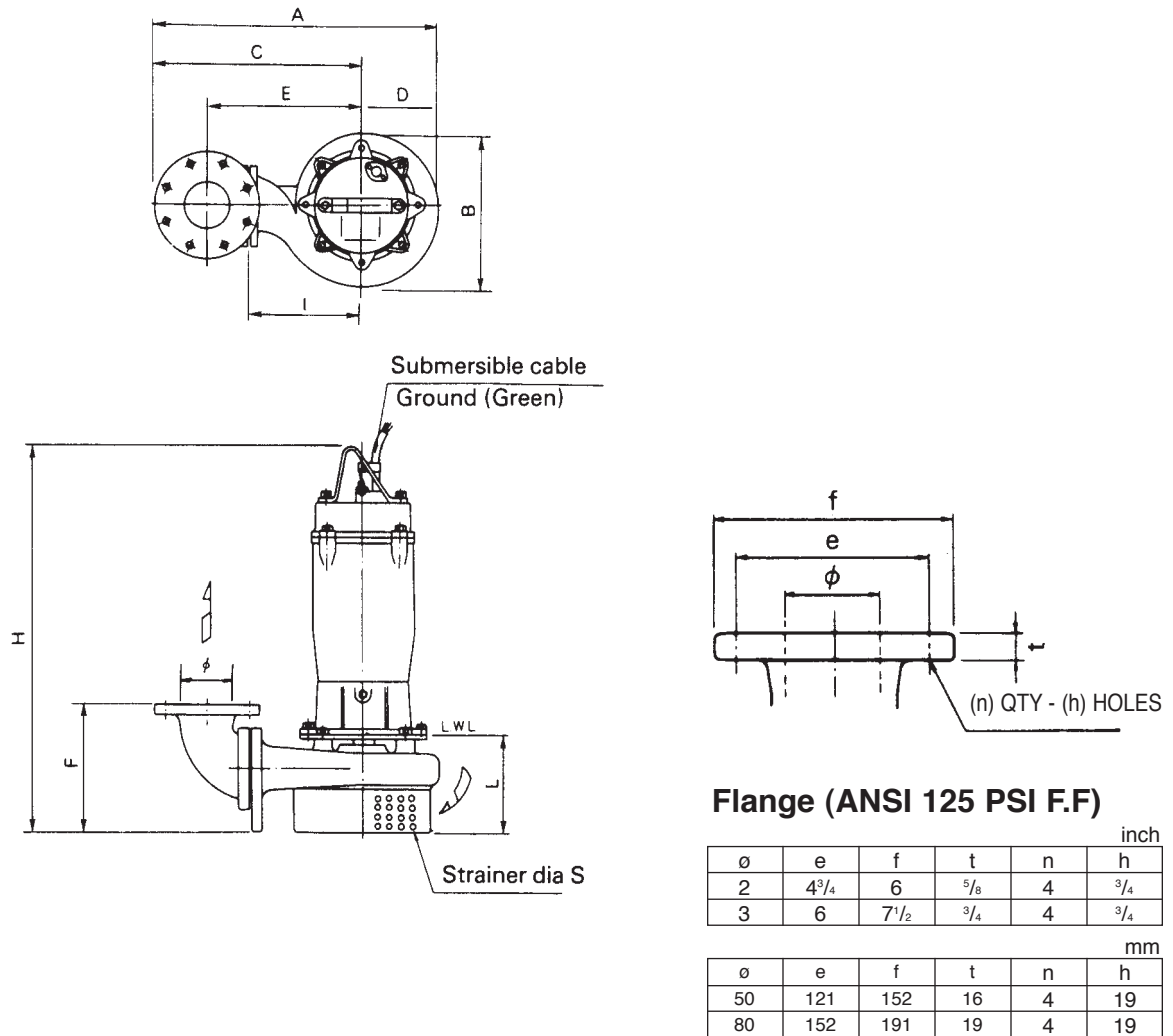

Flange (ANSI 125 PSI F.F)

inch					
ø	e	f	t	n	h
2	4 ³ / ₄	6	5 ⁵ / ₈	4	3 ³ / ₄
3	6	7 ¹ / ₂	3 ³ / ₄	4	3 ³ / ₄

mm					
ø	e	f	t	n	h
50	121	152	16	4	19
80	152	191	19	4	19

Dimensions: inch

PHASE	SIZE ø	MODEL	OUTPUT		PUMP & MOTOR										WEIGHT Lb
			kW	HP	A	B	C	D	E	F	H	I	L	S	
THREE	2	50DSHU62.2	2.2	3	17 ¹ / ₁₆	9 ⁵ / ₈	12 ⁵ / ₁₆	4 ³ / ₄	9 ¹ / ₄	7 ¹³ / ₁₆	24 ¹⁵ / ₁₆	7 ¹ / ₁₆	6 ⁵ / ₁₆	3 ³ / ₈	119
		50DSHU63.7	3.7	5	17 ¹ / ₁₆	9 ⁵ / ₈	12 ⁵ / ₁₆	4 ³ / ₄	9 ¹ / ₄	7 ¹³ / ₁₆	26 ¹ / ₄	7 ¹ / ₁₆	6 ⁵ / ₁₆	3 ³ / ₈	134
	3	80DSHU62.2	2.2	3	19 ⁹ / ₁₆	10 ⁹ / ₁₆	14 ¹ / ₂	5 ⁵ / ₁₆	10 ¹³ / ₁₆	8 ⁷ / ₁₆	25 ³ / ₁₆	7 ⁷ / ₈	6 ⁵ / ₁₆	3 ³ / ₈	128
		80DSHU63.7	3.7	5	19 ⁹ / ₁₆	10 ⁹ / ₁₆	14 ¹ / ₂	5 ⁵ / ₁₆	10 ¹³ / ₁₆	8 ⁷ / ₁₆	26 ¹ / ₂	7 ⁷ / ₈	6 ⁵ / ₁₆	3 ³ / ₈	141

Dimensions: mm

PHASE	SIZE ø	MODEL	OUTPUT		PUMP & MOTOR										WEIGHT kg
			kW	HP	A	B	C	D	E	F	H	I	L	S	
THREE	50	50DSHU62.2	2.2	3	433	245	313	120	235	198	634	180	160	10	54
		50DSHU63.7	3.7	5	433	245	313	120	235	198	667	180	160	10	61
	80	80DSHU62.2	2.2	3	503	268	368	135	275	215	640	200	160	10	58
		80DSHU63.7	3.7	5	503	268	368	135	275	215	673	200	160	10	64

Dimensions

Project: _____ Model: _____ Chk'd: _____ Date: _____

Model DSU

50DSU, 3 to 5 HP
 80DSHU, 3 to 5 HP
 100DSU, 7½ to 10 HP

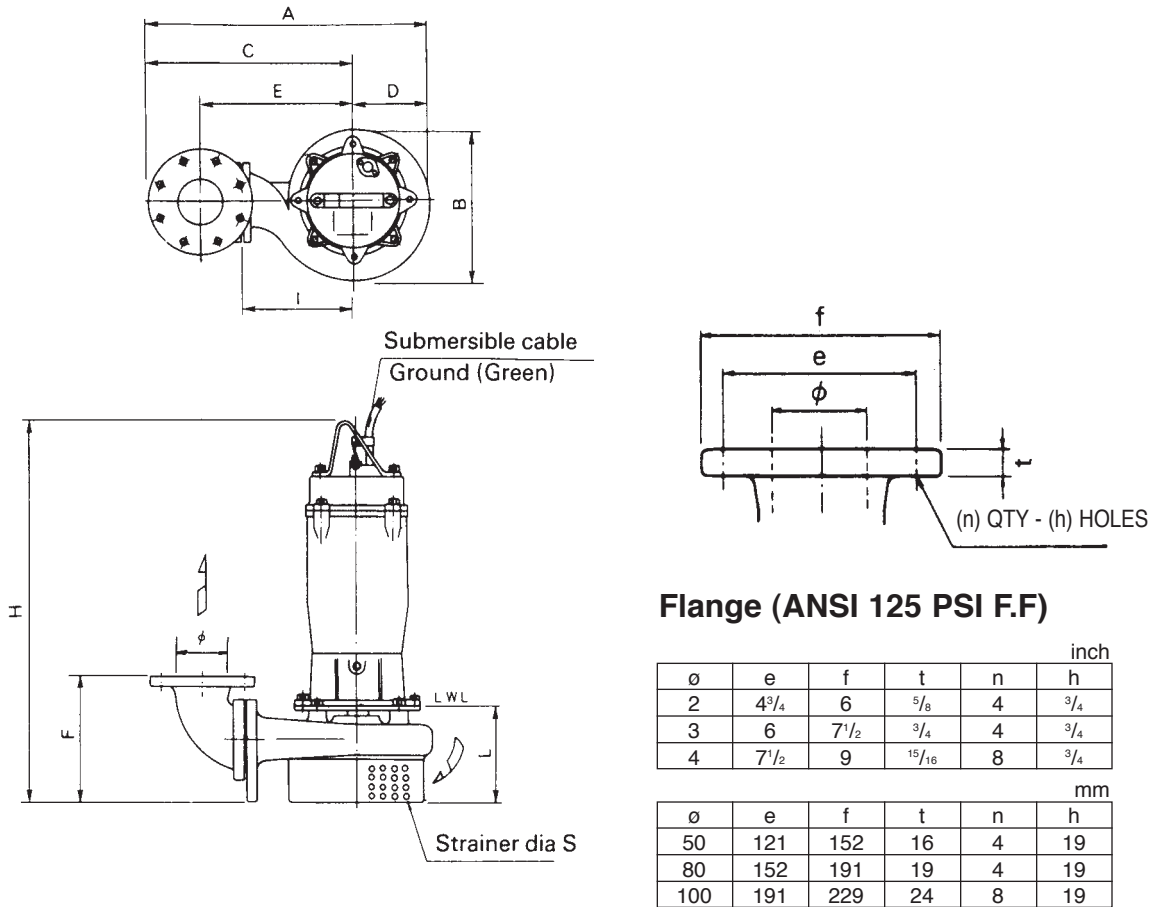

Flange (ANSI 125 PSI F.F)

inch					
ø	e	f	t	n	h
2	4¾	6	5/8	4	¾
3	6	7½	¾	4	¾
4	7½	9	15/16	8	¾

mm					
ø	e	f	t	n	h
50	121	152	16	4	19
80	152	191	19	4	19
100	191	229	24	8	19

Dimensions: inch

PHASE	SIZE ø	MODEL	OUTPUT		PUMP & MOTOR										WEIGHT Lb
			kW	HP	A	B	C	D	E	F	H	I	L	S	
THREE	2	50DSU62.2	2.2	3	17 ¹ / ₁₆	9 ⁵ / ₈	12 ⁵ / ₁₆	4 ³ / ₄	9 ¹ / ₄	7 ¹³ / ₁₆	27 ¹¹ / ₁₆	7 ¹ / ₁₆	6 ⁵ / ₁₆	¾	119
		50DSU63.7	3.7	5	17 ¹ / ₁₆	9 ⁵ / ₈	12 ⁵ / ₁₆	4 ³ / ₄	9 ¹ / ₄	7 ¹³ / ₁₆	27 ¹¹ / ₁₆	7 ¹ / ₁₆	6 ⁵ / ₁₆	¾	130
	3	80DSU62.2	2.2	3	19 ¹³ / ₁₆	10 ⁹ / ₁₆	14 ¹ / ₂	5 ⁵ / ₁₆	10 ¹³ / ₁₆	8 ⁷ / ₁₆	27 ¹⁵ / ₁₆	7 ⁷ / ₈	6 ⁵ / ₁₆	¾	128
		80DSU63.7	3.7	5	19 ¹³ / ₁₆	10 ⁹ / ₁₆	14 ¹ / ₂	5 ⁵ / ₁₆	10 ¹³ / ₁₆	8 ⁷ / ₁₆	27 ¹⁵ / ₁₆	7 ⁷ / ₈	6 ⁵ / ₁₆	¾	137
	4	100DSU65.5	5.5	7½	24 ³ / ₁₆	12 ² / ₁₆	18 ¹ / ₈	6 ¹ / ₈	14	10 ¹ / ₈	30 ⁵ / ₈	9 ¹³ / ₁₆	7 ⁷ / ₈	½	194
		100DSU67.5	7.5	10	24 ³ / ₁₆	12 ² / ₁₆	18 ¹ / ₈	6 ¹ / ₈	14	10 ¹ / ₈	30 ⁵ / ₈	9 ¹³ / ₁₆	7 ⁷ / ₈	½	203

Dimensions: mm

PHASE	SIZE ø	MODEL	OUTPUT		PUMP & MOTOR										WEIGHT kg
			kW	HP	A	B	C	D	E	F	H	I	L	S	
THREE	50	50DSU62.2	2.2	3	433	245	313	120	235	198	703	180	160	10	54
		50DSU63.7	3.7	5	433	245	313	120	235	198	703	180	160	10	59
	80	80DSU62.2	2.2	3	503	268	368	135	275	215	709	200	160	10	58
		80DSU63.7	3.7	5	503	268	368	135	275	215	709	200	160	10	62
	100	100DSU65.5	5.5	7½	615	309	460	155	355	257	778	250	200	13	88
		100DSU67.5	7.5	10	615	309	460	155	355	257	778	250	200	13	92

Sectional View

Project: _____ Model: _____ Chk'd: _____ Date: _____

Model DSHU
Hot Water Pumps
1/2 to 2HP

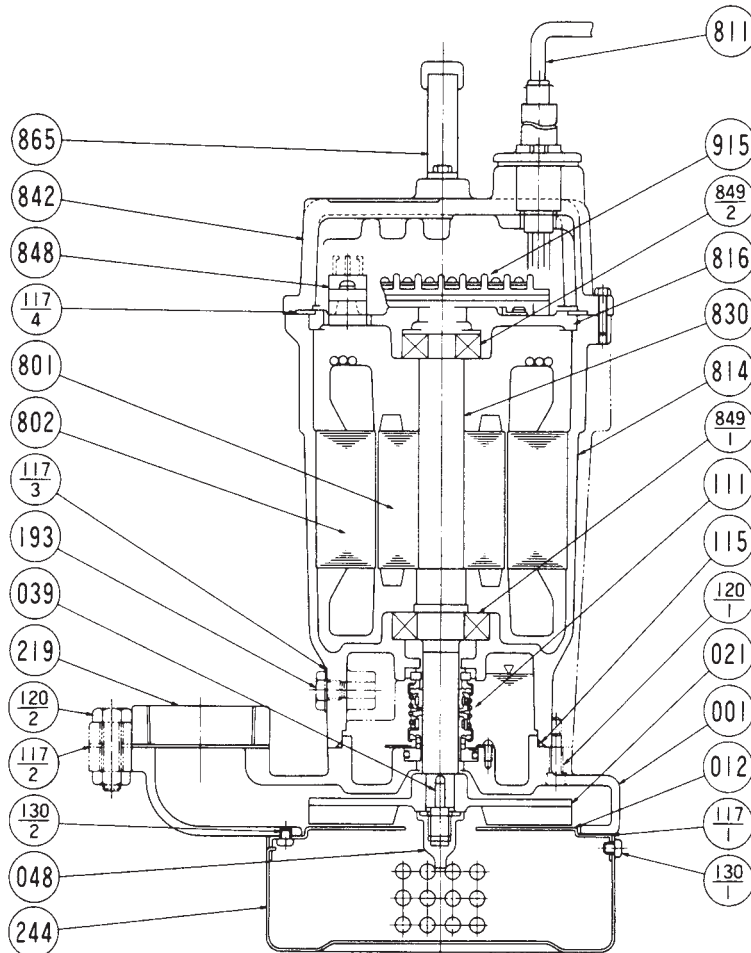

Motors purchased as a complete unit.

PART NO.	PART NAME	MATERIAL	ASTM, AISI CODE	NO. FOR 1 UNIT	PART NO.	PART NAME	MATERIAL	ASTM, AISI CODE	NO. FOR 1 UNIT
001	CASING	CAST IRON	A48 Class 30	1	193	OIL PLUG	BRASS	B36 No. 272	1
012	SUCTION COVER	304 STAINLESS	AISI304	1	219	COMPANION FLANGE	CAST IRON	A48 Class 30	1
†021	IMPELLER	CAST IRON	A48 Class 30	1	244	STRAINER	STEEL	A283 Grade D	1
039	KEY	420 STAINLESS	AISI420	1	801	ROTOR	—		1
048	IMPELLER NUT	BRASS	B36 No. 272	1	802	STATOR	—		1
†111	MECHANICAL SEAL	—		1 SET	†811	SUBMERSIBLE CABLE	—		1
†115	O-RING	RUBBER (NBR)		1	814	MOTOR FRAME	CAST IRON	A48 Class 30	1
†117-1	GASKET	PRESS BOARD		1	816	BRACKET	CAST IRON	A48 Class 30	1
†117-2	GASKET	RUBBER (CR or NBR)		1	830	SHAFT	403 STAINLESS	AISI403	1
†117-3	GASKET			1	842	MOTOR COVER	CAST IRON	A48 Class 30	1
†117-4	GASKET (MODEL DSU)	RUBBER (NBR)		1	848	MOTOR PROTECTOR	—		1
	O-RING (MODEL DSHU)	RUBBER (NBR)		1	†849-1	BALL BEARING	—		1
120-1	BOLT	304 STAINLESS	AISI304	3 or 4	† 849-2	BALL BEARING	—		1
120-2	BOLTS	304 STAINLESS	AISI304	2	865	HANDLE	304 STAINLESS	AISI304	1
130-1	SCREW	304 STAINLESS	AISI304	1	915	EXTERNAL TERMINAL	—		1~2
130-2	SCREW	304 STAINLESS	AISI304	3 or 4					

†: Recommended spare parts.

Sectional View

Project: _____ Model: _____ Chk'd: _____ Date: _____

Model DSU

3 to 10HP

Model DSHU

Hot Water Pumps

3 to 5HP

3 to 5HP

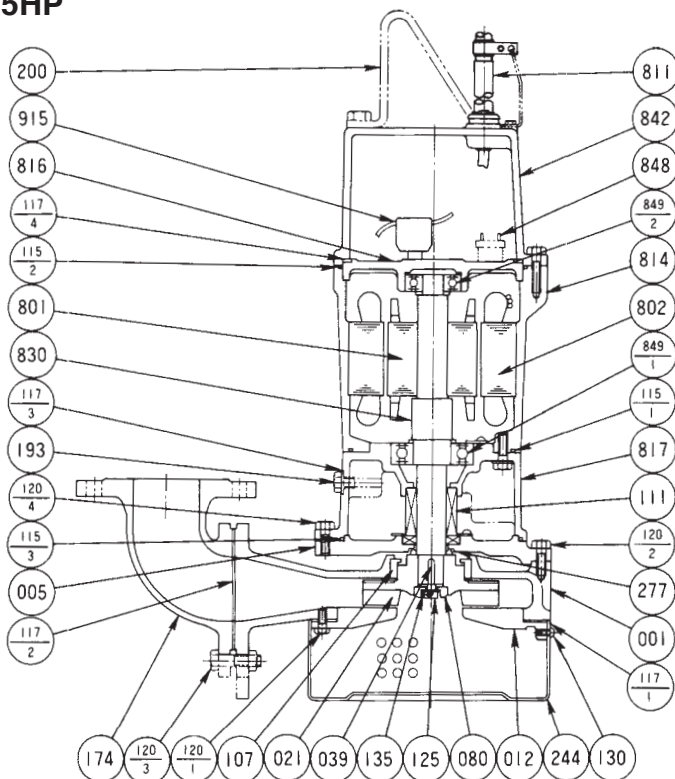

7 1/2, 10HP

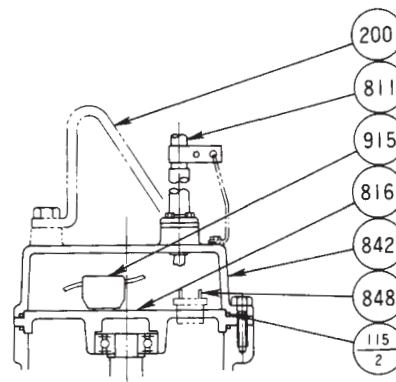

Motors purchased as a complete unit.
 Parts No. 915 is not installed for Model DSHU.
 Parts No. 117-4 is not installed, No. 115-2 is installed 2 pcs. for 7 1/2-10HP.

PART NO.	PART NAME	MATERIAL	ASTM, AISI CODE	NO. FOR 1 UNIT
001	CASING	CAST IRON	A48 Class 30	1
005	INTERMEDIATE CASING	CAST IRON	A48 Class 30	1
012	SUCTION COVER	CAST IRON	A48 Class 30	1
†021	IMPELLER	DUCTILE IRON	A536 GR60-40-18	1
039	KEY	420 STAINLESS	AISI420	1
080	BUSHING	STEEL	A283 Grade D	1
†107	WEARING RING	304 STAINLESS	AISI 304	1
†111	MECHANICAL SEAL	—	—	1 SET
†115-1	O-RING	RUBBER (NBR)	—	1
†115-2	O-RING	RUBBER (NBR)	—	1 or 2
†115-3	O-RING	RUBBER (NBR)	—	1
†117-1	GASKET	PRESS BOARD	—	1
†117-2	GASKET	—	—	1
†117-3	GASKET	—	—	1
†117-4	GASKET	RUBBER (NBR)	—	1
120-1	BOLT	304 STAINLESS	AISI304	4
120-2	BOLT	304 STAINLESS	AISI304	4
120-3	BOLT	304 STAINLESS	AISI304	4
120-4	BOLT	304 STAINLESS	AISI304	2
125	BOLT	304 STAINLESS	AISI304	1

PART NO.	PART NAME	MATERIAL	ASTM, AISI CODE	NO. FOR 1 UNIT
130	SCREW	304 STAINLESS	AISI304	2
135	WASHER	304 STAINLESS	AISI304	1
174	DISCHARGE ELBOW	CAST IRON	A48 Class 30	1
193	OIL PLUG	BRASS	B36 No. 272	1
200	LIFTING HANGER	STEEL	A283 Grade D	1
244	STRAINER	STEEL	A283 Grade D	1
277	"V" RING	RUBBER (NBR)	—	1
801	ROTOR	—	—	1
802	STATOR	—	—	1
†811	SUBMERSIBLE CABLE	—	—	1
814	MOTOR FRAME	CAST IRON	A48 Class 30	1
816	BRACKET	CAST IRON	A48 Class 30	1
817	BRACKET	CAST IRON	A48 Class 30	1
830	SHAFT	403 STAINLESS	AISI403	1
842	MOTOR COVER	CAST IRON	A48 Class 30	1
848	MOTOR PROTECTOR	—	—	1
†849-1	BALL BEARING	—	—	1
†849-2	BALL BEARING	—	—	1
915	EXTERNAL TERMINAL	—	—	1

†: Recommended spare parts.